



TS, TR

Master Parts Manual

Manual des pièces • Manual de Piezas Prototipo
Ersatzteilhandbuch • Cataloga Parti Principale

Introduction - English

The purpose of this Master Parts Manual is to give a record of the parts used on Lister-Petter TS and TR engines together with alterations and modifications that have been effected.

Main bearings and big end bearings are available undersize and pistons and rings are available oversize. Piston rings are only supplied as a complete set and pistons are supplied complete with rings, gudgeon pin and circlips.

Due to continued development and improvement it is quite possible that a part purchased may not completely resemble that illustrated. Not all items are illustrated and if an item is listed without a part number it is only available as part of an assembly. Although a part number may be shown, the item may not be available on its own but as an assembly. Items that are shown indented under an entry are included in, and form part of an assembly.

To help the user identify parts, most lists have an illustration with the individual parts given the same item number reference as appears in the list. Care should be taken to ensure the correct illustration is being referred to.

Replacement parts should be ordered by quoting the Part Number, not the illustration item number, and the engine serial number.

Each engine has a unique serial number which is stamped on a plate attached to the air cowling. It is necessary for this serial number to be identified before using this manual to ensure the part being requested is correct for the particular engine. Where the Build Number is preceded by a 9 this indicates that the engine is either of a non-standard configuration, or contains non-standard parts or accessories.

Engine Serial Number



Serial Number Code

43 Year of manufacture code
 00014 Consecutive number of engine
 TS2 Model
 A Anti-clockwise rotation
 001 Build

CAUTION

Parts that have not been approved for use on TS or TR engines cannot be relied upon for correct material, dimensions or finish.

Introduction - Français

Ce Manuel des pièces constitue un dossier présentant les pièces utilisées sur les moteurs TS et TR Lister-Petter ainsi que les changements et modifications qui ont été effectués.

Les paliers et les coussinets de bielle sont disponibles minorés et les pistons et les segments sont disponibles majorés. Les segments de piston ne sont fournis que sous forme de jeu complet et les pistons sont fournis dotés de segments, d'axe et de circlips.

En raison d'une politique de développement et d'amélioration permanents, il est tout à fait possible qu'une pièce achetée puisse ne pas entièrement ressembler à celle illustrée. Ce ne sont pas tous les articles qui sont illustrés et, si un article est listé sans numéro, il n'est disponible que comme partie d'un ensemble. Bien qu'un numéro puisse être indiqué, l'article peut ne pas être disponible tout seul, mais sous forme d'ensemble. Les articles qui sont mis en retrait sous une entrée sont inclus dans un ensemble et font partie de ce dernier.

Afin d'aider l'utilisateur à identifier les pièces, la plupart des listes comportent une illustration, les pièces individuelles étant affectées de la même référence que celle figurant sur la liste. Il faut veiller à se référer à la bonne illustration.

Les pièces de rechange devraient être commandées en indiquant le numéro de la pièce, et non le numéro de l'illustration, et le numéro d'ordre du moteur.

Chaque moteur comporte un numéro d'ordre unique qui est gravé sur une plaque attachée au capot. Il est nécessaire de vérifier ce numéro d'ordre avant d'utiliser ce manuel pour veiller à ce que la pièce demandée soit correcte pour le moteur particulier. Lorsque le numéro de construction est précédé d'un 9, cela indique que le moteur est d'une configuration non standard, ou contient des pièces ou accessoires non standards.

Plaque de numéro d'ordre



Code de numéro d'ordre

43 Code de l'année de fabrication
 00014 Numéro consécutif du moteur
 TS2 Modèle
 A Sens antihoraire
 001 Modèle du moteur

ATTENTION

On ne peut pas se fier aux matériaux, dimensions ou fini des pièces qui ne sont pas homologuées pour utilisation sur les moteurs TS ou TR.

Einleitung - Deutsch

In diesem Teilehauptbuch sollen die bei Lister-Petter Motoren TS und TR zur Anwendung kommenden Teile sowie die daran vorgenommenen Änderungen und Modifikationen aufgeführt werden.

Hauptlager und Pleuelfußlager können mit Untermaß geliefert werden, Kolben und Kolbenringe mit Übermaß. Kolbenringe werden nur satzweise geliefert, Kolben komplett mit Ringen, Kolbenbolzen und Sicherungsringen.

Angesichts fortgesetzter Weiterentwicklungen und Verbesserungen kann es vorkommen, daß ein gekauftes Teil nicht immer ganz dem abgebildeten gleicht.

Nicht alle Teile sind abgebildet, und wenn ein Teil ohne Teilnummer aufgeführt wird, wird es nur als Teil einer Baugruppe geliefert. Auch wenn eine Teilnummer angegeben ist, kann das betreffende Teil ggf. nicht allein, sondern nur als Baugruppe gekauft werden. Eingerückte Teile unter einer Eintragung gehören zu und bilden einen Teil einer Baugruppe.

Um dem Benutzer die Identifizierung von Teilen zu erleichtern, kommen die meisten Listen mit Abbildung, und die Einzelteile haben die gleiche Kennnummer wie in der Liste. Es ist daher darauf zu achten, daß immer auf das richtige Bild verwiesen wird.

Bei der Bestellung von Ersatzteilen ist nicht die Kennnummer der Abbildung, sondern die Teilnummer und die Seriennummer des Motors anzugeben.

Jeder Motor hat seine eigene Seriennummer, die auf einem Schild an der Luftkanalverkleidung eingestanzt ist. Diese Seriennummer ist vor Benutzung dieses Buches zu ermitteln, um sicherzustellen, daß das richtige Teil für den betreffenden Motor bestellt wird. Wenn der Bauartnummer eine 9 vorausgeht, ist der Motor entweder eine Sonderkonfiguration, oder er enthält nicht serienmäßige Teile und Zubehör.

Motorseriennummer



Seriennummerncode
 43 Baujahr
 00014 Seriennummer
 TS2 Typ
 A Linksdrehung
 001 Bauart

VORSICHT

Wenn Sie Teile bestellen, die nicht für Motoren TS oder TR zugelassen sind, können Sie sich nicht auf die richtigen Werkstoffe, Abmessungen und Ausführung verlassen.

Introducción - Español

El objeto de este Manual de Piezas Prototipo es dar una descripción de las piezas usadas en los motores de Lister-Petter TS y TR, junto a las modificaciones y alteraciones que se hayan efectuado.

Los cojinetes principales y los cojinetes de biela están disponibles en tamaños reducidos y los pistones y los aros de pistón en tamaños ampliados. Los aros de se suministran exclusivamente como juegos completos y los pistones se proporcionan completos con muñequillas y fiadores de perno.

Debido al continuo desarrollo y perfeccionamiento es muy posible que se adquiera alguna pieza que no asemejara totalmente a la ilustrada.

No todos los artículos tienen ilustración y si alguno figurara en lista y no tuviera número de pieza, es por que sólo está disponible como parte de una unidad completa. Aunque figurara el número de pieza, pudiera ser también que no estuviera disponible solo, sino como parte de una unidad completa. Los artículos que figuran sangrados debajo de una entrada están incluidos y forman parte de una unidad completa.

Con objeto de ayudar al usuario a identificar las piezas, la mayoría de las listas tienen una ilustración en la que las piezas individuales tienen el mismo número de referencia de artículo que el que aparece en la lista.

Para ordenar piezas de repuesto deberá citarse el Número de Pieza, no el número del artículo en la ilustración, y el Número de Serie del Motor.

Cada motor tiene un número de serie único, que lleva grabado en una placa fijada a la cubierta del aire. Resulta necesario comprobar el número de serie antes de hacer uso de este manual para asegurarse de que la pieza requerida es la adecuada para el motor del que se trate en particular. En los casos en los que el Número de Construcción vaya precedido de un 9, esto indica bien que el motor no es de configuración prototipo o bien que contiene piezas o accesorios que no lo son.

Placa de Número Serial



Código de Número de Serial
 43 Año
 00014 Número consecutivo de motor
 TS2 Modelo
 A Rotación antihorario
 001 Construcción de Motor

PRECAUCIÓN

No se puede tener confianza en que las piezas que no hayan sido aprobadas para usarse en TS o TR sean del material correcto o tengan las dimensiones o acabado apropiados.

Introduzione - Italiano

Lo scopo di questo Manuale dei Pezzi Principali è quello di dare una documentazione dei pezzi usati sui motori Lister-Petter TS e TR, assieme alle variazioni e modifiche che sono state effettuate.

I cuscinetti principali e i cuscinetti di biella sono disponibili minorati, mentre i pistoni e gli anelli sono disponibili maggiorati. Gli anelli dei pistoni sono forniti solo come gruppo completo e i pistoni sono completi di anelli, spinotto e anelli elastici di arresto.

A causa della linea di continuo sviluppo e perfezionamento, è possibile che un pezzo acquistato non sia esattamente come quello illustrato.

Non tutti gli articoli sono illustrati e se un articolo è elencato senza un numero categorico, è disponibile solo come parte di un complessivo. Anche quando un numero categorico è indicato, l'articolo non è necessariamente disponibile da solo, ma come complessivo. Gli articoli che sono indicati rientrati sotto un titolo sono inclusi in un complessivo e ne fanno parte.

Per aiutare l'utente ad identificare i pezzi, la maggior parte degli elenchi ha un'illustrazione con i pezzi individuali ai quali viene dato lo stesso numero di riferimento del pezzo che appare sull'elenco. Si dovrà fare attenzione di consultare l'illustrazione corretta.

I pezzi di sostituzione dovranno essere ordinati citando il numero categorico, non il numero d'articolo dell'illustrazione, e il numero di serie del motore.

Ciascun motore ha un numero di serie individuale che è stampato su una piastra attaccata alla cappottatura dell'aria. E' necessario identificare questo numero di serie prima di usare questo manuale per accertarsi che il pezzo richiesto sia corretto per il particolare motore. Quando il numero di costruzione è preceduto da un 9, ciò indica che il motore o presenta una configurazione non standard, o contiene pezzi o accessori non standard.

Numero di serie del motore



Seriennummerncode

- 43 Codice anno di fabbricazione
- 00014 Numero consecutivo di motore
- TS2 Modello
- A Rotazione in senso antiorario
- 001 Costruzione del motore

ATTENZIONE

I pezzi il cui uso non è stato approvato per i motori TS o TR non sono affidabili quanto a materiale, dimensioni o finitura.

Index - English

A

Accessory Kits	11-15
Accessory Kits (American) Lister-Petter Inc.	
Air Cleaner	132-151
Air Cowling	60-67
Air Duct.....	60-67
Air Shields	60-67
Alternator	98, 100
Ammeter	131

B

Battery Leads	182
---------------------	-----

C

Cable Looms - Protective Switches	182
Camshaft	34-36
Camshaft Bush	18
Charge Indicator	178, 179
Charge Windings - Nicsa	54
Charge Windings - Synchro	52
Clutch	152
Clutch Drive Member	158
Connecting Rod	30
Coupling	157, 159, 160
Crankcase	18-20
Crankshaft	30
Cylinder Barrel	30, 31
Cylinder Head	56, 58, 59

D

Decompressor Lever Insulation	185
Dipstick	18, 21
Dumper Accessories (Loose)	107

E

End Cover	43 - 45
Engine Controls	38
Engine Builds	16, 17
Exhaust Manifold	86, 88
Exhaust Manifold Adapters	89
Exhaust Pipe - Flexible	92
Exhaust Silencers	90, 91
Extension Shaft	110-113

F

Flat Belt Pulley	156
Flywheel and Fanshroud	46-51
Flywheel Charge Windings - Nicsa	54
Flywheel Charge Windings - Synchro	52
Fuel Control Solenoid	122-125
Fuel Filter	63, 72, 74
Fuel Injector	76
Fuel Lift Pump	68, 70
Fuel Pump	72, 74
Fuel Pump Linkage	38
Fuel Tank	80-84

G

Gauge Panel	126
Gear End Cover	42-45
Governor Lever Assembly	34, 36
Governor Linkage	38
Governor Weights	40, 41

H

Holding Down Bolts	190
Hydraulic Pump Adaptors	161-168

I

Injector	76
Inlet Manifold	86, 88
Introduction	2

J

Joint Sets	186-189
------------------	---------

K

Key Switch	178
Key Switch and Hour Recorder Panel.....	181
Key Switch Panel	180

L

Lagging	184, 185
Leak-off Pipe	76, 78
Lift Pump	68, 70

M

Main Bearings.....	18, 32, 33
Manifold Lagging	184, 185

O

Oil Distribution Block	116
Oil Distribution Block - Flexible Pipes	114
Oil Distribution Block - Steel Pipes	115
Oil Filter	26, 28
Oil Pressure Gauge	126
Oil Pump	26
Oil Strainer	26
Outlet Pipe Lagging	184

P

Piston	30
Power Take-Off	152

R

Remote Stop	106
Running Hour Recorder - Electrical	131
Running Hour Recorder - Vibration	130

S

SAE Adapter	156
Service Tools	190
Shaft Extension	110-113
Side Shield - Flywheel End	66
Silencer Lagging	184, 185
Silencers	90, 91
Speed Controls - Variable	102
Speeder Spring.....	38, 40, 41
Start Panels - Electric	170-177
Starter Motor	93, 94
Starting Handle	95, 96
Steel Fuel Pipes	78
Sump	20, 22-25

T

Temperature Gauge	129
Temperature Switch	118
Tool Kit.....	190
Two Speed Control	103, 104
Two Speed Solenoid	105

V

Valves	56, 57
--------------	--------

Index - Français

A	
Accessoires pour dumper (non monté)	107
Accouplement	157, 159, 160
Adaptateurs pour pompe hydraulique	161-168
Adaptateur SAE	156
Adaptateurs de collecteur d'échappement	89
Alternateur	98, 100
Ampèremètre	131
Arbre à cames	34-36
Arrêt à distance	106
Articulation de régulateur	38
B	
Bielle	30
Bloc de distribution d'huile moteur - tuyaux en acier	115
Bloc de distribution d'huile moteur - tuyaux flexibles	114
Bloc de distribution d'huile moteur	116
Bloc moteur	18-20
Boulons de fixation	190
C	
Câbles de batterie	182
Cadre d'entrée d'air	60-67
Cadres de sortie d'air	60-67
Carter de distribution	42-45
Carter d'huile	20, 22-25
Charge de batterie incorporé dans le volant moteur - Nicsa	54
Charge de batterie incorporé dans le volant moteur - Synchro	52
Collecteur d'admission	86, 88
Collecteur d'échappement	86, 88
Commandes moteur	38
Contacteur à clé	178
Contrôle de vitesse - variable	102
Contrôle deux vitesses	103, 104
Coussinet d'arbre à cames	18
Couvercle d'extrémité	43 - 45
Crépine à huile	26
Culasse	56, 58, 59
Cylindre	30, 31
D	
Démarrreur	93, 94
E	
Embrayage	152
Ensemble levier de régulateur	34, 36
Enveloppe calorifugée	184, 185
Enveloppe calorifugée pour collecteur d'échappement	184, 185
Enveloppe calorifugée sur pipe de sortie	184
Enveloppe d'échappement calorifugée pour silencieux d'échappement	184, 185
Extension d'arbre	110-113
F	
Faisceau de câbles avec sécurités	182
Filtre à combustible	63, 72, 74
Filtre à huile	26, 28
Filtres à air	132-151
H	
Horamètre - Electrique	131
Horamètre à vibrations	130
I	
Injecteur	76
Introduction	1
J	
Jauge de niveau d'huile	18, 21
K	
Kits d'accessoires	11-15
Kits d'accessoires (Etats-Unis) Lister-Petter Inc.	
L	
Levier de décompresseur calorifugé	185
M	
Manivelles	95, 96
Manomètre de pression d'huile	120
Masselottes centrifuges de régulateur	40, 41
Modèles des moteurs	16, 17
O	
Outils pour l'entretien moteur	190
P	
Paliers	18, 32, 33
Pièce de liaison de pompe d'injection	38
Pipe d'échappement - flexible	92
Piston	30
Plaques de protection d'air chaud	60-67
Plateau d'entraînement pour embrayage	158
Pochette de joints	186-189
Pompe à huile	26
Pompe d'élévation de combustible	68, 70
Pompe d'injection	72, 74
Poulie pour courroie plate	156
Prise de force	152
R	
Réservoir à combustible	80-84
Ressort de régulateur	38, 40, 41
S	
Sécurité de température	118
Silencieux d'échappement	90, 91
Solénoïde d'arrêt	122-125
Solénoïde deux vitesses	105
Soupapes	56, 57
T	
Tableau avec contacteur à clé	180
Tableau avec contacteur à clé et horamètre	181
Tableau de démarrage électrique	170-177
Tableau d'indicateurs	126
Témoin de charge batterie	178, 179
Thermomètre	129
Tôle latérale - côté volant	66
Trousse d'outillage	190
Tuyau de retour au réservoir	76, 78
Tuyaux d'alimentation de combustible en acier	78
V	
Vilebrequin	30
Volant et ventilateur monté sur volant	46-51

Sachverzeichnis - Deutsch

A		M	
Abdeckung	43 - 45	Motorbedienungselemente	38
Abgassammelrohr	86, 88	Motorbauarten	16, 17
Abgassammelrohr - Isolierung	184	N	
Abgassammelrohr Adapter	89	Nockenwelle	34-36
Abgasschlauch - flexibel	92	Nockenwellenlager	18
Abtrieb	152	O	
Amperemeter	131	Öldruckanzeige	120
Andrehkurbel	95, 96	Ölfilter	26, 28
Auspuffschalldämpfer	90, 91	Ölpeilstab	18, 21
B		Ölpumpe	26
Batteriekabel	182	Ölsieb	26
Befestigungsschrauben	190	Ölverteilstück - flexible Leitungen	114
Betriebsstundenzähler - elektrisch	131	Ölverteilstück - Stahlleitungen	115
D		Ölverteilerblock	116
Dekompressorhebelisolierung	185	Ölwanne	20, 22-25
Dichtungssätze	186-189	P	
Drehzahlfeder	38, 40, 41	Pleuelstange	30
Drehzahlregler - variabel	102	R	
Drehzahlregulierung / 2 Drehzahlen	103, 104	Reglergestänge	38
Drehzahlverstellmagnet / 2 Drehzahlen	105	Reglergewichte	40, 41
E		Reglerhebel-Baugruppe	34, 36
Einlaßkrümmer	86, 88	Rücklaufleitung	76, 78
Einleitung	2	S	
Einspritzdüse	76	SAE-Adapter	156
Einspritzpumpe	72, 74	Schlüsselschalter	178
Einspritzpumpengestänge	38	Schlüsselschalter- und Betriebsstundenzählertafel	181
F		Schlüsselschalterpanel	180
Flachriemenscheibe	156	Schwungrad und Kühlluftgehäuse	46-51
Förderpumpe	68, 70	Schwungradladewicklungen - Nicsa	54
H		Schwungradladewicklungen - Synchro	52
Hauptlager	18, 32, 33	Seitenabdeckung - Schwungradseitig	66
Hydraulikpumpenadapter	161-168	Stahlkraftstoffleitungen	78
I		Start Panel - elektrisch	170-177
Instrumententafel	126	Startermotor	93, 94
Isolierung	184, 185	Stirnradgetriebedeckel	42-45
K		Stopkabel (lose)	106
Kabelbaum - Schutzschalter	182	T	
Kipperzubehör (lose)	107	Temperaturanzeige	129
Kolben	30	Temperaturschalter	118
Kraftstoffbehälter	80-84	V	
Kraftstoffeinspritzdüse	76	Ventile	56, 57
Kraftstoffförderpumpe	68, 70	Verlängerungswelle	110-113
Kraftstofffilter	63, 72, 74	Vibrations-Betriebsstundenzähler	130
Kraftstoffsteuerung - Hubmagnet	122-125	W	
Krümmenisolierung	184, 185	Wartungswerkzeug	190
Kupplung	152, 157, 159, 160	Wellenverlängerung	110-113
Kupplungsmitnehmer	158	Werkzeugsatz	190
Kurbelgehäuse	18-20	Z	
Kurbelwelle	30	Zubehörsätze	11-15
L		Zubehörsätze (USA) Lister-Petter Inc.	
Ladeanzeige	178, 179	Zylinder	30, 31
Ladewicklungen - Nicsa	54	Zylinderkopf	56, 58, 59
Ladewicklungen - Synchro	52		
Lichtmaschine	98, 100		
Luffilter	132-151		
Luftführung	60-67		
Luftführungen	60-67		
Luftschilde	60-67		

Indice - Español

A		I	
Accesorios de Amortiguador (suelos)	107	Indicador de Carga	178, 179
Acoplador	157, 159, 160	Interruptor de Temperatura	118
Adaptador SAE	156	Introducción	2
Adaptadores de Bomba Hidráulica	161-168	Inyector de Combustible	76
Adaptadores de Colector de Escape	89	J	
Aislamiento	184, 185	Juego de Herramientas	190
Aislamiento de Palanca de Descompresor	185	Juegos de Uniones	186-189
Alternador	98, 100	K	
Amperímetro	131	Kits de Accesorios	11-15
Arranque de Llave y Panel de Registro de Horas	181	Kits de Accesorios (EE.UU.) Lister-Petter Inc.	
B		L	
Barrera Lateral - Extremo de Volante	66	Llave de Arranque	178
Barreras de Aire	60-67	M	
Bloque de Distribución de Aceite	116	Manivela de Arranque	95, 96
Bloque de Distribución de Aceite -		Miembro de Accionamiento de Embrague	158
Tuberías de Acero	115	Motor de Arranque	93, 94
Bloque de Distribución de Aceite -		Muelle de Velocímetro	38, 40, 41
Tuberías Flexibles	114	P	
Bobina de Cables - Interruptores de Seguridad ..	182	Panel de Arranque - Eléctrico	170-177
Bobinas de Carga - Nicsa	54	Panel de Arranque de Llave	180
Bobinas de Carga - Sincro	52	Panel de Indicadores	126
Bomba de Aceite	26	Parrilla de Aire	60-67
Bomba de Combustible	72, 74	Pernos de Fijación	190
Bomba de Elevación	68, 70	Pesos de Acelerador	40, 41
Bomba de Elevación de Combustible	68, 70	Pistón	30
C		Polea de Correa Plana	156
Cables de Batería	182	Presiómetro de Aceite	120
Cárter	18-20	R	
Casquillo de Eje de Levas	18	Registro de Horas en Marcha - Eléctrico	131
Cigüeñal	30	Registro de Horas en Marcha - Vibración	130
Cojinetes Principales	18, 32, 33	Revestimiento de Colector	184, 185
Colador de Aceite	26	Revestimiento de Silencioso	184, 185
Colector de Admisión	86, 88	Revestimiento de Tuberías de Salida	184
Colector de Escape	86, 88	S	
Conductos de Aire	60-67	Silencioso de Escape	90, 91
Conexión de Acelerador	38	Solenoides de Control de Combustible	122-125
Conexión de Bomba de Combustible	38	Solenoides de Doble Velocidad	105
Conjunto de Palanca de Acelerador	34, 36	Solenoides de Doble Velocidad	103, 104
Construcciones de Motor	16, 17	Stop Remoto	106
Control de Velocidad - Variable	102	Sumidero	20, 22-25
Controles de Motor	38	T	
Cubierta de Extremo de Engranajes	42-45	Tambor de Cilindro	30, 31
Culata de Cilindros	56, 58, 59	Tanque de Combustible	80-84
E		Tapa de Extremo	43-45
Eje de Extensión	110-113	Termómetro	129
Eje de Levas	34-36	Toma de Fuerza	152
Embrague	152	Tuberías de Combustible de Acero	78
Extensión de Eje	110-113	Tubo Contra Derrame	76, 78
F		Tubos de Escape - Flexibles	92
Filtro de Aceite	26, 28	V	
Filtro de Combustible	63, 72, 74	Válvulas	56, 57
Filtros de Aire	132-151	Varilla de Acoplamiento	30
H		Varilla Indicadora	18, 21
Herramientas de Servicio	190	Volante y Cubrimiento de Ventilador	46-51

Indice - Italiano

A		K	
Accessori autoribaltabile (Sciolti)	107	Kit accessori	11-15
Accoppiamento	157, 159, 160	Kit accessori (Stati Uniti) Lister-Petter Inc.	
Adattatore SAE	156	Kit attrezzi	190
Adattatori collettore scarico	89		
Adattatori della pompa idraulica	161-168	L	
Albero a camme	34-36	Leveraggio pompa d'alimentazione	38
Albero a gomiti	30	Leveraggio regolatore	38
Alternatore	98, 100		
Amperometro	131	M	
Asta di livello	18, 21	Manometro olio	120
Attrezzi di manutenzione	190	Manopola d'avviamento	95, 96
Avvolgimento carica batteria sul volano - Nicsa	54	Molla dispositivo di regolazione velocità ...	38, 40, 41
Avvolgimento carica batteria sul volano - Synchro	52	Motorino avviamento	93, 95
B		P	
Basamento	18-20	Pesi del regolatore	40, 41
Biella	30	Pistone	30
Blocco di distribuzione olio	116	Pompa aspirante d'alimentazione	68, 70
Blocco distribuzione olio - tubi d'acciaio	115	Pompa carburante	72, 74
Blocco distribuzione olio - tubi flessibili	114	Pompa d'alimentazione carburante	68, 70
Boccola albero a camme	18	Pompa dell'olio	26
Bulloni di fissaggio	190	Presa di forza	152
		Prolunga albero	110-113
C		Protezione laterale - Estremità volano	66
Cablaggio- Interruttori protettivi	182	Protezioni aria	60-67
Canna cilindro	30, 31	Puleggia cinghia piatta	156
Cavi Batteria	182		
Collettore d'entrata	86, 88	Q	
Collettore scarico	86, 88	Quadro avviamento - elettrico	170-177
Comandi motore	38	Quadro indicatori	126
Complessivo leva regolatore	34, 36	Quadro interruttore a chiavetta	180
Condotti di ventilazione	60-67	Quadro interruttore a chiavetta e contaore	181
Controllo con solenoide due velocità	103, 105		
Controllo velocità - variabile	102	R	
Coperchio distribuzione	43-45	Registratore ore funzionamento - Elettrico	131
Coperchio distribuzione ingranaggi	42-45	Registratore ore funzionamento - Vibrazione	130
Copertura pneumatica	60-67	Rivestimento	184, 185
Coppa	20, 22-25	Rivestimento collettore	184, 185
Cuscinetti principali	18, 32, 33	Rivestimento silenziatore	184, 185
		Rivestimento tubo d'uscita	184
E			
Elemento trasmissione frizione	158	S	
Estensione albero	110-113	Serbatoio carburante	80-84
		Serie guarnizioni	186-189
F		Silenziatore scarico	90, 91
Filtri dell'aria	132-151	Silenziatori	90, 91
Filtro carburante	63, 72, 74	Solenoide a due velocità	105
Filtro dell'olio	26, 28	Solenoide elettrostop controllo carburante ...	122-125
Frizione	152	Stili di motore	16, 17
I		T	
Indicatore carica	178, 179	Telearresto	106
Indicatore della temperatura	129	Testa cilindro	56, 58, 59
Iniettore carburante	76	Tubi d'acciaio carburante	78
Interruttore a chiavetta	178	Tubo di perdita	76, 78
Interruttore temperatura	118	Tubo scarico - flessibile	92
Introduzione	3		
Isolamento leva decompressore	185	V	
		Valvole	56, 57
		Volano e protezione ventilatore	46-51

Accessory Kits

Some accessory kits are not compatible with others or suitable for all engine builds. In some instances more than one accessory kit code is included in the listings on a page. In these cases care must be taken to check the details given in 'Description of Accessory Kit' to help

identify the kit items needed, as more items than are actually required in a specific accessory kit may be listed. **Please Note:** All Marine Accessories shown in this listing are not included in this manual. For further information refer to Lister-Petter.

Adaptors

Code	Description of Accessory Kit	Kit Part Number	Page
CA	SAE4, SAE5 Fanshroud Ventilated Adaptor Ring - 51mm	570-31590	156
CB	SAE4 Fanshroud Ventilated Adaptor Ring - 51mm	570-31600	156
DA	Air outlet duct adaptor - TS/TR1	570-32820	60
	Air outlet duct adaptor - TS/TR2	570-31670	64
	Air outlet duct adaptor - TS/TR3	570-32090	64
DF	Flywheel end side shield - for use with codes JC or PF - TS/TR1	570-33770	66

Air Cleaners

Code	Description of Accessory Kit	Kit Part Number	Page
AA	Medium duty dry type - paper element TS/TR1	570-33740	132
	Medium duty dry type - paper element TS/TR2,3 (TR3 up to 1800r/min)	570-31381	132
AO	Medium duty dry type - paper element TR3 above 1801r/min only	570-36100	132
AB	Medium duty dry type - foam element TS/TR2,3	570-31391	133
AJ	Medium duty dry type - to suit TS/TR1 13,5 litre fuel tank, includes Codes AA and AS ..	570-33750	138
AK	Medium duty oil bath type - TS/TR1, use with Code AS	570-32770	151
AR	Medium duty oil bath type - TS/TR2	570-36901	151
	Medium duty oil bath type - TS/TR3 (TR3 up to 2000r/min	570-36902	151
AC	Heavy duty dry type - TS/TR1, not for use with Code FB	570-41580	136
AD	Heavy duty dry type - TS/TR2,3		
	TS/TR2	570-35651	142
	TS/TR3	570-35652	142
AG	Remote mounted heavy duty dry type - TS/TR2,3	570-41670	148
AE	Heavy duty dry type - gear end mounted, TS/TR2,3		
	TS/TR2	570-41611	146
	TS/TR3	570-41612	146
AN	Heavy duty oil bath air cleaner - TS/TR1	570-33880	150
AP	Inlet manifold adaptor - spigot diameter 2 1/4" (57,1mm) for standard manifold, TS/TR2,3 ..	570-41730	86
AX	Inlet manifold with gear end flange - TS/TR2	570-32560	86
	Inlet manifold with gear end flange - TS/TR3	570-32570	86
AT	Inlet manifold with gear end spigot - TS/TR2	570-41991	86
	Inlet manifold with gear end spigot - TS/TR3	570-41992	86
AS	Inlet manifold with vertical flange - TS/TR1	570-32760	86

Controls - Industrial

Code	Description of Accessory Kit	Kit Part Number	Page
KA	Variable speed control - 1,8m cable and lever		
	TS/TR1	570-32870	102
	TS/TR2,3	570-31901	102
KB	Variable speed control - engine mounted	570-31911	101
KC	Variable speed control - less cable and lever, TS/TR1	570-32900	102
	Variable speed control - less cable and lever, TS/TR2,3	570-31921	102
KD	Remote stop - 1,8m cable operated, TS/TR1	570-33180	106
	Remote stop - 1,8m cable operated, TS/TR2,3	570-31930	106
KE	Adaptor for electronic governor - TS/TR2,3	570-33080	108
KG	Manual two speed control - not for use with solenoid Code JE - TS/TR1	570-33200	103
	Manual two speed control - not for use with solenoid Code JE - TS/TR2,3	570-33460	104
XD	Dumper accessories (loose)	570-41310	107

Controls - Marine

Code	Description of Accessory Kit	Kit Part Number	Page
MKH	Engine fittings for control cable	570-60520	-
MKA	2m control cable	570-60070	-
MKB	3m control cable	570-60040	-
MKC	4m control cable	750-60050	-
MKD	5m control cable	750-60060	-
MKF	Single lever, side mounted control head	750-60020	-
MKE	3m cable operated remote stop	750-60030	-

Accessory Kits

Drives - Flywheel End

Code	Description of Accessory Kit	Kit Part Number	Page
BA	Long crankshaft extension - 40mm diameter	570-31460	110
BB	Short crankshaft extension - 40mm diameter, TS/TR1 only	602-51620	110
BC	Crankshaft extension - unmachined	570-31470	110
BE	Heavy duty overcentre clutch PTO	570-31480	154
BF	Flat belt pulley	570-37460	156
BN	Flat belt pulley - TS3	570-37460	156
CL	7 $\frac{1}{2}$ " (190mm) drive member for alternator or overcentre clutch	570-31650	154
BN	Bolt on 7" (178mm) diameter pulley - TS/TR1	570-32950	156
CH	8" (203mm) Automotive clutch drive member - use with adaptor Code CA or CB	570-31630	158
CI	9" (229mm) Automotive clutch drive member - use with adaptor Code CA or CB	570-31640	158
BO	Flexible half coupling - less taper lock bush	570-31520	157
BL	Flexible half coupling - solid boss	601-53920	157
BQ	Flexible half coupling for 35mm shaft, supplied with taper lock bush	570-31540	157
BR	Flexible half coupling for 38mm shaft, supplied with taper lock bush	570-31550	157
BS	Flexible half coupling for 42mm shaft, supplied with taper lock bush	570-31560	157
BX	As Code BO but with harder element	570-31521	157
CY	Extra flexible coupling for TR2 1500r/min generating sets for 35mm shaft - TS/TR2 ..	570-34670	160
XA	Shaft extension - TS/TR2,3	570-32880	112

Gear End Drive

Code	Description of Accessory Kit	Kit Part Number	Page
BW	Crankshaft extension - 40mm diameter	570-31580	111

Exhaust Equipment - Industrial

Code	Description of Accessory Kit	Kit Part Number	Page
NA	Medium duty silencer - includes Code NJ on TS/TR2,3 TS/TR1	570-31170	90
	TS/TR2,3	570-31960	90
NL	Medium duty silencer - TS/TR1 Build 16 only	570-13980	90
NB	Heavy duty silencer - TS/TR2,3, use with Code AE or AX	570-32400	91
NC	Heavy duty silencer - supplied loose	570-15780	90
NE	1m Flexible exhaust pipe	570-32410	92
NG	Vertical manifold adaptor - TS/TR1	570-32980	89
	Vertical manifold adaptor - TS/TR2,3	570-31980	89
NJ	Horizontal manifold adaptor - TS/TR2,3	570-31990	89
NF	Manifold flange - TS/TR1 tapped 1 $\frac{1}{2}$ " BSP	570-32970	89
	Manifold flange - TS/TR2,3 tapped 1 $\frac{1}{2}$ " BSP	570-31970	89
NH	Exhaust outlet bend - use with Code NA if required	570-32520	90
NM	Heat Shield	570-41720	90

Exhaust Equipment - Marine

Code	Description of Accessory Kit	Kit Part Number	Page
MNC	Dry type exhaust silencer	750-60280	-
MND	Skin fittings for dry exhaust	750-60190	-

Fuel Equipment

Code	Description of Accessory Kit	Kit Part Number	Page
FA	8,25 litre fuel tank - TS/TR1	570-32791	80
FB	13,5 litre fuel tank - TS/TR1	570-35691	84
	13,5 litre fuel tank - TS/TR2	570-35692	84
	13,5 litre fuel tank - TS/TR3	570-35693	84
FD	25,0 litre fuel tank - supplied loose	570-32641	84
FE	Fuel lift pump - TR/TS1	570-32810	70
	Fuel lift pump - TR/TS2	570-34690	70
	Fuel lift pump - TR/TS3	570-34700	70
FF	Fuel filter/agglomerator - in lieu of standard filter - TS/TR2,3	570-34650	74
FH	Steel fuel lines - TS/TR2	570-33020	78
	Steel fuel lines - TS/TR3	570-33030	78
MFA	45.5 litre cylindrical fuel tank	750-60260	-
MFB	113.5 litre oblong fuel tank	750-60290	-
MFC	Flexible fuel connections - 0.46 metre	570-60060	-
MFD	Steel supply and leak off pipes - 2.4 metres	750-60270	-
MFF	Duplex fuel filter	570-60070	-

Accessory Kits

Gauges

Code	Description of Accessory Kit	Kit Part Number	Page
PE	Oil pressure gauge	570-32011	128
PF	Air temperature gauge	570-32020	129
PG	Running hour recorder - 12V/24V	570-30520	131
PK	Running hour recorder - vibration type - TS/TR2,3	570-32030	130
PA	2 gauge panel - less gauges	570-32421	126
MPA	Oil pressure and engine temperature gauges with remote panel (1.83m)	570-60100	-
MPB	Oil pressure gauge and fittings (no panel) - TS2	570-60440	-

Gearbox & Gearbox Couplings - Marine

MVB	Hurth HBW100 Gearbox, adaptors and drive member (ratio 1.79:1) - TS2	570-60110	-
MVB	Hurth HBW150 Gearbox, adaptors and drive member (ratio 1.88:1) - TS3	570-60350	-
MVC	Hurth HBW125 Gearbox, adaptors and drive member (ratio 2.14:1)	570-60470	-
MVG	Newage PRM 150 D2 Gearbox, adaptors and drive member (ratio 2.09:1)	570-60720	-
MVK	Newage PRM 260 D2 Gearbox, adaptors and drive member (ratio 1.96:1) - TS2	570-60130	-
	Newage PRM 260 D2 Gearbox, adaptors and drive member (ratio 1.96:1) - TS3	570-60370	-
MVE	Hurth HBW100 Gearbox, adaptors and drive member (ratio 2.72:1) - TS2	570-60120	-
	Hurth HBW100 Gearbox, adaptors and drive member (ratio 2.74:1) - TS3	570-60360	-
MVF	Hurth HBW125 Gearbox, adaptors and drive member (ratio 2.63:1)	570-60450	-
MVH	Newage PRM 150 D3 Gearbox, adaptors and drive member (ratio 2.82:1)	570-60730	-
MVL	Newage PRM 260 D3 Gearbox, adaptors and drive member (ratio 2.94:1) - TS2	570-60140	-
	Newage PRM 260 D3 Gearbox, adaptors and drive member (ratio 2.94:1) - TS3	570-60380	-
MYA	Solid coupling (pilot bored) to suit Hurth HBW or Newage PRM Delta	570-60260	-
MYP	Solid coupling (pilot bored) to suit Newage PRM 260	570-60270	-
MYQ	Flexible coupling (pilot bored) to suit Hurth HBW or Newage PRM Delta	570-60280	-
MYK	Flexible coupling (pilot bored) to suit Newage PRM 260	570-60290	-

Guards - (exhaust & manifold lagging, to meet EEC machinery Directive 89/392/EEC)

Code	Description of Accessory Kit	Kit Part Number	Page
GQ	Lagging for manifold only (not build 16) - TS/TR1	570-37060	184
	Lagging for manifold only (not build 16) - TS/TR2	570-37100	184
	Lagging for manifold only (not build 16) - TS/TR3	570-37140	184
GR	Lagging for manifold and silencer code NA - TS/TR1	570-37070	184
	Lagging for manifold and silencer code NA - TS/TR2	570-37110	184
	Lagging for manifold and silencer code NA - TS/TR3	570-37150	184
GW	Lagging for manifold, silencer code NA, and outlet pipe code NH - TS/TR1	570-37080	184
	Lagging for manifold, silencer code NA, and outlet pipe code NH - TS/TR2	570-37120	184
	Lagging for manifold, silencer code NA, and outlet pipe code NH - TS/TR3	570-37160	184
GX	Lagging for manifold and silencer code NL (build 16 only) - TS/TR1	570-37090	185
GU	Lagging for manifold and manifold flange code NF - TS/TR2	570-37130	185
	Lagging for manifold and manifold flange code NF - TS/TR3	570-37220	185
GH	Decompressor lever insulation	570-72350	185

Gear End Hydraulics - (for use with Builds 06,07,66 only)

Code	Description of Accessory Kit	Kit Part Number	Page
HF	Dowty 1P3000 hydraulic pump (or equivalent) - 15bhp limit		
	TS/TR1	570-41530	162
	TS/TR2,3	570-41540	162
HI	SAE A hydraulic pump - 15bhp limit	570-41550	164

Flywheel End Hydraulics

Code	Description of Accessory Kit	Kit Part Number	Page
HH	Dowty 1P3000 hydraulic pump (or equivalent)	570-31830	166
HK	Dowty 2P3000 hydraulic pump (or equivalent)	570-31850	166

Hydraulic Pump Adaptor Kit

Code	Description of Accessory Kit	Kit Part Number	Page
HN	Hydraulic Pump Adaptor Kit	570-35750	161

Accessory Kits

Lubrication Equipment - Industrial

Code	Description of Accessory Kit	Kit Part Number	Page
LA	Extended running equipment - TS/TR1	570-31160	22
	Extended running equipment - TS/TR2	570-31940	22
	Extended running equipment - TS/TR3	570-32150	22
LB	Remote mounted oil filter	570-31950	28
JG	Oil distribution block - TR2	570-37360	116
LG	Oil distribution block - flexible feed pipe	570-17100	114
LF	Oil distribution block - steel feed pipe - TS/TR2,3	570-33090	115
LJ	Sump with provision for heater and thermostat TS/TR2	570-33540	25
	Sump with provision for heater and thermostat TS/TR3	570-33550	25
LP	5 litre sump (in lieu of std sump) - TS/TR1	570-35550	24
LQ	Extended dipstick (in lieu of std dipstick) - use with code LP - TS/TR1	570-35560	21

Lubrication Equipment - Marine

Code	Description of Accessory Kit	Kit Part Number	Page
MLC	High level dipstick	570-60550	-
MLD	Oil filter blanking plate	570-60190	-
MLE	Sump oil drain pump - TS2	570-60180	-
	Sump oil drain pump - TS3	570-60390	-

Mountings - Industrial

Code	Description of Accessory Kit	Kit Part Number	Page
QA	Holding down bolts	570-14070	190
QD	Cylinder head cover - gear end with mounting facility	570-35890	58
QF	Sump with side mounting pads in lieu of standard sump - TS/TR2	570-35490	20
	Sump with side mounting pads in lieu of standard sump - TS/TR3	570-35500	20

Mountings - Marine

Code	Description of Accessory Kit	Kit Part Number	Page
MQB	Gear end bearers	570-60540	-
MQE	Flywheel end bearers	570-60530	-
MQG	Tico absorbent Mounting Pads	570-60210	-

Protection Devices and Solenoids

Code	Description of Accessory Kit	Kit Part Number	Page
High Engine Temperature Switches			
JA	Cylinder head temperature switch - up to 1850r/min, NC contacts	570-34200	118
JB	Cylinder head temperature switch - above 1851r/min, NC contacts	570-32390	118
JM	Cylinder head temperature switch - up to 1850r/min, NO contacts	570-36820	118
JK	Cylinder head temperature switch - NC contacts	570-42170	118
JC	Airstream sensor - TS/TR1	570-33220	118
	Airstream sensor - TS/TR2,3	570-30540	118
JD	Low lubricating oil pressure switch - includes Code LG	570-30512	120
JE	Fuel control solenoid - TS/TR1	570-32841	124
	Fuel control solenoid - TS/TR2,3	570-31882	122
JG	Oil distribution block and pressure switch	570-37360	116
WC	Wiring Loom - for protection switches Code JD with JA or JB - TS/TR2,3	570-30982	182

Accessory Kits

Starting Equipment - Industrial

Code	Description of Accessory Kit	Kit Part Number	Page
EA	Starting handle - gear end - short grip - TS/TR1,2	601-53350	95
EB	Starting handle - gear end - long grip	570-31690	95
ED	Starting handle - gear end hydraulics (assembled)	570-31710	95
EF	Starting handle - gear end hydraulics (kit form)	570-31730	95
ER	Starting handle - gear end - limited kickback	570-35724	96
EX	Starting handle - gear end hydraulics -limited kickback (kit form not available)	570-35725	96
EK	12V pre-engaged starter motor - includes Code EM	570-30421	93
WA	Electric start panel - wired to starter motor/regulator with provision for two additional gauges - see Codes PE, PF, PG)		
	Electric start panel - TS/TR1	570-33782	176
	Electric start panel - TS/TR2,3	570-30553	176
WM	Electric start panel complete - supplied loose		
	Synchro	602-51752	170
	Nicsa	570-35441	174
WL	Charging indication lamp - Builds 02,07,09,11,15,61,63,66	570-35450	178
WK	Keyswitch and Charge Indicator	572-56250	178
EL	24V pre-engaged starter motor - includes Code EM	570-30431	93
EJ	Coupled decompressors - TS/TR2	570-31740	56
	Coupled decompressors - TS/TR3	570-32100	56
EM	Spacer for starter motor with SAE1 flange	570-31750	93
EN	Spacer for air, hydraulic and Delco starters	570-31760	95
EP	Alternator - TS2,3	570-35760	100
EU	Cold start oil cups - fitted as standard on TR2,3		
	Cold start oil cups - TR/TS1	570-32830	60
	Cold start oil cups - TS/TR2	570-31770	64
	Cold start oil cups - TS/TR3	570-32110	64
EY	Non hand start gear end cover	570-72411	42
WG	Keyswitch and panel - not for use with Code JE, or builds without charge windings		
	TS/TR1	570-34626	180
	TS/TR2,3	570-34627	180
WI	Keyswitch and electric running hour recorder in panel - not for use with Code JE or builds without charge windings		
	TS/TR1	570-36860	181
	TS/TR2,3	570-36850	181
WO	Battery leads	570-13880	182

Starting Equipment - Marine

Code	Description of Accessory Kit	Kit Part Number	Page
MEG	Starting handle (for use with code MER)	570-60340	-
MER	Raised hand start (use with code MEG) - TS2	570-60250	-
	Raised hand start (use with code MEG) - TS3	570-60400	-
MEH	12V Starter motor and push button - insulated return	570-60230	-
MEK	12V Starter motor and 55 Amp alternator - insulated return	570-60220	-
MWA	Start Panel with warning lights and keyswitch	570-60080	-
MEX	Cold start primer - automatic - TS2	570-60480	-
	Cold start primer - automatic - TS3	570-60500	-

Sundries - Industrial

Code	Description of Accessory Kit	Kit Part Number	Page
SD	Transfer kit	570-41302	-
SJ	Tool kit	570-32490	190
XC	Tool kit	570-41750	190

Sundries - Marine

Code	Description of Accessory Kit	Kit Part Number	Page
MSG	Jabsco 1" bilge pump, belt driven with clutch, supplied loose with belt and pulley	570-60300	-
MSH	Anti roll equipment (22 degrees) - TS2	570-60490	-
	Anti roll equipment (22 degrees) - TS3	570-60510	-

TS Engine Builds

Some Builds may not be available in all engines or cylinder configurations.

Where the build number is preceded by a 9 this indicates that the engine is either of a non-standard configuration, or contains non-standard parts or accessories.

When new parts are required for such a build it is suggested that reference be made to Lister-Petter to determine the exact engine specification and which parts are non-standard.

Build	Detail
01	Variable speed up to 2500 r/min* with no overload
02	Variable speed up to 2500 r/min* with no overload
03	Variable speed up to 3000 r/min with no overload, high speed flywheel
04	Variable speed up to 3000 r/min with no overload
05	Variable speed up to 2500 r/min with overload, provision for hydraulic pump
06	Variable speed up to 2500 r/min* with overload, provision for hydraulic pump
07	Variable speed up to 2500 r/min* with overload, provision for hydraulic pump
08	Genset Build - 1500 r/min with overload
09	Fixed speed 1500 r/min with overload, heavy flywheel
10	Genset Build - 1800 r/min with overload
11	Genset Build - 1800 r/min with overload
12	Genset Build - 3000 r/min with overload
13	Genset Build - 3000 r/min with overload
14	Variable speed - up to 2500 r/min with overload, dumper build
15	Variable speed - up to 2500 r/min with overload, dumper build
16	Variable speed - up to 2000 r/min with overload, sheetmetal fanshroud
18	Genset Build - up to 2200 r/min with no overload
40	Variable Speed - up to 2600 r/min with no overload, marine build
41	Variable Speed - up to 2000 r/min with no overload, marine build
42	Variable Speed - up to 2600 r/min with no overload, marine build
60	Variable speed - up to 2500 r/min with no overload, low noise Q Build
61	Variable speed - up to 2500 r/min* with no overload, low noise Q Build
62	Fixed speed - 1500 r/min with overload, low noise Q Build
63	Fixed speed - 1500 r/min with overload, low noise Q Build
64	Fixed speed - 1800 r/min with overload, low noise Q Build
65	Fixed speed - 1800 r/min with overload, low noise Q Build
66	Fixed speed - 1500 r/min with overload, low noise Q Build, provision for hydraulic pump
78	Fixed speed - 1500 r/min with overload
101	Fixed speed - 1500 r/min with overload
102	Variable speed - 2500 r/min with no overload
103	Variable speed - 2500 r/min with no overload
104	Variable speed - 2500 r/min with overload

TR Engine Builds

Some Builds may not be available in all engines or cylinder configurations.

Where the build number is preceded by a 9 this indicates that the engine is either of a non-standard configuration, or contains non-standard parts or accessories.

When new parts are required for such a build it is suggested that reference be made to Lister-Petter to determine the exact engine specification and which parts are non-standard.

Build	Detail
01	Variable speed up to 2500 r/min* with no overload
02	Variable speed up to 2500 r/min* with no overload
03	Variable speed up to 3000 r/min with no overload, high speed flywheel
04	Variable speed up to 3000 r/min with no overload
05	Variable speed up to 2500 r/min with overload, provision for hydraulic pump
06	Variable speed up to 2500 r/min* with overload, provision for hydraulic pump
07	Variable speed up to 2500 r/min* with overload, provision for hydraulic pump
08	TR1 - Genset Build - 1500 r/min with overload, heavy flywheel TR2,3 - Genset Build - up to 1800 r/min with overload, heavy flywheel
09	Fixed speed up to 1500 r/min with overload
10	Genset Build - 1800 r/min with overload
11	Genset Build - 1800 r/min with overload
12	Fixed speed - 3000 r/min with overload, high speed flywheel
13	Fixed speed - 3000 r/min with overload, high speed flywheel
14	TR1 - Variable speed - up to 2500 r/min with overload TR2 - Variable speed - up to 2000 r/min with no overload
15	TR1 - Variable speed - up to 2500 r/min with overload TR2 - Variable speed - up to 2000 r/min with no overload
16	Variable speed - up to 2500 r/min with overload, sheetmetal fanshroud
18	Genset Build - up to 2200 r/min with no overload
50	Fixed Speed - up to 2500 r/min with no overload
78	Fixed speed - 1500 r/min with overload
101	Fixed speed - 1500 or 1800 r/min with overload

Crankcase

Illustration T5 No.	Description	Part Number	TS/TR			Remarks
			1	2	3	
-	Crankcase Assembly - TS/TR1	570-33140	1	-	-	See Note
1	Crankcase Assembly - TS2	570-30560	-	1	-	See Note
-	Crankcase Assembly - TS3	570-30570	-	-	1	See Note
-	Crankcase Assembly - TR2	570-30780	-	1	-	See Note
-	Crankcase Assembly - TR3	570-30790	-	-	1	See Note
-	Crankcase Assembly - TS/TR2	570-30781	-	1	-	Build 80 with side door
-	Crankcase Assembly - TS/TR3	570-30791	-	-	1	Build 80 with side door
-	Door	202-45480	-	2	3	Build 80
-	Setscrew - M6 x 16mm	272-00034	-	8	12	Build 80
-	Spring Washer	272-00070	-	8	12	Build 80
2	Main Bearings	570-30010	1	1	1	
-	Main Bearings - 0,25mm undersize	570-30010/025	1	1	1	
-	Main Bearings - 0,50mm undersize	570-30010/050	1	1	1	
-	Main Bearings - 0,75mm undersize	570-30010/075	1	1	1	
-	Main Bearings - 1,00mm undersize	570-30010/100	1	1	1	
3	Flywheel End Camshaft Bush	201-30250	1	1	1	
4	Flywheel End Plug	201-39810	1	1	1	
5	Centre Camshaft Bush	202-12030	-	1	2	
6	Camshaft Bore Expansion Plug	201-47290	1	1	1	Replaces 027-06116
7	Gear End Plug	027-01604	1	1	1	
8	Dipstick Assembly	027-06874	1	1	1	Replaces 570-10200
9	'O' Ring	201-13120	1	1	1	
10	Lubricating Oil Pipe	202-30571	1	1	1	
-	Fuel Pump Inspection Door					
-	TS/TR1	201-39690	1	-	-	
11	TS/TR2, 3 - Gear End	202-30600	-	1	1	Replaces 201-30590
12	TS/TR2, 3 - Flywheel End and Centre	202-30600	-	1	2	
-	Joint - TS/TR1	201-39701	1	-	-	Replaces 201-39700
13	Joint - TS/TR2, 3	201-30612	-	2	3	
14	Washer	272-00364	4	7	11	
-	Setscrew - M6 x 16mm - TS/TR1	272-00034	4	-	-	
15	Setscrew - M6 x 14mm - TS/TR2, 3	272-00033	-	7	11	
16	Stopping Lever Spring	201-38010	1	1	1	
17	Washer	027-00618	-	1	1	
18	Setscrew - M6 x 16mm	272-00034	-	1	1	
19	Stiffener	201-42650	1	-	-	
20	Fuel Lift Pump Blanking Plate	602-36710	1	1	1	
21	Blanking Plate Joint	602-36721	1	1	1	
22	Spring Washer	272-00071	4	4	4	
23	Setscrew - M8 x 14mm	272-00037	4	4	4	
24	Governor Lever Pivot	201-31141	2	2	2	

Note:

These part numbers replace all previous crankcase assembly part numbers for standard builds.

Continued

Illustration T5

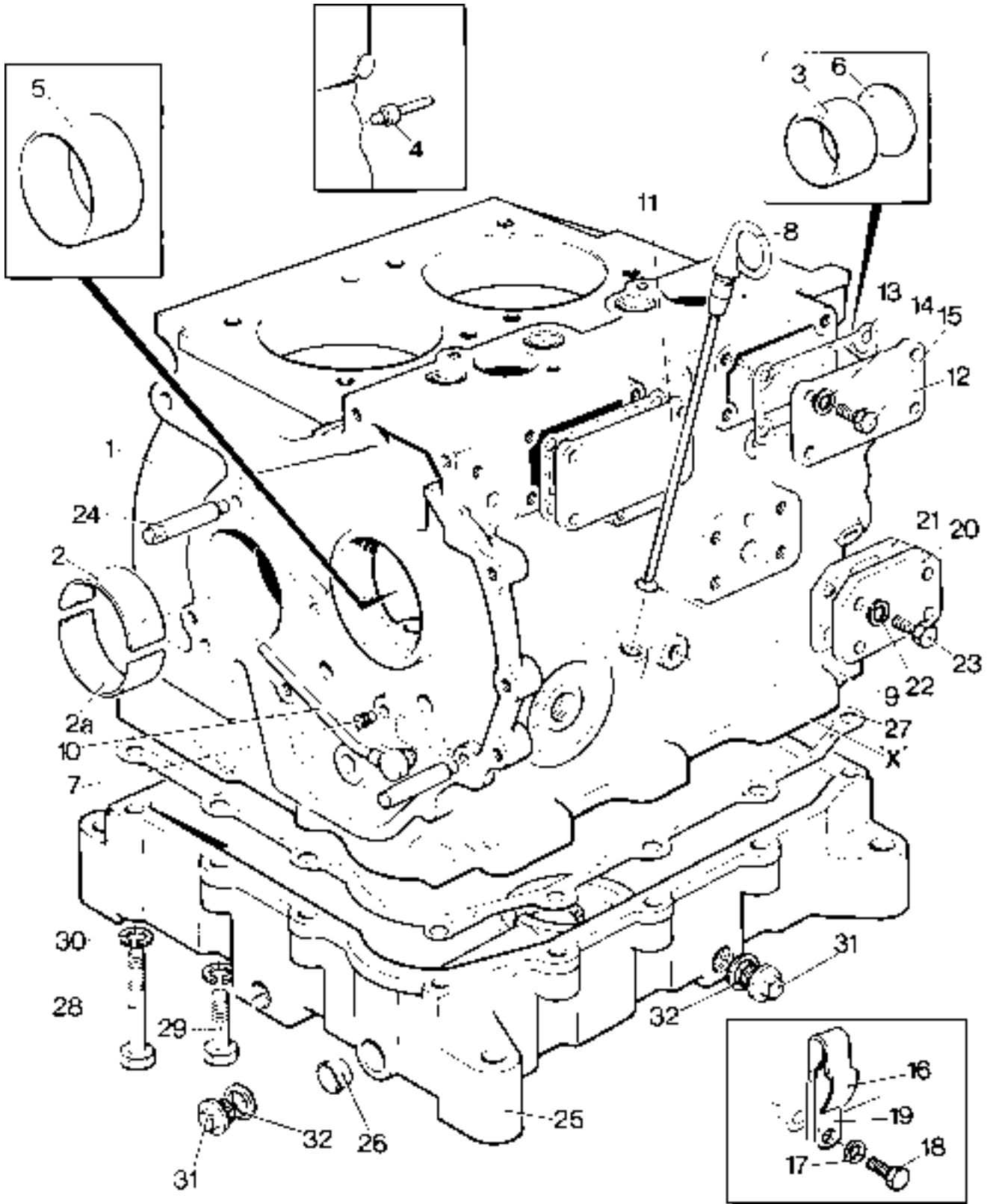

Crankcase continued

Illustration T5 No.	Description	Part Number	TS/TR			Remarks
			1	2	3	
-	Sump - TS/TR1	570-33710	1	-	-	Not Builds 40,42
25	Sump - TS/TR2	570-33590	-	1	-	Not Builds 40,42
-	Sump - TS/TR3	570-33600	-	-	1	Not Builds 40,42
-	Sump - TS/TR1	570-33860	1	-	-	Build 40
-	Sump - TS/TR2	570-33592	-	1	-	Build 40
-	Sump - TS/TR3	570-33602	-	-	1	Build 40
-	Sump - TS/TR2	202-42510	-	1	-	Builds 42
-	Sump - TS/TR3	203-42510	-	-	1	Builds 42
	Accessory Kit Code QF - TS/TR2	570-35490	-	1	-	With side mounting pads
	Sump	570-41900	-	1	-	
	Accessory Kit Code QF - TS/TR3	570-35500	-	-	1	With side mounting pads
	Sump	570-41890	-	-	1	
26	Expansion Plug	351-41510	1	1	1	Not Build 42
-	Joint - TS/TR1	201-37751	1	-	-	
27	Joint - TS/TR2	202-30541	-	1	-	
-	Joint - TS/TR3	203-30542	-	-	1	
28	Bolt - M8 x 75mm	272-00047	4	4	4	
29	Bolt - M8 x 35mm	272-00042	8	10	14	
30	Spring Washer	272-00071	12	14	18	
31	Drain Plug	201-47470	1	2	2	Replaces 007-00407
32	Copper Washer	013-21778	1	2	2	
-	Drain Plug - 1/2" BSP	027-00140	1	1	1	Build 40
-	Drain Plug - 1/2" BSP	027-00140	-	5	8	Build 42
-	Flanged Drain Plug - 1" BSP	003-00140	1	1	1	Build 40,42. Replaces 027-00142
-	Copper Washer	616-01524	1	1	1	Build 40,42

Extended Dipstick (in lieu of standard dipstick) - TS/TR1

Illustration T421
No. Description

TS/TR
1 2 3 Remarks

	Accessory Kit Code LQ	570-35560	1	-	-	
1	Dipstick Assembly	027-07948	1	-	-	
2	Dipstick Assembly	201-47171	1	-	-	
3	Bolt - M8 x 80mm	272-00128	1	-	-	
4	Washer	027-00082	4	-	-	
5	'O' Ring	201-13120	1	-	-	

Note:
For other reference to Dipstick see 'Crankcase' section.

Illustration T421

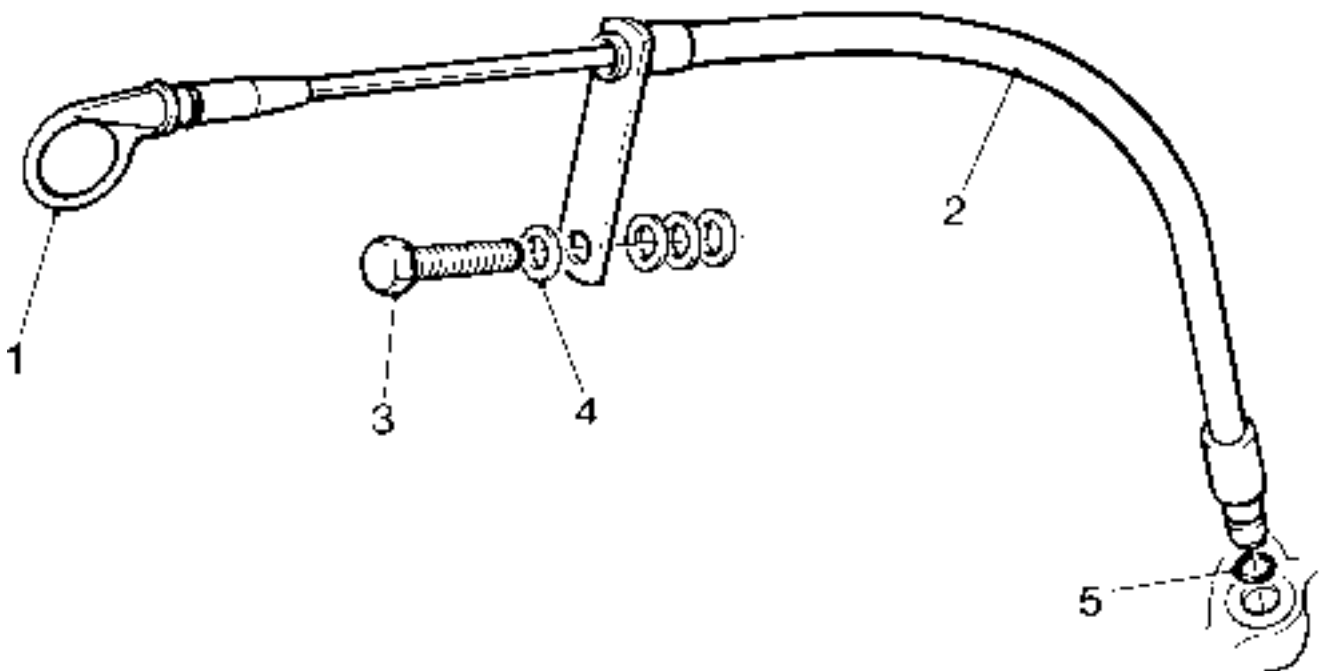

Dry Sump

Illustration T198 No.	Description	Part Number	TS/TR			Remarks
			1	2	3	
	Accessory Kit Code LA - TS/TR1	570-31160	1	-	-	
	Accessory Kit Code LA - TS/TR2	570-31940	-	1	-	
	Accessory Kit Code LA - TS/TR3	570-32150	-	-	1	
1	Lubricating Oil Pump Cylinder	602-20611	1	1	1	
2	'O' Ring	366-07720	1	1	1	
-	Sump - TS/TR1	201-37743	1	-	-	
3	Sump - TS/TR2	366-07076	-	1	-	
-	Sump - TS/TR3	366-07077	-	-	1	
-	Joint - TS/TR1	201-37751	1	-	-	
4	Joint - TS/TR2	202-30541	-	1	-	
-	Joint - TS/TR3	203-30542	-	-	1	
5	Union Connection	351-40700	1	1	1	
6	Copper Washer	291-30640	1	1	1	
7	Union Connection	010-02085	1	1	1	
8	Copper Washer	013-21778	1	1	1	
9	Vent Pipe Adaptor	027-04569	1	1	1	
10	Drain Plug	007-00407	1	2	2	
11	Copper Washer	013-21778	1	2	2	

Illustration T198

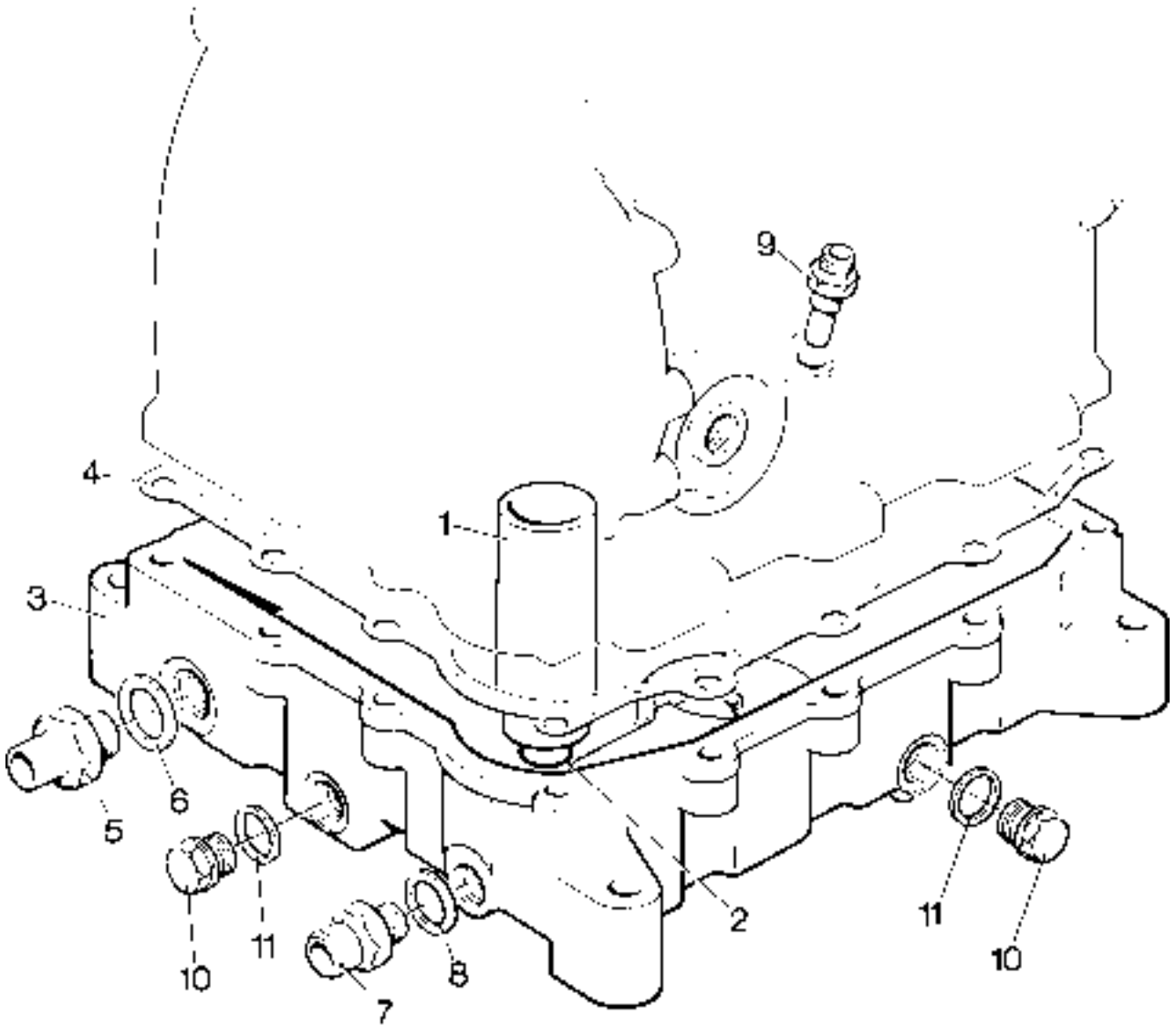

5 Litre Deep Sump (in lieu of standard sump) - TS/TR1

Illustration T424

Description

Part Number

TS/TR

1 2 3 Remarks

Accessory Kit Code LP	570-35550	1	-	-	
- 5 Litre Sump Assembly	201-47140	1	-	-	
1 5 Litre Sump	201-47110	1	-	-	
2 Oil Pump Pedestal	201-47130	1	-	-	
3 Expansion Plug	201-39810	1	-	-	
4 Caphead Bolt	272-00770	12	-	-	
5 Copper Washer 1/2" BSP	013-21778	1	-	-	
6 Joint	201-37751	1	-	-	
7 Dipstick Assembly	027-07946	1	-	-	
8 Lubricating Oil Pump Cylinder	602-20611	1	-	-	
9 'O' Ring Seal	366-07720	1	-	-	
- Strainer Mesh	202-33740	1	-	-	See Note
- Cap Assembly	602-36820	1	-	-	See Note
- Setscrew - M8 x 14mm	272-00037	1	-	-	See Note
- Spring Washer	272-00071	1	-	-	See Note
- Drain Plug	007-00407	1	-	-	See Note

Note:

If sump is being fitted to replace standard sump, these items must be removed from the original sump as they do not form part of Accessory Kit LP.

Illustration T424

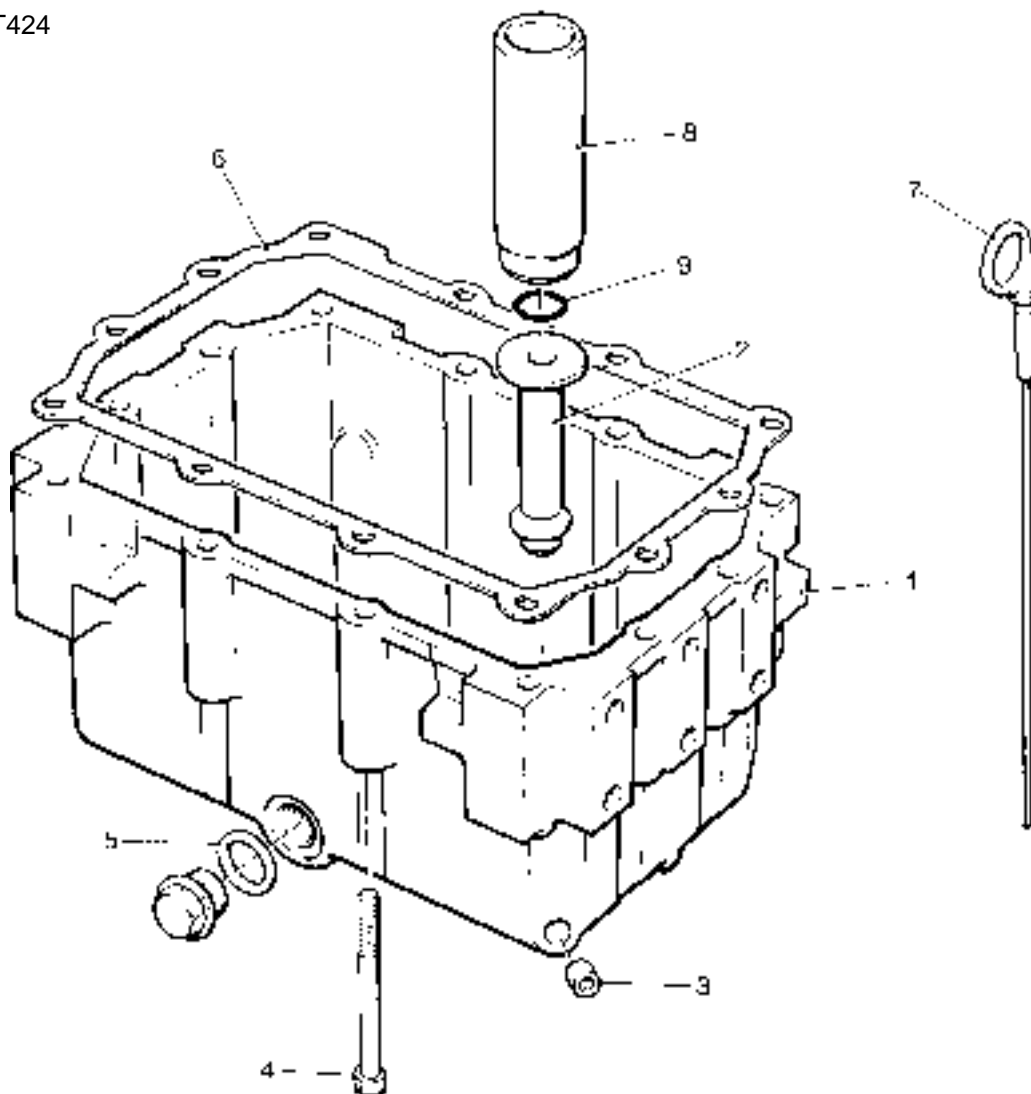

Sump with provision for Heater and Thermostat - TS/TR2, 3

Illustration T428
Description

Description	Part Number	TS/TR			Remarks
		1	2	3	
Accessory Kit Code LJ - TS/TR2	570-33540	-	1	-	See Note
Accessory Kit Code LJ - TS/TR3	570-33550	-	-	1	See Note
1 Sump Assembly - TS/TR2	570-33592	-	1	-	
- Sump Assembly - TS/TR3	570-33602	-	-	1	
2 Sump Joint - TS/TR2	202-30541	-	1	-	
- Sump Joint - TS/TR3	203-30542	-	-	1	
3 Taper Plug 1/2" BSP	027-00140	-	1	-	
4 Taper Plug 1" BSP	027-00142	-	1	-	
5 Copper Washer 1/2" BSP	013-21778	-	2	-	

Note:

The accessory kit must be factory or approved Lister-Peter Distributor fitted only.

Illustration T428

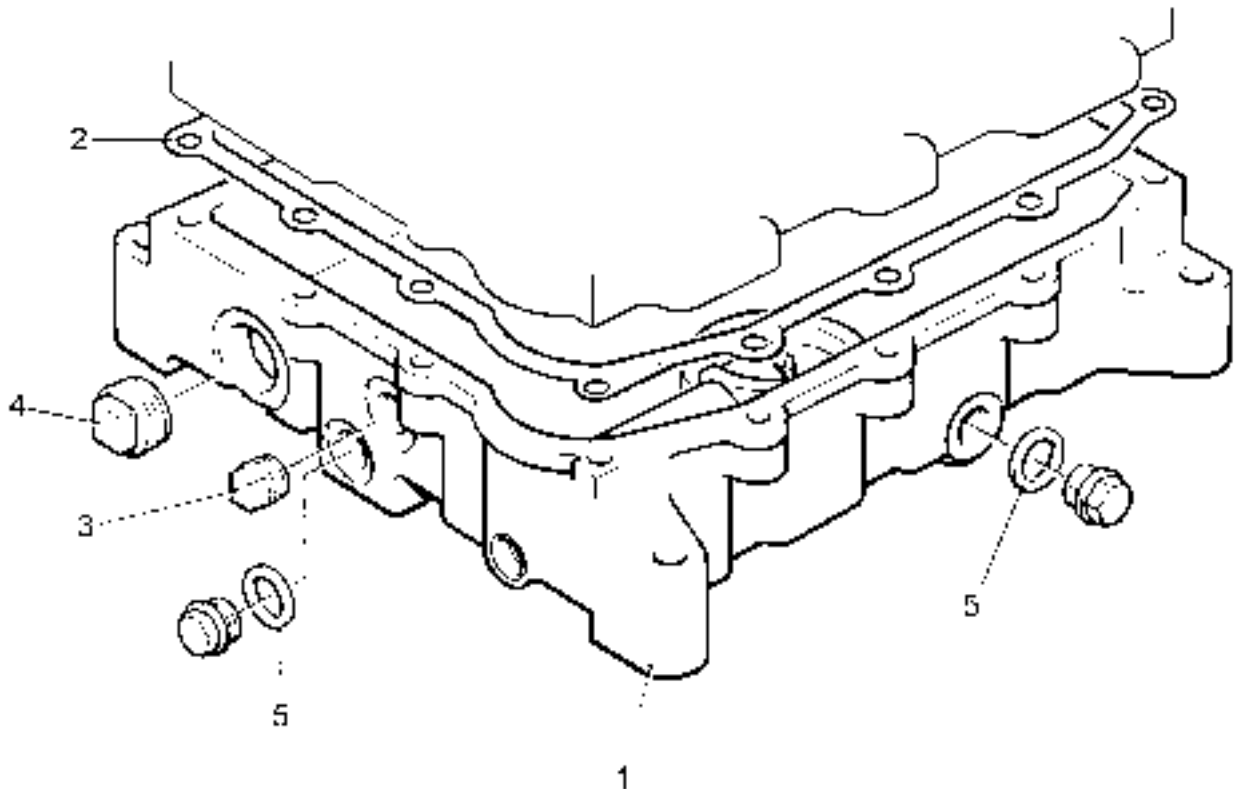

Oil Strainer, Pump and Filter

Illustration T11 No.	Description	Part Number	TS/TR			Remarks
			1	2	3	
1	Strainer Mesh	202-33740	1	1	1	
2	Cap Assembly	602-36820	1	1	1	
3	Setscrew - M8 x 14mm	272-00037	1	1	1	
4	Spring Washer	272-00071	1	1	1	
-	Oil Pump Assembly - TS/TR1	570-32670	1	-	-	
5	Oil Pump Assembly - TS/TR2,3	570-30680	-	1	1	
-	Oil Pump Assembly - TS/TR2,3	570-30681	-	1	1	Build 42
6	Cylinder	602-20610	1	1	1	
-	Seal - TS2,3	352-11911	-	1	1	Build 42
7	Lower Ball Valve	210-00393	1	1	1	
8	Retaining Plate	602-22150	1	1	1	
9	Spring - TS/TR1	602-37550	1	-	-	
-	Spring - TS/TR2,3	202-31055	-	1	1	
10	Plunger Washer	602-36340	1	1	1	
11	Plunger	602-20581	1	1	1	
12	Plunger Valve Seat Insert	602-36351	1	1	1	
13	Plunger Cap	602-20571	1	1	1	
14	Upper Ball Valve	202-32120	1	1	1	
15	Push Rod	203-45160	1	1	1	Replaces 203-31370
16	Oil Filter	201-55370	1	1	1	
17	Connector	201-36111	1	1	1	
-	Lubricating Oil Pipe - TS/TR1	201-41181	1	-	-	
18	Lubricating Oil Pipe - TS/TR2	202-31671	-	1	-	
-	Lubricating Oil PNew Pageipe - TS/TR3	203-31671	-	-	1	
19	Swivel Union Plug	202-34000	2	3	4	
20	Copper Washer	616-01608	4	6	8	
21	Clip	201-31411	2	2	2	
22	Adaptor	201-41710	1	-	-	
23	Copper Washer	616-01608	1	-	-	
24	Swivel Union Plug	601-30946	1	-	-	
25	Copper Washer	291-26090	2	-	-	

Illustration T11

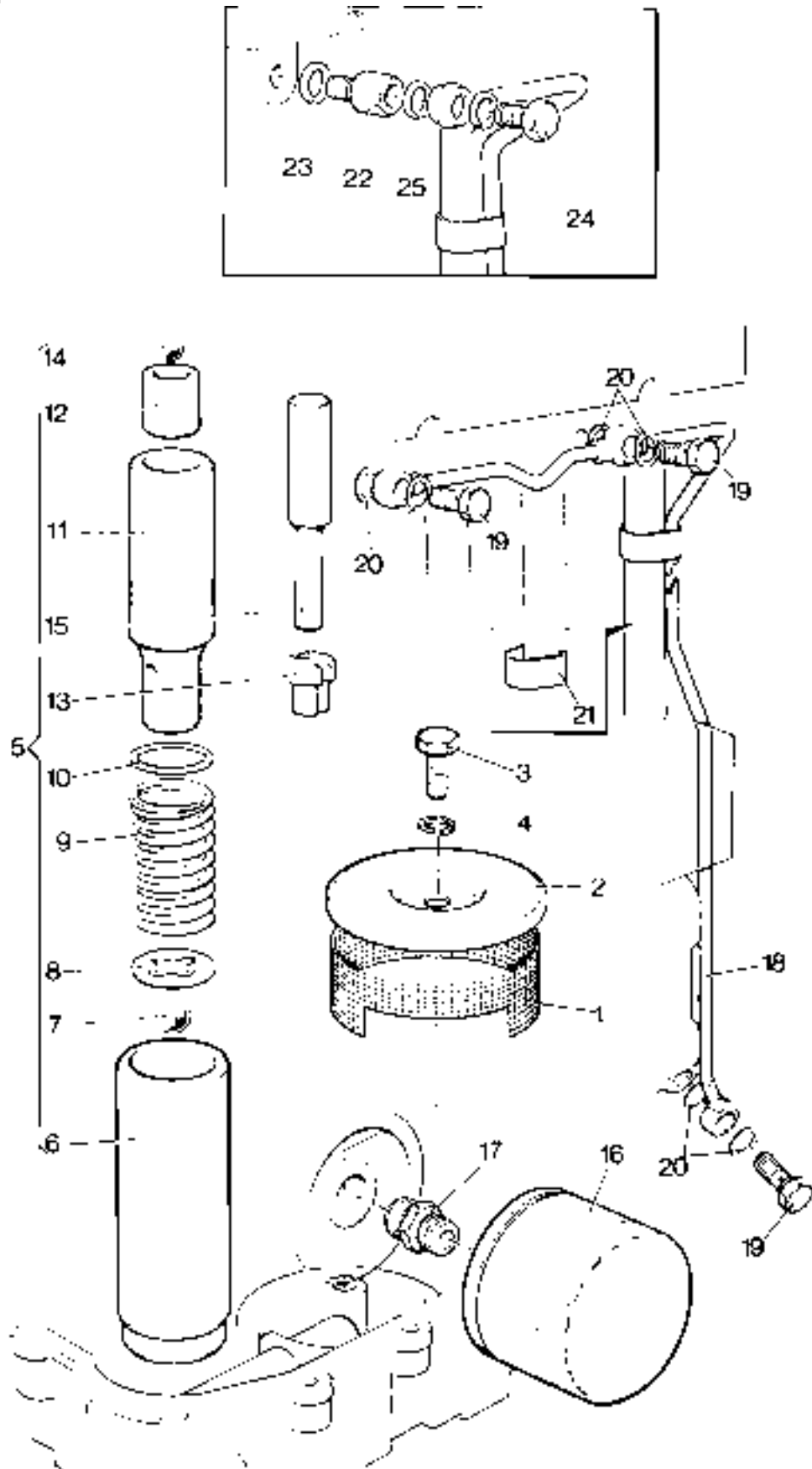

Remote Mounted Oil Filter

Illustration T217		TS/TR			Remarks	
No.	Description	Part Number	1	2		3
	Accessory Kit Code LB	570-31950	1	1	1	
1	Oil Filter Adaptor	367-34470	1	1	1	
2	Union	352-28760	4	4	4	
3	Copper Washer 1/4" BSP	013-22350	4	4	4	
4	Union Adaptor	366-06930	1	1	1	
5	'O' Ring Seal	351-10341	2	2	2	
6	Remote Oil Filter Adaptor	367-34480	1	1	1	
7	'O' Ring Seal	201-41970	1	1	1	
8	Oil Filter	201-55370	1	1	1	
9	Pipe Union	201-55360	1	1	1	
10	Nut	272-00004	1	1	1	

Illustration T217

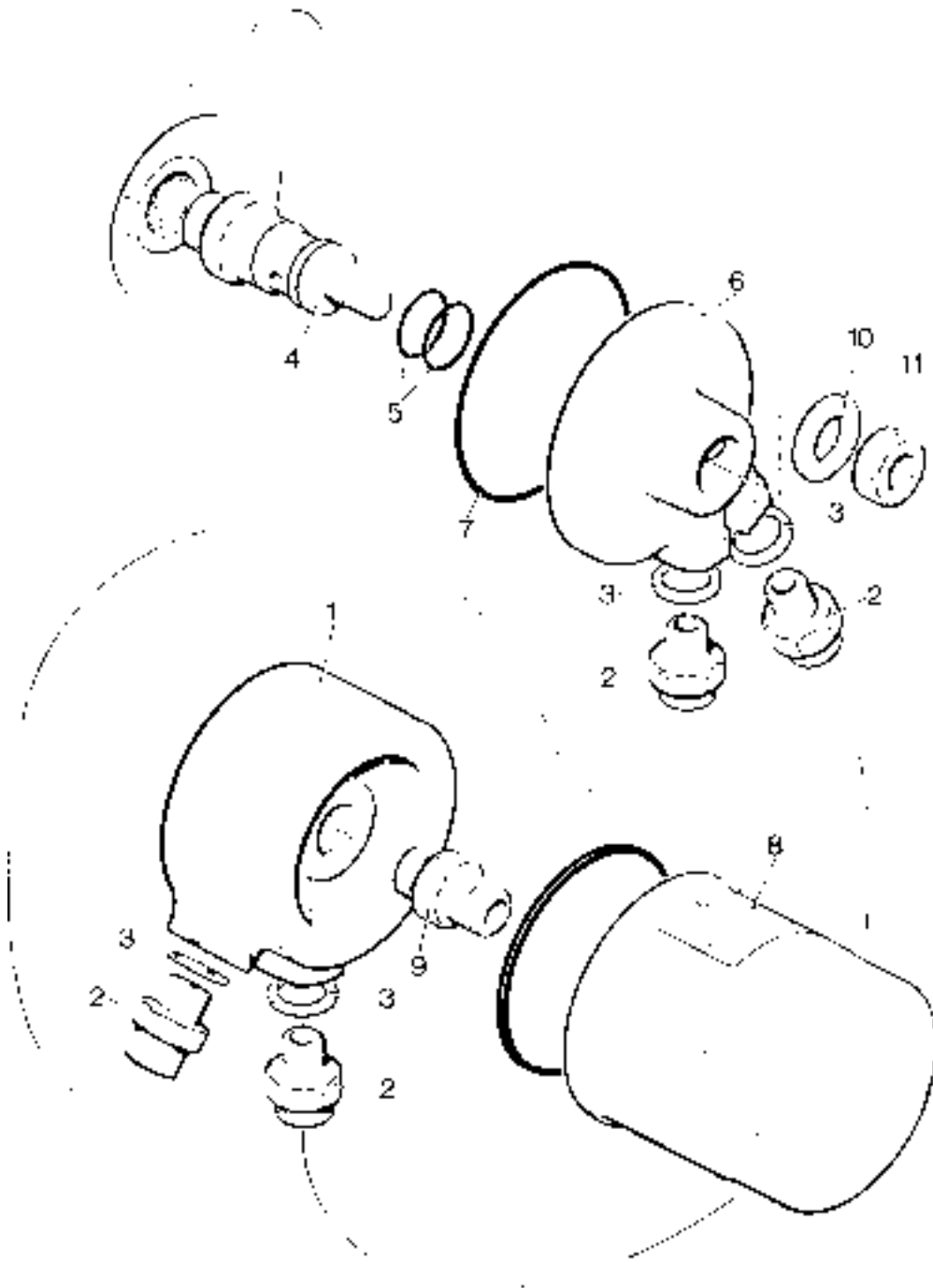

Crankshaft, Connecting Rod, Piston and Cylinder Barrel

Illustration T173 No. Description	Part Number	TS/TR			Remarks
		1	2	3	
Cylinder barrels are only available as a kit complete with piston.					
- Crankshaft Assembly - TS1	570-30403	1	-	-	See Note ¹
- Crankshaft Assembly - TS2	570-30033	-	1	-	See Note ¹
- Crankshaft Assembly - TS3	570-30143	-	-	1	See Note ¹
- Crankshaft Assembly - TR1	570-31042	1	-	-	
1 Crankshaft Assembly - TR2	570-30223	-	1	-	
- Crankshaft Assembly - TR3	570-30233	-	-	1	
2 Expansion Plug - TS	201-46820	1	2	3	Replaces rivet 027-06890
- Expansion Plug - TR	351-40190	1	2	3	See Note ²
3 Balance Weight	201-30362	2	4	4	See Note ³ Not used on Build 07
- Balance Weight	201-30363	2	4	4	Build 07
4 Cap Screw	272-00353	4	8	8	
5 Pinion	201-37660	1	1	1	
6 Key	027-00352	1	1	1	
- Thrust Washer Assembly	570-31360	2	2	2	
7 Top Half		2	2	2	
7a Bottom Half		2	2	2	
- Connecting Rod Assembly	570-30261	1	2	3	
8 Connecting Rod		1	2	3	
9 Bolt	201-80300	2	4	6	
10 Nut - 3/8" UNF	270-00778	2	4	6	
11 Small End Bush	201-44950	1	2	3	
- Big End Bearing Assembly	570-31370	1	2	3	
12 Top Half		1	2	3	
12a Bottom Half		1	2	3	
- Piston Assembly - TS (5 Ring)	570-12840	1	2	3	Not Builds 41, 60-66
- Piston Assembly - TS (3 Ring)	570-33470	1	2	3	Builds 41, 60-66
13 Piston Assembly - TR (3 Ring)	570-33360	1	2	3	
- Piston Ring Set - TS (5 Ring)	570-12910	1	2	3	Not Builds 41, 60-66
- Piston Ring Set - TS (3 Ring)	570-33480	1	2	3	Builds 41, 60-66
- Piston Ring Set - TR (3 Ring)	570-33370	1	2	3	
14 Gudgeon Pin		1	2	3	
15 Circlip	201-80420	2	4	6	
16 Cylinder Barrel/Piston Kit - TS	570-35540	1	2	3	See Note ⁴
- Cylinder Barrel/Piston Kit - TS	570-37430	1	2	3	Builds 41 & 60-66. See Note ⁴
- Cylinder Barrel/Piston Kit - TS	570-37430	-	2	3	Build 104. See Note ⁴
- Cylinder Barrel/Piston Kit - TR	570-35530	1	2	3	See Note ⁵
17 Joint	201-32430	1	1	1	

Notes:

- Up to the following engine numbers flywheels were secured with a Retaining Setscrew 201-30340.
Nut 202-33790 and Washer 202-33800 will be required with crankshafts after these engine numbers.
3500630TS1 3506716TS2 3505963TS3
3600255TR1 3600073TR2 3600112TR3
- The plug was first fitted on the following TS engines:
4300920TS1 4302489TS2 4301742TS3
- Early crankshaft balance weights were fitted with a single capscrew.
If an early crankshaft is being replaced it will be necessary to fit the later two hole fixing balance weights.
2 Bolt Balance Weights introduced on Engine numbers:
3405892TS2 3406086TS3
To replace Crankshafts/Balance Weights on earlier engines supply items 1, 3 and 4 above.
- TS Cylinder Barrel/Piston Kit comprises 201-37700 and 570-12840.
For builds 41 & 60-66 kit comprises 201-37700 and 570-33470.
For build 104 kit comprises 201-32430 and 570-30701.
- TR Cylinder Barrel/Piston Kit comprises 201-32804 and 570-33360.
(201-32804 replaces 201-32802).

Illustration T173

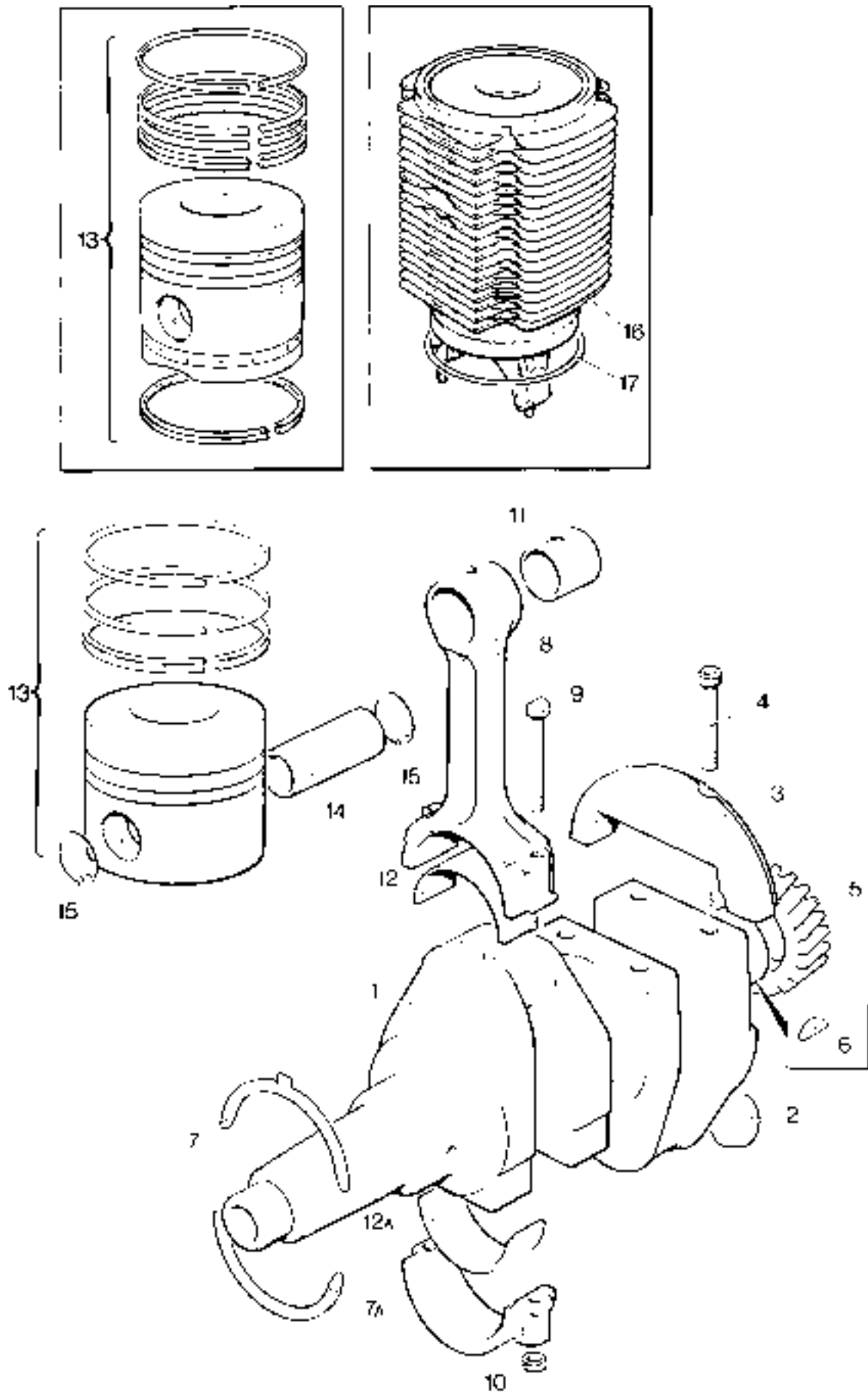

Main Bearing Housing

Illustration T1

No.	Description	Part Number	TS/TR			Remarks
			1	2	3	
1	Main Bearing Housing Assembly	570-30602	1	1	1	Replaces 570-30601
-	Main Bearing Housing Assembly	570-30603	1	1	1	For charge winding builds
2	Main Bearing - Standard	570-30011	1	1	1	
-	Main Bearing - 0,25mm undersize	570-30011/025	1	1	1	
-	Main Bearing - 0,50mm undersize	570-30011/050	1	1	1	
-	Main Bearing - 0,75mm undersize	570-30011/075	1	1	1	
-	Main Bearing - 1,00mm undersize	570-30011/100	1	1	1	
3	Lip Seal	201-41940	1	1	1	
4	Setscrew - M8 x 20mm	272-00039	6	6	6	
5	Spring Washer	272-00071	6	6	6	
6	Shim - 0,127mm (0,005")	201-30943				Use as required
7	Shim - 0,254mm (0,010")	201-30944				Use as required
8	'O' Ring Seal	201-45920	1	1	1	Replaces 601-37420
9	Setscrew - M8 x 20mm	272-00727	2	2	2	Not used on TR1 Build 100
-	Setscrew - M8 x 10mm	272-00239	2	-	-	Only used on TR1 Build 100
10	Copper Washer	616-01608	2	2	2	

Note:

For further reference to Main Bearings see 'Crankcase' section.

Illustration T1

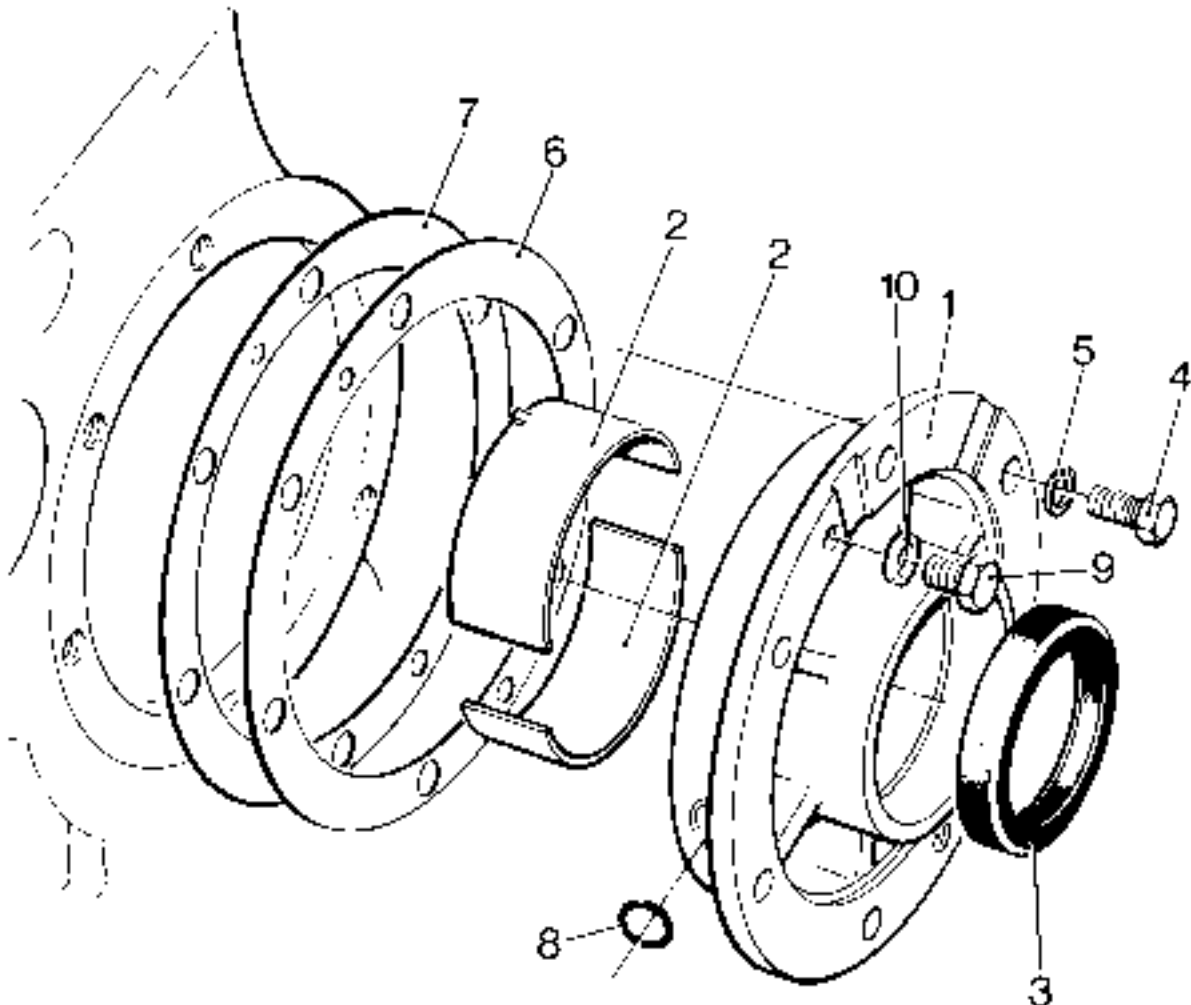

Centre Bearing Housing

Illustration T327
No. Description

TS/TR
Part Number 1 2 3 Remarks

-	Centre Bearing Housing Assembly	202-80591	-	1	2	
1	Top Half Bearing Housing		-	1	2	
2	Bottom half Bearing Housing		-	1	2	
3	Spring Dowel Bush	751-18290	-	2	4	Replaces Dowel 010-02110
4	Cap Screw - M8 x 50mm	272-00261	-	2	4	
5	Centre Bearing - Standard	570-12990	-	1	2	
-	Centre Bearing - 0,010in undersize	570-12990/010	-	1	2	
-	Centre Bearing - 0,020in undersize	570-12990/020	-	1	2	
-	Centre Bearing - 0,030in undersize	570-12990/030	-	1	2	
-	Centre Bearing - 0,040in undersize	570-12990/040	-	1	2	
6	Locating Dowel	202-31090	-	1	2	Fitted into position 'X' as shown in the Crankcase Illustration T5
7	Plug Assembly	202-31100	-	1	2	
8	Copper Washer	600-00106	-	1	2	

Illustration T327

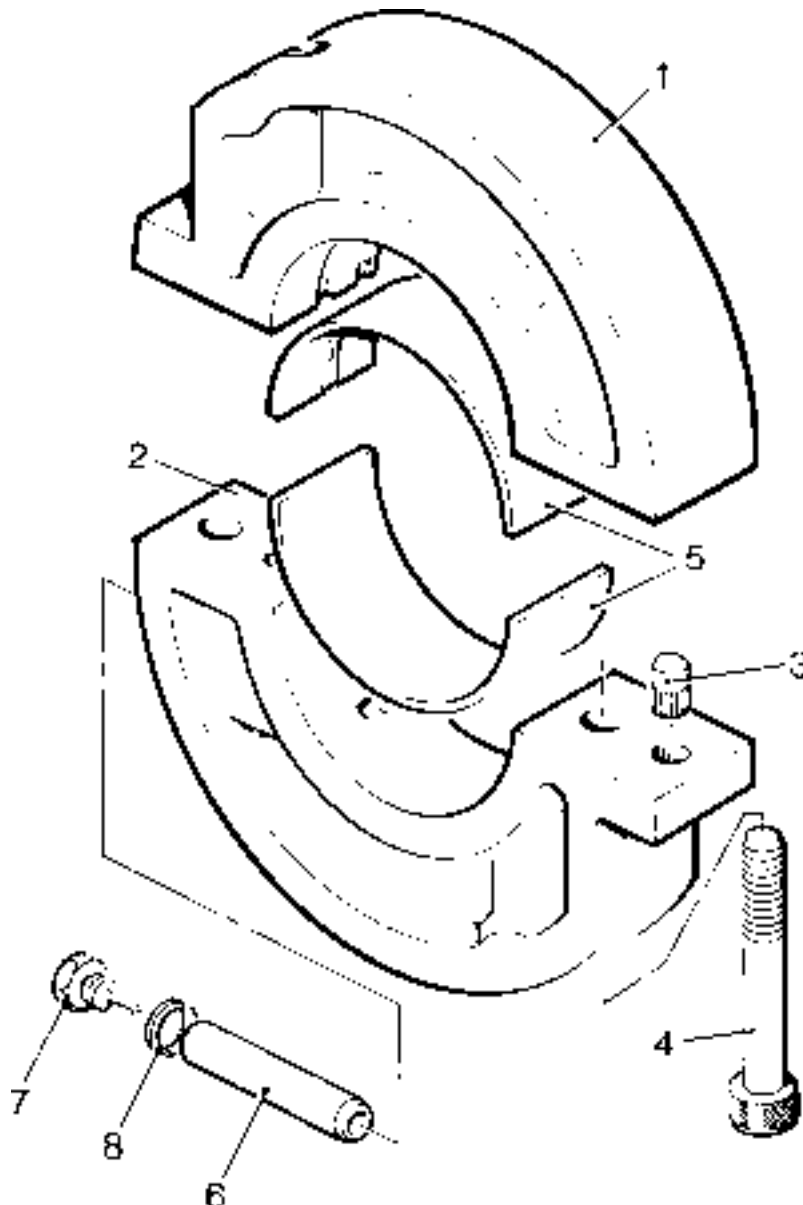

Camshaft and Governor - Early Engines

Notes:

There have been alterations to the governor assembly and the two types are not totally interchangeable.

A one-piece 'Nylatron' sleeve has been introduced to replace the original sleeve assembly.

The Nylatron sleeve is interchangeable with the older assembly if the:

- Governor lever shoes are removed,
- Governor weight shoes are removed,
- Governor sleeve setting 'A' is set at 9,5mm (refer to the Workshop Manual).

Re-designed pivot blocks and return springs are now fitted with the springs not being interchangeable, if the pivot blocks are changed the return springs must also be changed.

All of the above changes were introduced on the following engines:

35 01614 TS1	36 00001 TR1
35 07495 TS2	36 00011 TR2
35 06047 TS3	36 00141 TR3

From the above engines refer to 'Camshaft and Governor - Later Engines'

Illustration T157 No.	Description	Part Number	TS/TR			Remarks
			1	2	3	
-	Camshaft Assembly - TS/TR1	570-31210	1	-	-	
-	Camshaft Assembly - TS/TR2	570-30611	-	1	-	
-	Camshaft Assembly - TS/TR3	570-30641	-	-	1	
1	Camshaft - TS/TR2		-	1	-	
2	Gearwheel	202-38000	1	1	1	Replaces 201-37650
3	Dowel Pin	601-31100	1	1	1	
4	Key	027-00441	1	1	1	
5	Ball Bearing	201-30670	1	1	1	
6	Governor Weight Assembly					See 'Governor Weights and Speeder Springs' section
7	Shoe	351-34850	2	2	2	
8	Pin	201-10721	2	2	2	
9	Retainer	202-37990	4	4	4	
10	Setscrew - M6 x 16mm	272-00034	4	4	4	
11	Spring Washer	272-00070	4	4	4	
12	Catch Pin	201-43040	1	1	1	
13	Spring Pin	027-05516	1	1	1	
14	Thrust Washer	201-30390	2	2	2	
15	Thrust Pad	201-30410	1	1	1	
16	Spring Ring	201-30400	1	1	1	
17	Governor Sleeve	201-42900	1	1	1	Replaces 201-30370
18	Governor Lever Assembly	201-31160	1	1	1	
19	Pivot Block	201-31141	2	2	2	Replaces 201-31140
20	Pin	601-20910	2	2	2	
21	Shim	601-22330				Use as required
22	Shoe	601-33220	2	2	2	
23	Return Spring	201-31312	1	1	1	Variable speed engines only
24	Shim - 0,13mm	201-30680				Use as required
-	Shim - 0,25mm	201-30681				Use as required
-	Shim - 0,38mm	201-30682				Use as required
25	Thrust Washer	201-30420	1	1	1	

Illustration T157

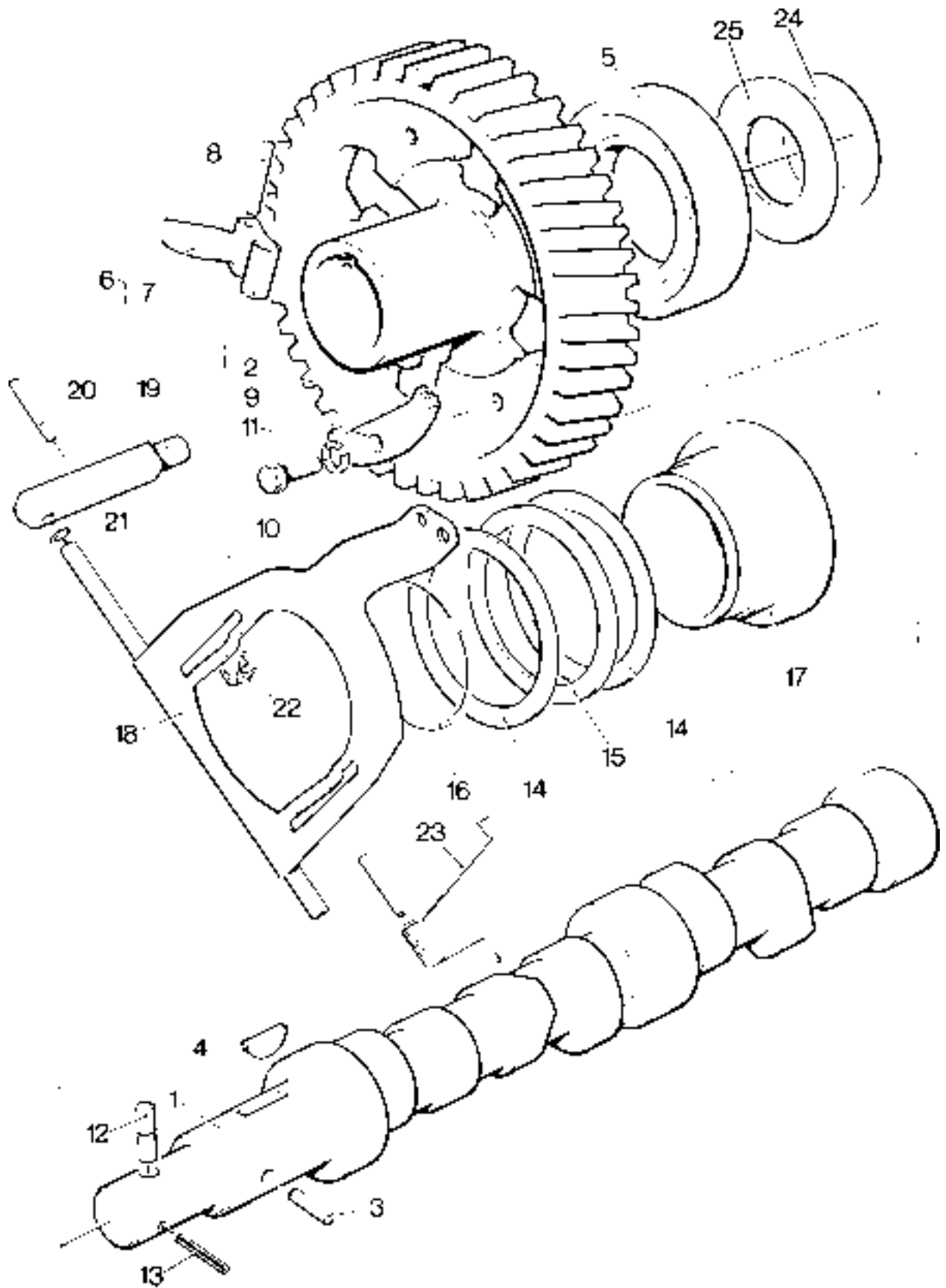

Camshaft and Governor - Later Engines

Note:

On engine numbers below those shown refer to 'Camshaft and Governor - Early Engines'

3501614TS1	3600001TR1
3507495TS2	3600011TR2
3506047TS3	3600141TR3

Illustration No.	Description	Part Number	TS/TR			Remarks
			1	2	3	
-	Camshaft Assembly - TS/TR1	570-31032	1	-	-	
-	Camshaft Assembly - TS1	570-31200	1	-	-	Build 101
-	Camshaft Assembly - TS/TR2	570-30275	-	1	-	
-	Camshaft Assembly - TS2	570-30821	-	1	-	Build 104
-	Camshaft Assembly - TR2	570-30631	-	1	-	Build 101
-	Camshaft Assembly - TS/TR3	570-30285	-	-	1	
-	Camshaft Assembly - TS3	570-30851	-	-	1	Build 104
1	Camshaft		-	1	-	
2	Gearwheel	202-38000	1	1	1	
3	Dowel Pin	601-31100	1	1	1	
4	Key	027-00441	1	1	1	
5	Ball Bearing	201-30670	1	1	1	
6	Governor Weight Assembly					See 'Governor Weights and Speeder Springs' section
7	Pin	201-10721	2	2	2	
8	Retainer	202-37990	4	4	4	
9	Setscrew - M6 x 16mm	272-00034	4	4	4	
10	Spring Washer	272-00070	4	4	4	
11	Catch Pin	201-43040	1	1	1	
12	Grub Screw	272-00603	1	1	1	
13	Governor Sleeve	201-42900	1	1	1	
14	Governor Lever Assembly	201-31160	1	1	1	
15	Pivot Block	201-31141	2	2	2	
16	Pin	601-20910	2	2	2	
17	Shim	601-22330				Use as required - see Note.
18	Return Spring	201-31312	1	1	1	Variable speed engines only

Note:

The shims are fitted to achieve an endfloat of 0.12-0.25mm

Illustration T157C

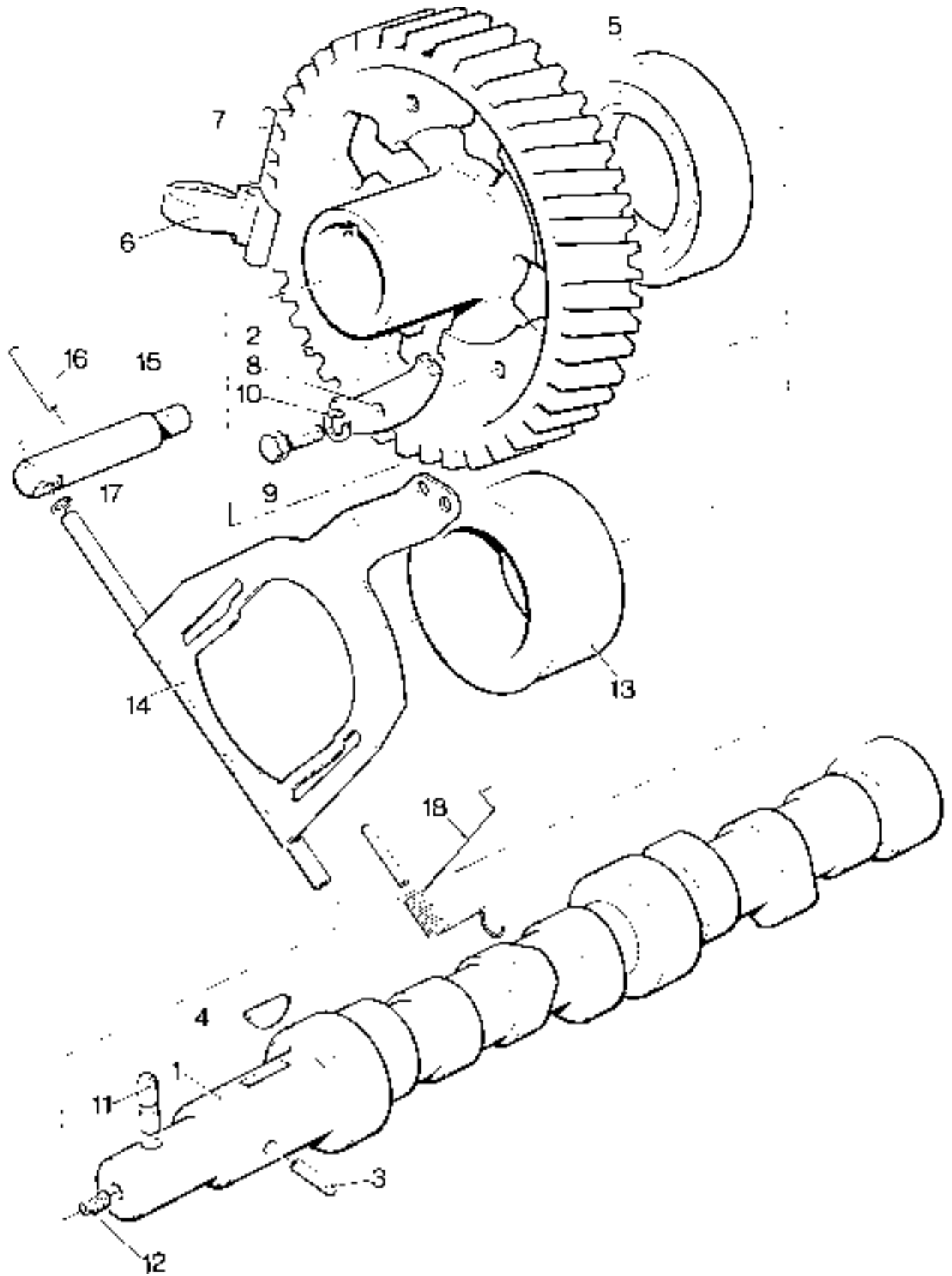

Fuel Pump Linkage and Engine Controls

Illustration T126 No. Description	Part Number	TS/TR			Remarks
		1	2	3	
1 Governor Link Assembly	202-39430	1	1	1	Replaces 202-36950
2 Fuel Pump Link Assembly	202-42070	-	1	2	Replaces 202-32300, 203-32370, 203-32410
- Governor Link	202-39180	-	1	2	
3 Connector	202-39190	-	1	2	
4 Shackle	202-39170	-	1	2	
5 Retaining Link	601-38490	-	1	2	
6 Retaining Spring	202-39200	-	1	2	
7 Governor Lever Spring	201-31340	1	1	1	
8 Nut	272-00001	4	4	4	
9 Swivel Spacer	601-21000	2	2	2	
- Speed Control Lever Assembly - TS/TR1	201-39742	1	-	-	Replaces 201-39741 when Bracket 202-34193 is supplied
10 Speed Control Lever Assembly - TS/TR2,3	202-34233	-	1	1	Replaces 202-34232 when Bracket 202-34193 is supplied
11 Bracket - TS/TR2,3	202-34193	1	1	1	Replaces 202-34192
12 'O' Ring	201-13120	1	1	1	
13 Pin	201-31240	1	1	1	
- Setscrew - M6 x 14mm - TS/TR1	272-00034	1	-	-	Replaces 272-00033
14 Setscrew - M6 x 12mm - TS/TR2,3	272-00120	-	1	1	
15 Spring Washer	272-00070	1	1	1	
16 Adjusting Screw - M6 x 35mm	272-00349	1	1	1	
17 Adjusting Screw - M6 x 45mm	272-00387	1	1	1	
18 Nut	272-00351	2	2	2	
19 Adjusting Screw		1	1	1	See 'Governor Weights and Speeder Springs' section
20 Speeder Spring					See 'Governor Weights and Speeder Springs' section
21 Spindle Assembly	201-42530	1	1	1	
22 Location Plate	201-31381	1	1	1	
23 Tamperproof Setscrew	201-46630	1	1	1	
23a Setscrew - M6 x 12mm	272-00032	1	1	1	
24 Spring Washer	272-00070	1	1	1	
25 Washer	027-00618	1	1	1	
26 'O' Ring	201-13120	1	1	1	
27 Stop Control Spring	601-35490	1	1	1	
- Lever Assembly	570-33430	1	1	1	
28 Lever	201-31270	1	1	1	
29 Cam	201-31280	1	1	1	
30 Automatic Excess Fuel Spring	201-31350	1	1	1	
31 Pin	601-40370	1	1	1	Replaces 382-03233
32 Spring	202-37600	1	1	1	
33 Dowel	601-35370	1	1	1	
34 Stop Control Knob	201-37291	1	1	1	
35 Screw - M4 x 10mm	272-00061	2	2	2	
36 Spring Washer	272-00084	2	2	2	
37 Washer	064-06612/004	2	2	2	
- Capscrew - M4 x 80mm	272-00381	1	1	-	Builds 101, 102

Illustration T126

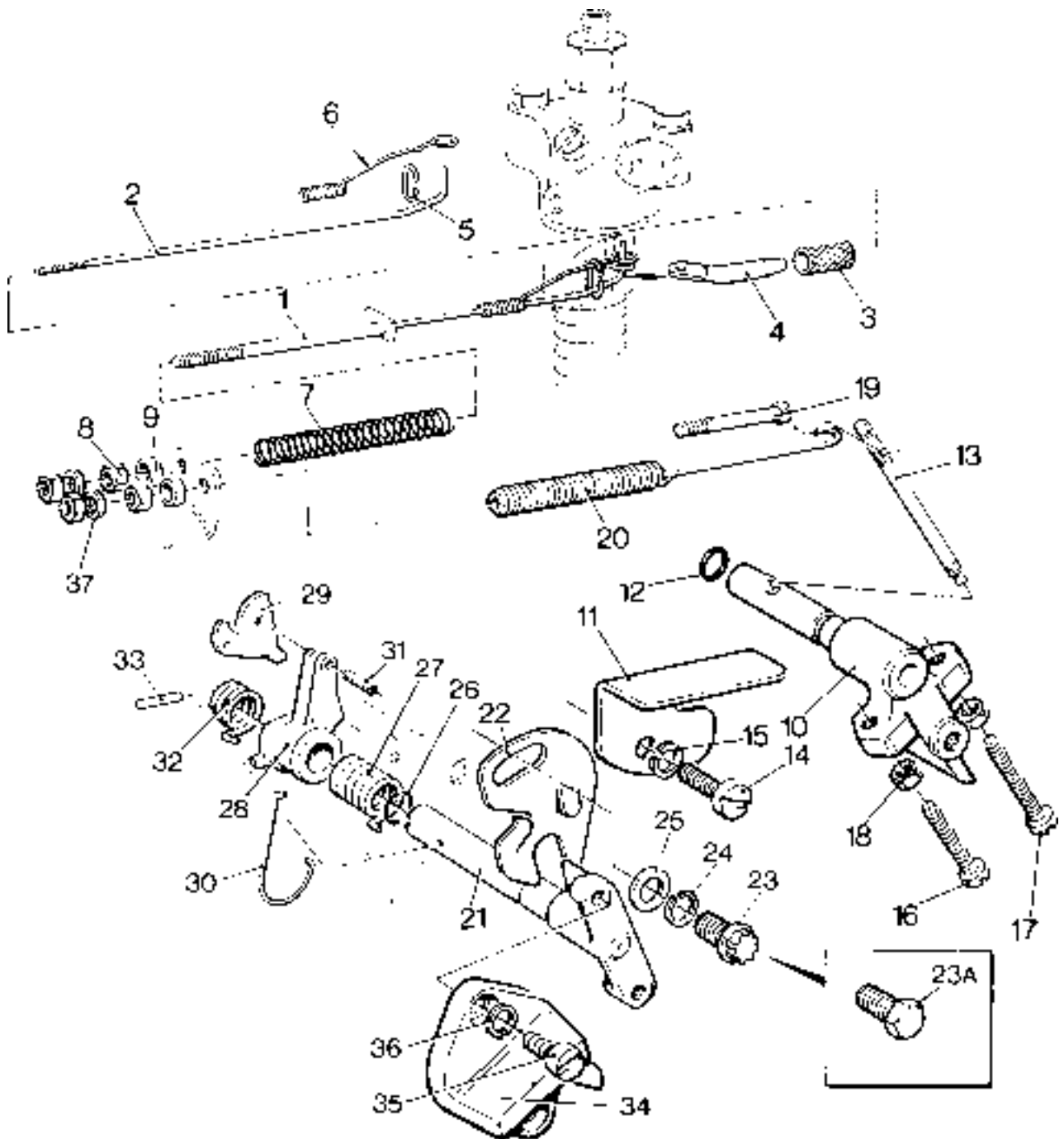

Governor Weights and Speeder Springs - TS

TS1 Build	Governor Weights	Weights			Speeder Spring	Spring Colour Code	Adjusting Screw	Inner Spring
		Qty.	Code	Early				
01 - 07	351-35910	2	Q	(18)*	201-31364	White	272-00620	-
08 - 11	351-35860	4	L	(13)*	201-31364	White	272-00381	201-41980
12, 13	351-35930	2	S	(20)*	201-31361	Yellow	272-00173	-
14, 15	351-35910	2	Q	(18)*	201-31364	White	272-00620	-
16	351-35860	2	L		201-31364	White	272-00620	-
17	351-35910	2	Q	(18)*	201-31364	White	272-00620	-
18	351-35860	2	L		201-31364	White	272-00620	-
40 - 61	351-35910	2	Q		201-31364	White	272-00620	-
62 - 65	351-35860	4	L		201-31364	White	272-00381	201-41980
66	351-35910	2	Q		201-31364	White	272-00620	-
78, 101	351-35860	4	L		201-31364	White	272-00381	201-41980
102, 104	351-35910	2	Q		201-31364	White	272-00620	-

* See Note below

TS2, 3 Build	Governor Weights	Weights			Speeder Spring	Spring Colour Code	Adjusting Screw	Inner Spring
		Qty.	Code	Early				
01 - 07	351-35910	2	Q	(18)*	201-31364	White	272-00620	-
08 - 11	351-35860	4	L	(13)*	201-31364	White	272-00381	201-41980
12, 13	351-35930	2	S	(13)*	201-31361	Yellow	272-00344	-
14 - 40	351-35910	2	Q		201-31364	White	272-00620	-
41	351-35860	2	L		201-31364	White	272-00620	-
42	351-35910	2	Q		201-31364	White	272-00620	-
43	351-35860	4	L		201-31364	White	272-00381	201-41980
50 - 61	351-35910	2	Q		201-31364	White	272-00620	-
62 - 65	351-35860	4	L		201-31364	White	272-00381	201-41980
66	351-35910	2	Q		201-31364	White	272-00620	-
78, 101	351-35860	4	L		201-31364	White	272-00381	201-41980
104	351-35910	2	Q		201-31364	White	272-00620	-

* Note:

The codes in brackets are for early engines, refer to 'Camshaft and Governor - Early Engines'.

Governor Weights and Speeder Springs - TR

TR1 Build	Governor Weights	Weights			Speeder Spring	Spring Colour Code	Adjusting Screw	Inner Spring
		Qty.	Code	Early				
01 - 07	351-35910	2	Q	(18)*	201-31364	White	272-00620	-
08 - 11	351-35860	4	L	(13)*	201-31364	White	272-00381	201-41980
14 - 16	351-35910	2	Q	(18)*	201-31364	White	272-00620	-
78	351-35860	4	L		201-31364	White	272-00381	201-41980
100	351-35910	2	Q		201-31364	White	272-00620	-

* See Note below

TR2, 3 Build	Governor Weights	Weights			Speeder Spring	Spring Colour Code	Adjusting Screw	Inner Spring
		Qty.	Code	Early				
01 - 07	351-35910	2	Q	(18)*	201-31364	White	272-00620	-
08 - 11	351-35860	4	L	(13)*	201-31364	White	272-00381	201-41980
12, 13	351-35930	2	S	(13)*	201-31361	Yellow	272-00344	-
14 - 40	351-35910	2	Q		201-31364	White	272-00620	-
41	351-35860	2	L		201-31364	White	272-00620	-
42	351-35910	2	Q		201-31364	White	272-00620	-
43	351-35860	4	L		201-31364	White	272-00381	201-41980
50 - 61	351-35910	2	Q		201-31364	White	272-00620	-
62 - 65	351-35860	4	L		201-31364	White	272-00381	201-41980
66	351-35910	2	Q		201-31364	White	272-00620	-
78, 101	351-35860	4	L		201-31364	White	272-00381	201-41980
104	351-35910	2	Q		201-31364	White	272-00620	-

* Note:

The codes in brackets are for early engines, refer to 'Camshaft and Governor - Early Engines'.

Gear End Cover

Not used on Builds 05, 06, 07, 40

Illustration T2

No.	Description	Part Number	TS/TR			Remarks
			1	2	3	
1	End Cover Assembly	201-47980	1	1	1	Replaces 201-33851
	Accessory Kit Code EY	570-72411	1	1	1	Replaces 570-72410. Non-hand-start End Cover Assembly. See Note
1a	Bush	601-39740	1	1	1	
2	Oil Filler	027-06317	1	1	1	
3	Strainer Plate	291-23751	1	1	1	
-	Protective Cap	027-07917	1	1	1	Included in Code EY
4	Joint	201-33011	1	1	1	
5	Oil Filler Cap	366-08126	1	1	1	Replaces 027-03824/366-00091
-	Oil Filler Cap Joint	303-00253	1	1	1	
6	Bolt - M8 x 70mm	272-00179	7	7	7	
7	Washer	027-00082	7	7	7	
8	Dowel	351-13660	2	2	2	
9	Camshaft Oil Seal	601-39550	1	1	1	
10	Cap	351-36580	1	1	1	
11	Camshaft Thrust Washer	201-30420	1	1	1	
12	Shim - 0.13mm	201-30680				Use as required
-	Shim - 0.25mm	201-30681				Use as required
-	Shim - 0.38mm	201-30682				Use as required
-	Shim - 0.50mm	201-30683				Use as required
-	Shim - 0.63mm	201-30684				Use as required

Note:

When fitting Non hand start End Cover Assembly, Catch Pin (201-43040) and Spring Pin (027-05516) must be removed from Camshaft.

Illustration T2

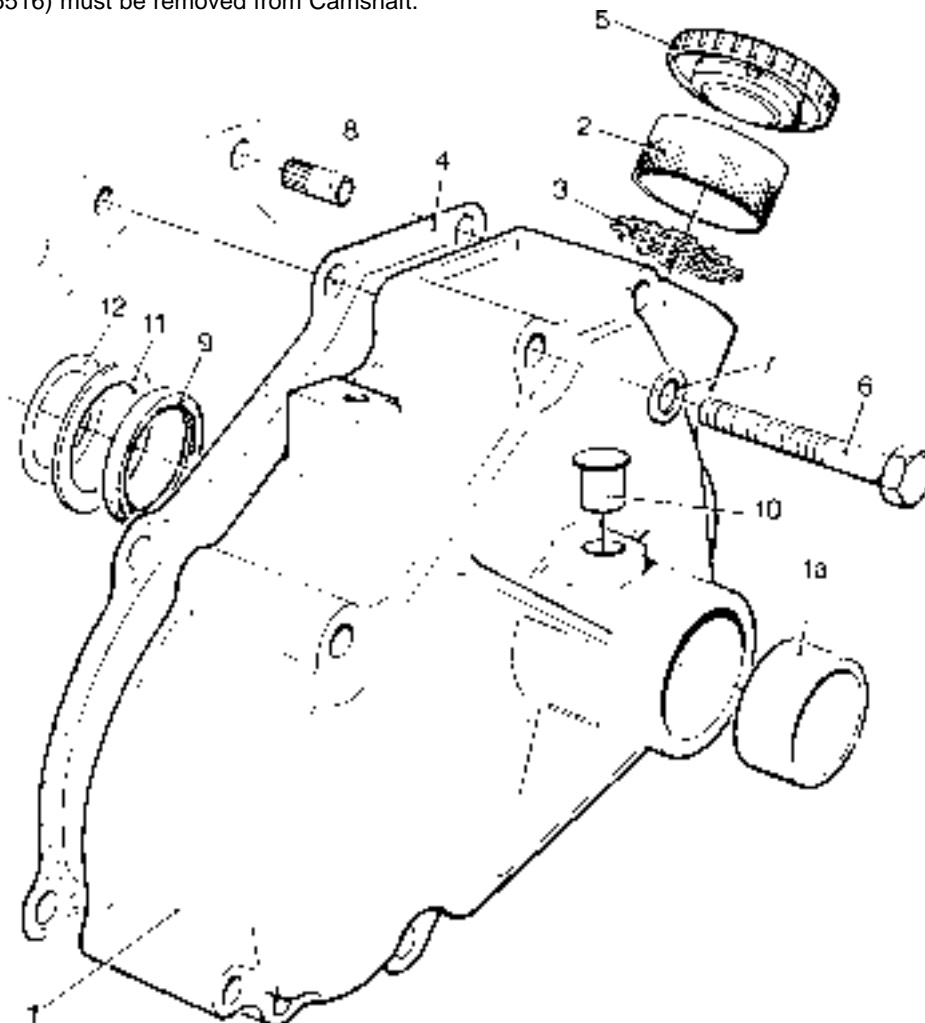

Gear End Cover - Builds 05 and 104

Illustration T131
No. Description

TS/TR
1 2 3 Remarks

No.	Description	Part Number	1	2	3	Remarks
1	End Cover Assembly	570-30061	-	1	1	
2	Oil Filler	027-06317	-	1	1	
3	Strainer Plate	291-23751	-	1	1	
4	Joint	201-33012	-	1	1	
5	Oil Seal	201-32740	-	1	1	
6	Oil Filler Cap	027-03824	-	1	1	Build 05
-	Oil Filler Cap	366-08126	-	1	1	Build 104
-	Oil Filler Cap Joint	303-00253	-	1	1	
7	Bolt - M8 x 70mm	272-00179	-	7	7	
8	Washer	027-00082	-	7	7	
9	Dowel	351-13660	-	2	2	
10	Camshaft Thrust Washer	201-30420	-	1	1	
11	Shim - 0.13mm	201-30680	-			Use as required
-	Shim - 0.25mm	201-30681	-			Use as required
-	Shim - 0.38mm	201-30682	-			Use as required
-	Shim - 0.50mm	201-30683	-			Use as required
-	Shim - 0.63mm	201-30684	-			Use as required
12	Setscrew	270-00350	-	1	1	
13	Washer	201-11890	-	2	2	

Illustration T131

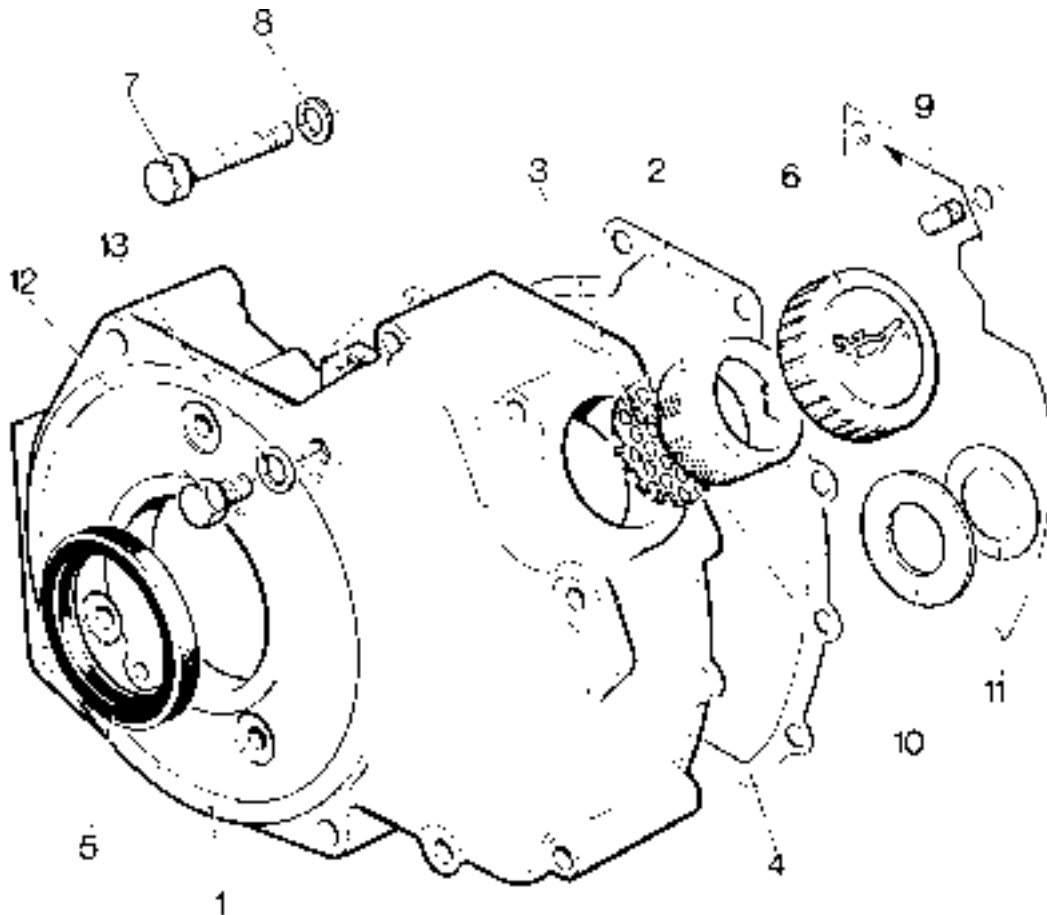

Gear End Cover - Builds 06, 07

Illustration T25 No.	Description	Part Number	TS/TR			Remarks
			1	2	3	
1	End Cover Assembly - TS/TR2,3.....	201-47983	1	1	1	Replaces 570-30101, 570-31070
2	Oil Filler	027-06317	1	1	1	
3	Strainer	291-23751	1	1	1	
4	Bush	601-39740	2	2	2	
5	Oil Filler Cap.....	366-08126	1	1	1	
-	Oil Filler Cap Joint	303-00253	1	1	1	
6	Joint.....	201-33012	1	1	1	
7	Bolt - M8 x 70mm	272-00179	6	6	6	
8	Bolt - M8 x 50mm	272-00044	1	1	1	
9	Washer	027-00082	7	7	7	
10	Bolt - 7/16"UNC x 3 3/4"	270-00756	1	1	1	
11	Bolt - 7/16"UNC x 3"	270-00777	1	1	1	
12	Washer	201-11890	2	2	2	
13	Dowel	351-13660	2	2	2	
14	Oil Seal	601-39550	1	1	1	
15	Plug	351-36580	1	1	1	
16	Pump Gear Assembly	570-30293	1	1	1	See Note
17	Stud.....	201-31930	1	1	1	

Note:

Comprises Pump Gear (201-31913) and Drive Pinion (201-31903). It is recommended that these items be fitted as a matched pair. See also Accessory Kits HF and HI.

Illustration T25

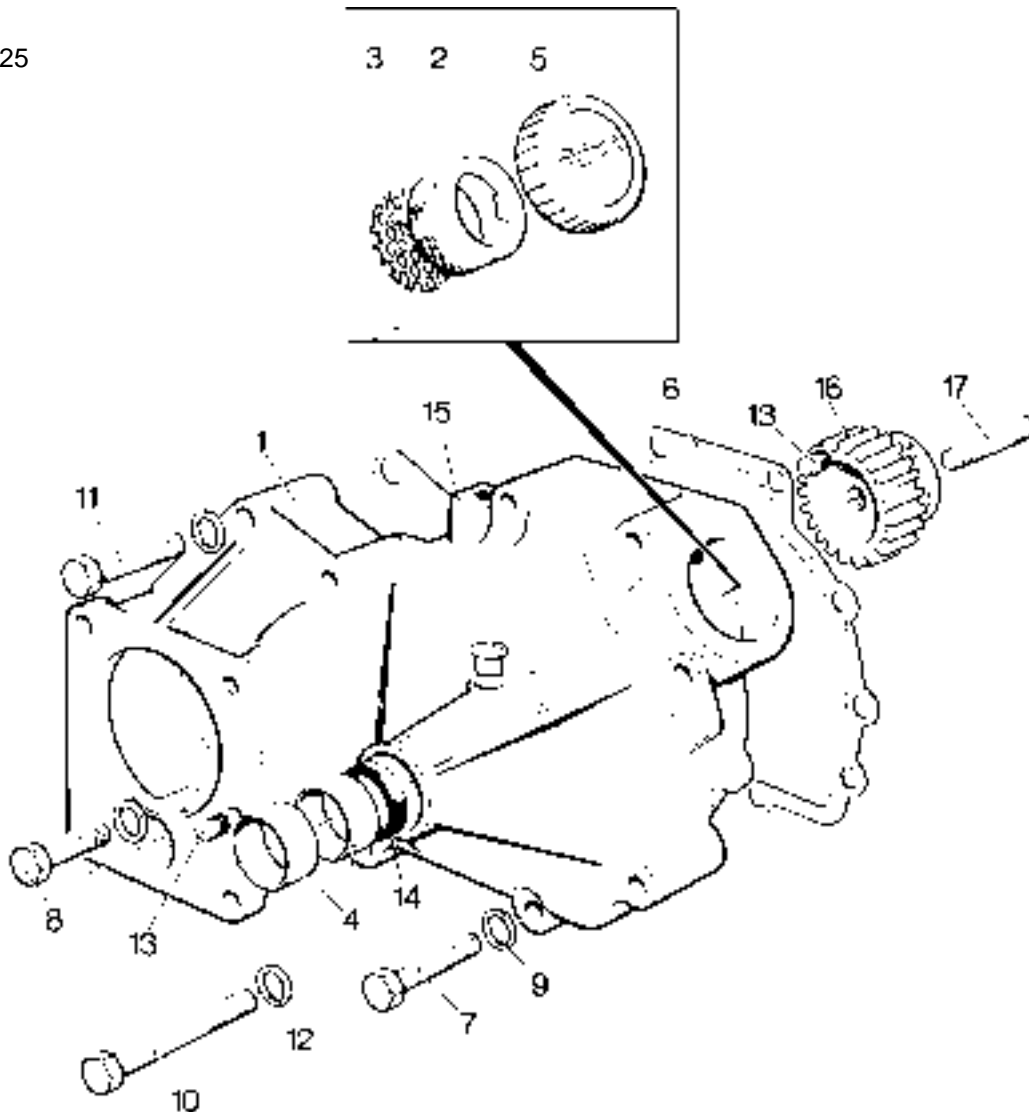

Gear End Cover - Build 40

Illustration T391
No. Description

Part Number TS/TR
1 2 3 Remarks

No.	Description	Part Number	TS	TR	Remarks
1	End Cover Assembly	201-47981	1	1	1 Replaces 201-33850
2	Oil Filler	027-06317	1	1	1
3	Strainer Plate	291-23751	1	1	1
4	Bush	601-39740	1	1	1
5	Joint	201-33011	1	1	1
6	Oil Seal	201-30690	1	1	1
7	Oil Filler Cap	027-03824	1	1	1
-	Oil Filler Cap Joint	303-00253	1	1	1
8	Washer	027-00082	7	7	7
9	Bolt - M8 x 70mm	272-00179	7	7	7
10	Dowel	351-13660	2	2	2
11	Camshaft Oil Seal	601-39550	1	1	1
13	Nylon Cap	351-36580	1	1	1

Illustration T391

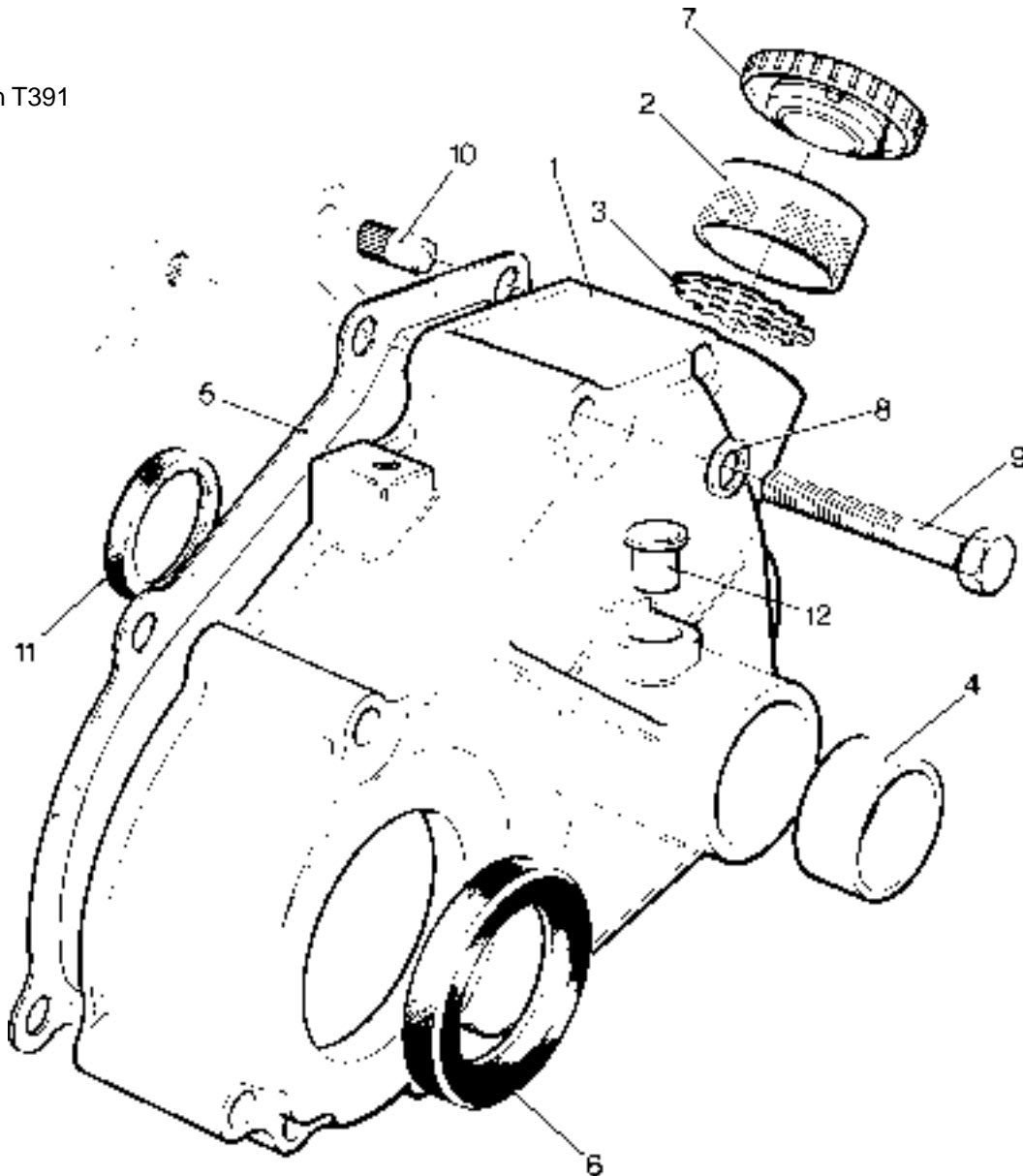

Flywheel and Fanshroud - TS/TR1

Not Builds 16, 17, 101, 102

Illustration T158

No.	Description	Part Number	TS/TR			Remarks
			1	2	3	
1	Fanshroud	202-33664	1	-	-	Replaces 201-41051 & 201-41050
2	Self-lock Setscrew - M10 x 25mm	272-00621	6	-	-	
3	Blanking Plug	201-46130	1	-	-	No longer used
4	Bolt - M10 x 55mm	272-00050	2	-	-	
5	Disc Spring Washer	202-24060	2	-	-	
6	Blanking Plug	351-36580	1	-	-	
7	Flywheel Assembly - TS	570-42021	1	-	-	Builds 01, 03, 06, 10, 14, 60, 64, 101
-	Flywheel Assembly - TS	570-42022	1	-	-	Build 04
-	Flywheel Assembly - TS	570-42023	1	-	-	Build 12
-	Flywheel Assembly - TS/TR	570-42025	1	-	-	Builds 08, 62, 78. With Integral fan
-	Flywheel Assembly - TS	570-42027	1	-	-	Build 40
-	Flywheel Assembly - TR	570-42031	1	-	-	Build 01, 03, 06, 10, 14
8	Flywheel		1	-	-	
9	Gear Ring	202-30520	1	-	-	
10	Fan - TS1	201-39911	1	-	-	Not fitted where fan is integral
-	Fan - TR1	202-33540	1	-	-	Not fitted where fan is integral
11	Capscrew - M8 x 30mm	272-00176	8	-	-	Not fitted where fan is integral
12	Spring Washer	272-00089	8	-	-	Not fitted where fan is integral
13	Flywheel Nut	202-33790	1	-	-	
14	Lock Washer	202-33800	1	-	-	
15	Key	201-80550	1	-	-	
16	Starter Motor Blanking Plate	201-38230	1	-	-	
17	Spring Washer	272-00072	3	-	-	
18	Setscrew - M10 x 16mm	272-00124	3	-	-	
19	Setscrew - M6 x 16mm	272-00034	2	-	-	
20	Spring Washer	272-00070	2	-	-	

Illustration T158

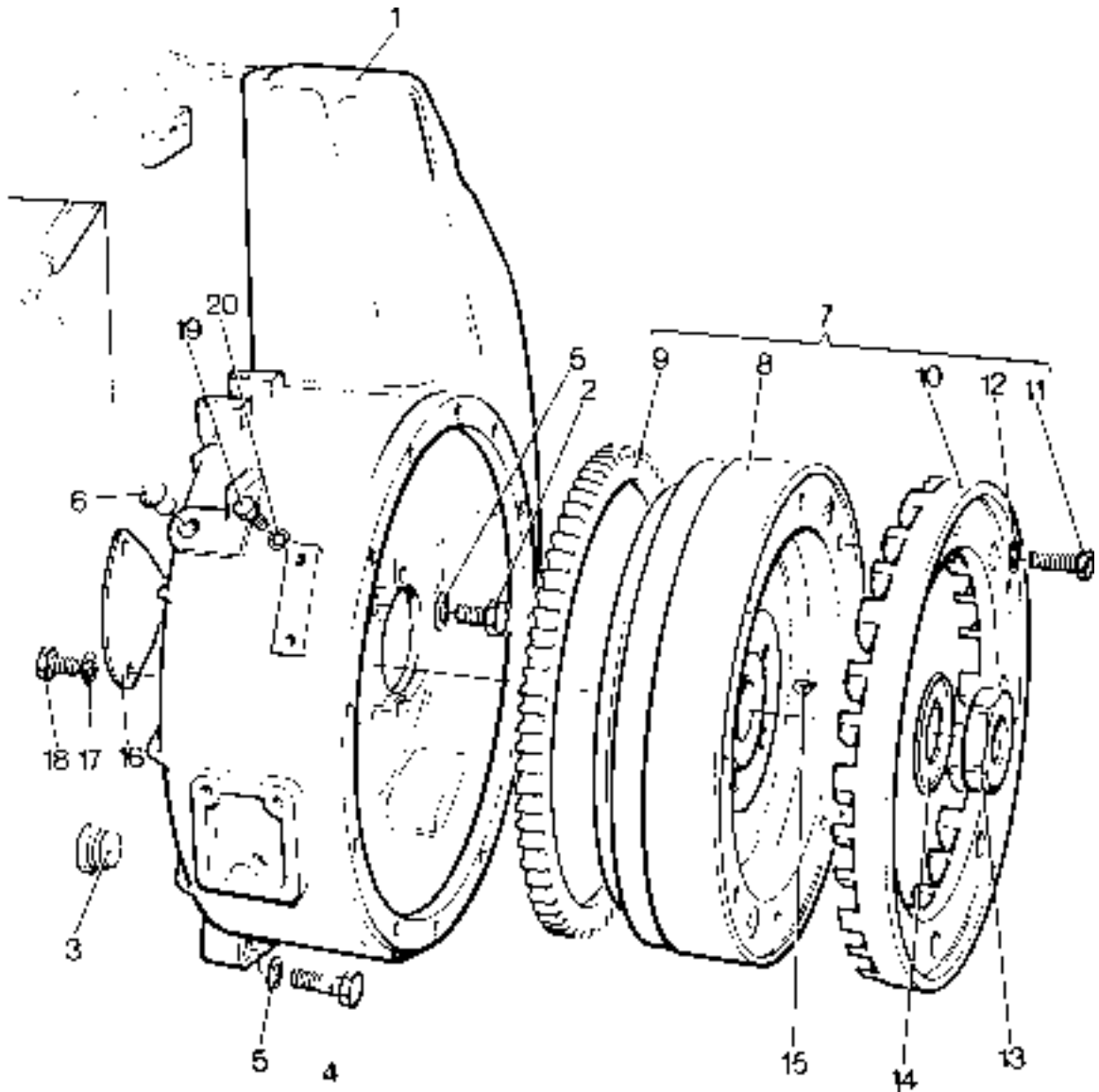

Flywheel and Fanshroud

TS1 Builds 16, 17, 101, 102

TR1 Builds 16, 17

Illustration T172

No. Description

Part Number

TS/TR

1 2 3 Remarks

No.	Description	Part Number	1	2	3	Remarks
-	Flywheel Assembly - TS1	570-33160	1	-	-	
-	Flywheel Assembly - TR1	570-33340	1	-	-	
1	Flywheel		1	-	-	
2	Fan	201-41510	1	-	-	
3	Cheese Head Screw - M6 x 35mm	272-00265	6	-	-	
4	Spring Washer	272-00086	6	-	-	
5	Key	201-80550	1	-	-	
6	Flywheel Nut	202-33790	1	-	-	
7	Lock Washer	202-33800	1	-	-	
8	Sheet Metal Fan Shroud	201-41390	1	-	-	
9	Air Seal	201-41460	1	-	-	
10	Spring Disc Washer	202-24060	6	-	-	
11	Setscrew - M10 x 20mm	272-00241	6	-	-	
12	Retainer	201-41540	1	-	-	
-	Lockwasher	272-00086	2	-	-	Builds 101, 102
13	Setscrew - M6 x 20mm	272-00117	2	-	-	
14	Setscrew - M6 x 12mm	272-00032	1	-	-	
15	Spring Washer	272-00070	1	-	-	

Illustration T172

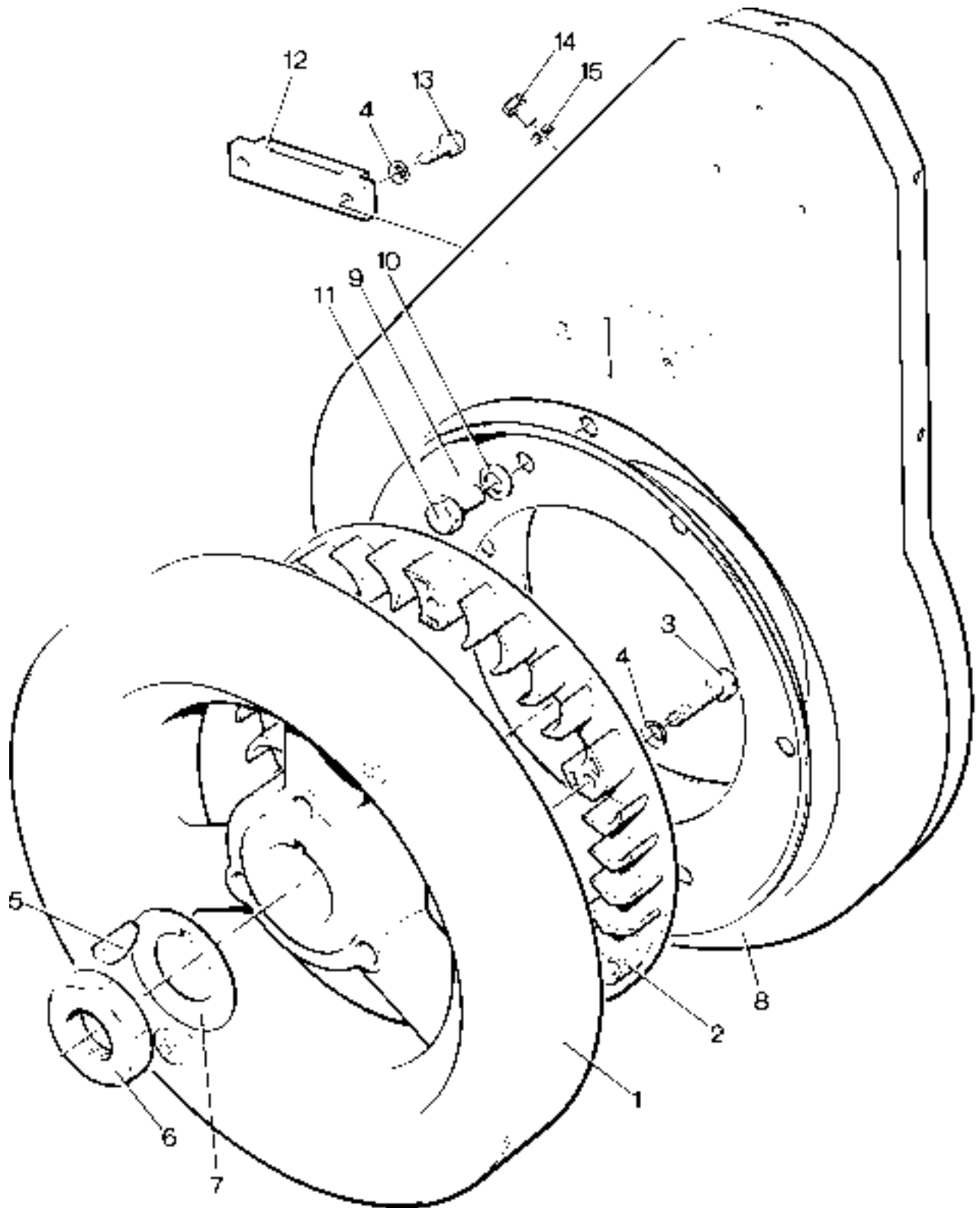

Flywheel and Fanshroud - TS/TR2,3

Illustration T7 No.	Description	Part Number	TS/TR			Remarks
			1	2	3	
1	Fanshroud - TS2,3 and TR2	202-33664	-	1	1	
-	Fanshroud - TR3	570-41562	-	-	1	Replaces 202-33665
2	Baffle - TR3	203-43011	-	-	1	See Note
3	Setscrew - M6 x 16mm - TR3	272-00034	-	-	3	See Note
4	Nut - TR3	272-00002	-	-	3	See Note
5	Spring Washer - TR3	272-00070	-	-	3	See Note
6	Setscrew	272-00621	-	6	6	
7	Bolt - M10 x 55mm	272-00050	-	2	2	
8	Disc Spring Washer	202-24060	-	2	2	
9	Blanking Plug	351-36580	-	1	1	
10	Flywheel Assembly - TS2	570-42041	-	1	-	Builds 01, 03, 05, 06, 10, 60
-	Flywheel Assembly - TS2	570-42042	-	1	-	Builds 04
-	Flywheel Assembly - TS2	570-42043	-	1	-	Build 12
-	Flywheel Assembly - TS/TR2	570-42045	-	1	-	Builds 08, 14, 62, 78. With Integral Fan
-	Flywheel Assembly - TS2	570-42047	-	1	-	Builds 40, 41, 42
-	Flywheel Assembly - TR2	570-42051	-	1	-	Builds 01, 06, 50
-	Flywheel Assembly - TR2	570-42052	-	1	-	Build 04
-	Flywheel Assembly - TR2	570-42053	-	1	-	Builds 12
-	Flywheel Assembly - TR2	570-42017	-	1	-	Build 101
-	Flywheel Assembly - TS/TR3	570-42061	-	-	1	Builds 01, 03, 05, 06, 08, 10, 50, 60, 62, 78
-	Flywheel Assembly - TS3	570-42062	-	-	1	Build 04
-	Flywheel Assembly - TS/TR3	570-42063	-	-	1	Build 12
-	Flywheel Assembly - TS3	570-42065	-	-	1	Builds 40, 41, 42
11	Flywheel		-	1	-	
12	Gear Ring	202-30520	-	1	1	
13	Fan - TS/TR2	202-33540	-	1	-	Not fitted where fan is integral
-	Fan - TS/TR3	203-33540	-	-	1	
14	Capscrew - M8 x 30mm - TS/TR2,3	272-00176	-	8	8	Not fitted where fan is integral
15	Spring Washer	272-00089	-	8	8	Not fitted where fan is integral
16	Flywheel Nut	202-33790	-	1	1	
17	Lock Washer	202-33800	-	1	1	
18	Key	201-80550	-	1	1	
19	Starter Motor Blanking Plate	201-38230	-	1	1	
20	Spring Washer	272-00072	-	3	3	
21	Setscrew - M10 x 16mm	272-00124	-	3	3	
22	Blanking Plug	201-46130	-	1	1	No longer fitted

Note:

Only fitted on TR3 and from 3600014TR3.

Illustration T7

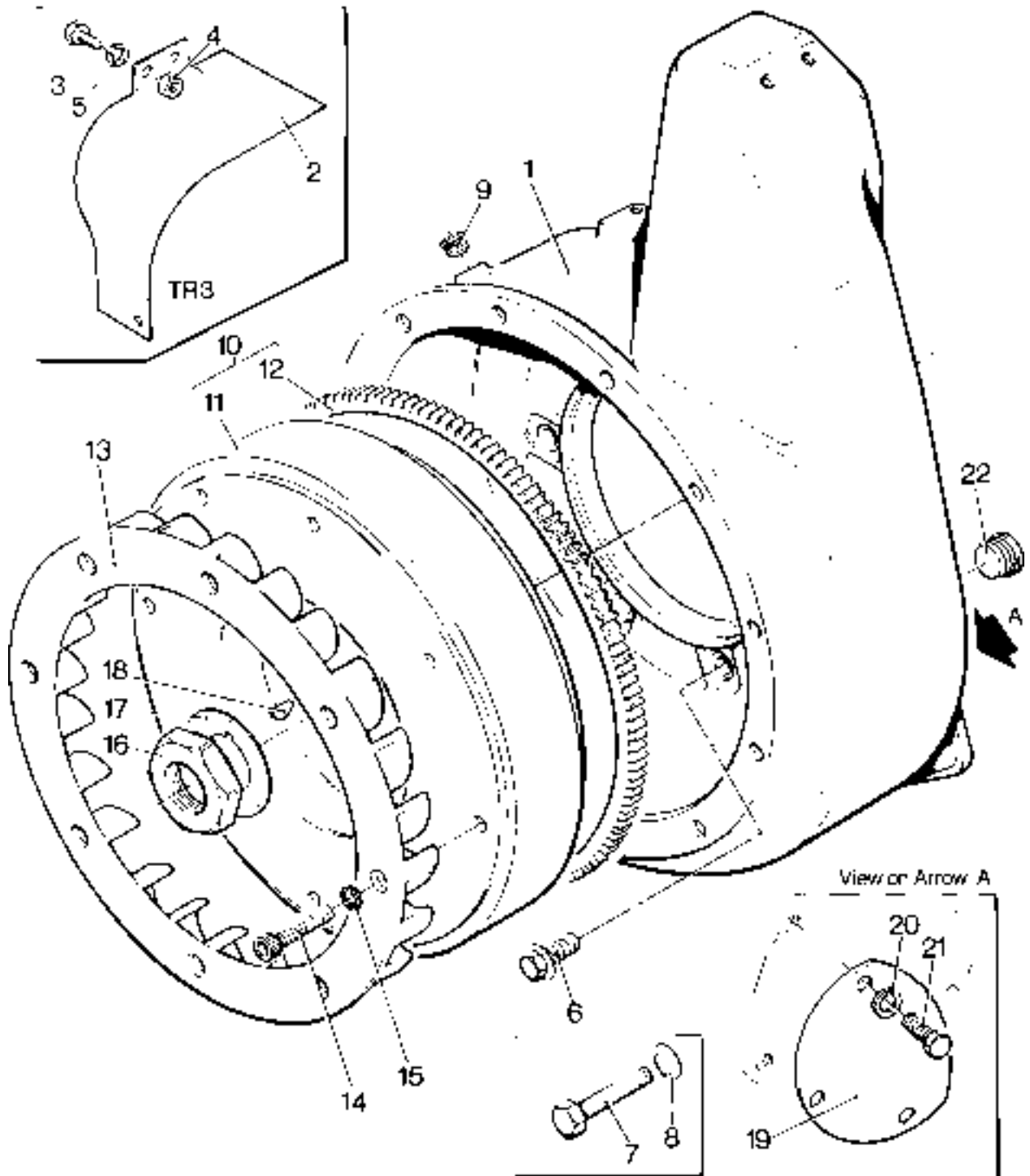

Flywheel Charge Windings - Synchro

From the following engine numbers refer to "Flywheel Charge Windings - Nicsa".
The Synchro and Nicsa systems are not interchangeable.

4100433TS1 4101651TS2 4101568TS3
4100240TR1 4100281TR2 4100301TR3

Illustration T155F No. Description	Part Number	TS/TR			Remarks
		1	2	3	
- Flywheel Assembly - TS1	570-31081	1	-	-	No longer available
- Flywheel Assembly - TS1	570-31101	1	-	-	Build 04. No longer available
- Flywheel Assembly - TS/TR2,3	202-41950	-	1	1	No longer available
- Flywheel Assembly - TS/TR2,3	202-41951	-	1	1	Build 04. No longer available.
1 Flywheel Assembly - TR1	570-33800	1	-	-	No longer available
- Flywheel Assembly - TR1	570-31150	1	-	-	Build 07. No longer available
- Flywheel Assembly - TR1	570-33820	1	-	-	Build 04. No longer available
2 Flywheel		1	1	1	
3 Gear Ring	202-30520	1	1	1	
4 Rotor		1	1	1	
- Fan - TS1	201-39911	1	-	-	
5 Fan - TR1	202-33540	1	-	-	Replaces 201-42710
- Fan - TS2	202-33540	-	1	-	Replaces 202-33541
- Fan - TS3,TR2,3.....	203-33540	-	1	1	Replaces 203-33541
6 Lock Washer	272-00089	8	8	8	
7 Capscrew - M8 x 30mm	272-00176	8	8	8	Required if replacing 202-33541 or 203-33541 fans
8 Key	201-80550	1	1	1	
9 Nut.....	202-33790	1	1	1	
10 Locking Washer	202-33800	1	1	1	
11 Stator Assembly	201-45570	1	1	1	Replaces 602-36640. No longer available. See Note:
12 Capscrew	270-00765	6	6	6	
13 Spring Washer	027-00717	6	6	6	
14 Cable Strap	602-37600	1	1	1	
15 Taptite Screw - M4 x 8mm	272-00282	2	2	2	
- Main Bearing Housing Assembly	570-30603	1	1	1	Replaces 570-30601
16 Main Bearing Housing	201-42890	1	1	1	
- Main Bearing Assembly	570-30011	1	1	1	
17 Setscrew - M8 x 25mm	272-00040	6	6	6	
18 Spring Washer	272-00071	6	6	6	
19 Regulator Cover	202-37710	1	1	1	For 602-36900
20 Stud	202-37970	2	2	2	
- Regulator and Rectifier Kit	570-41701	1	1	1	Replaces 602-36900 & 570-41700
21 Regulator	360567	1	1	1	
22 Mounting Plate Assembly	201-45590	1	1	1	
23 Screw - M6 x 16mm	272-00034	2	2	2	
24 Copper Washer - 1/4" diameter	291-26090	2	2	2	
25 Setscrew	712008	2	2	2	
26 Spring Washer.....	786003	2	2	2	
27 Terminal Adaptor	382-07807	1	1	1	Replaced by 064-15649/007
- Ring Termination	064-15649/007	1	1	1	Replaces 382-07807
28 Push-on Connector	064-33068/002	4	4	4	
29 Insulation Cover	064-33991/001	4	4	4	
30 Inline Connector	366-06915	2	2	2	

Note:

Synchro Stator 201-45570 is no longer available but can be replaced by Nicsa Stator and Regulator Kit 570-42120.

Illustration T155F

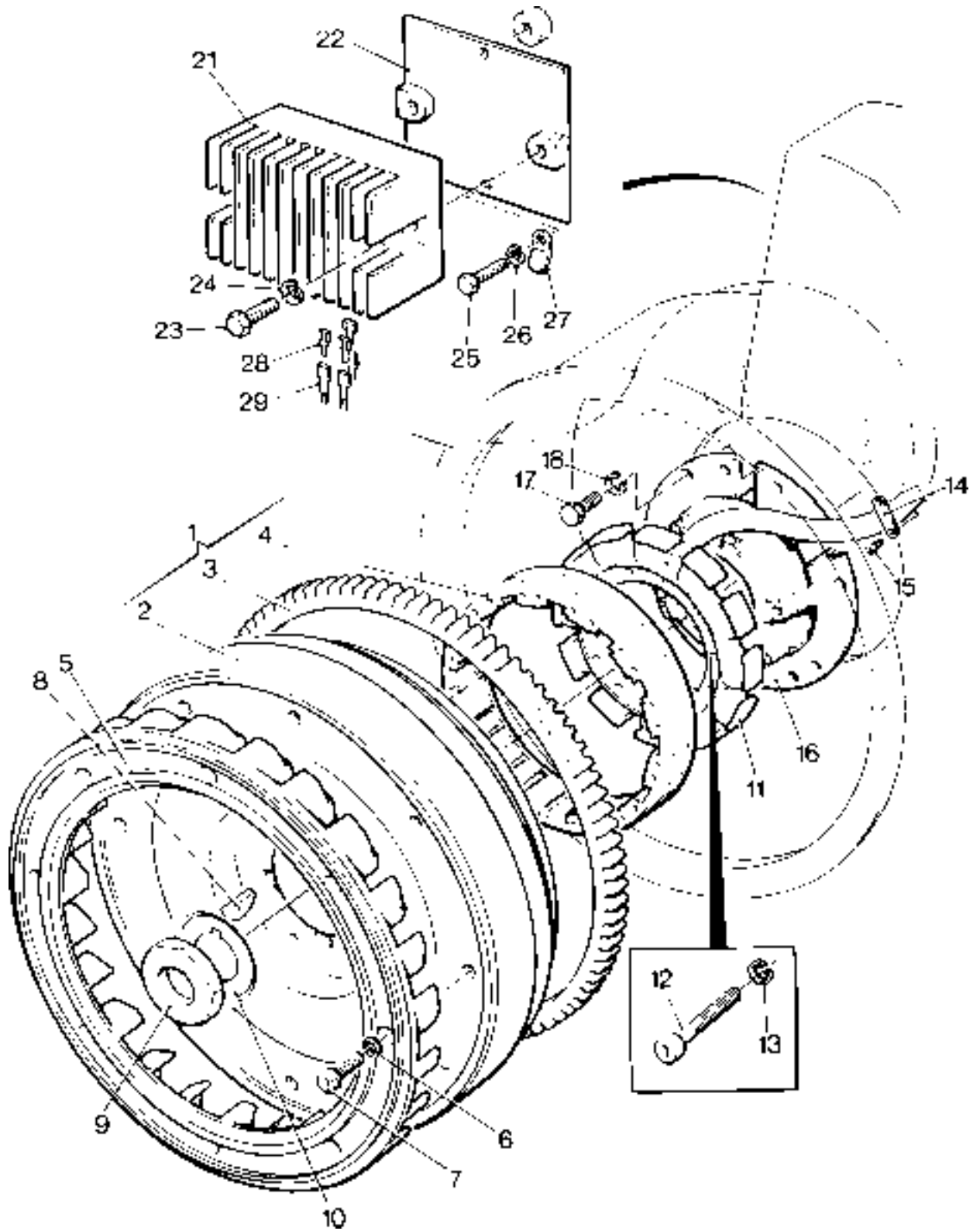

Flywheel Charge Windings - Nicsa

Before the following engine numbers refer to "Flywheel Charge Windings - Synchro". The Nicsa and Synchro systems are not interchangeable.

4100433TS1	4101651TS2	4101568TS3
4100240TR1	4100281TR2	4100301TR3

Illustration 155G No. Description	Part Number	TS/TR			Remarks
		1	2	3	
- Flywheel Assembly - TS1	570-42022	1	-	-	Build 02, 07, 11, 15, 61, 65, 66
- Flywheel Assembly - TS1	570-42024	1	-	-	Build 04, 13
- Flywheel Assembly - TR1	570-42032	1	-	-	Build 02, 07, 11, 15
- Flywheel Assembly - TR1	570-42034	1	-	-	Build 04
- Flywheel Assembly - TS/TR1	570-42026	1	-	-	Builds 09,63. With Integral Fan
1 Flywheel Assembly - TS2	570-42042	-	1	-	Builds 02, 07, 11, 61, 66
- Flywheel Assembly - TS2	570-42044	-	1	-	Build 04, 13
- Flywheel Assembly - TR2	570-42052	-	1	-	Build 02, 07
- Flywheel Assembly - TR2	570-42054	-	1	-	Build 04, 13
- Flywheel Assembly - TS/TR2	570-42046	-	1	-	Builds 09,15, 63. With Integral Fan
- Flywheel Assembly - TS/TR3	570-42062	-	-	1	Builds 02, 07, 09, 11, 61, 63, 66
- Flywheel Assembly - TS/TR3	570-42064	-	1	-	Build 04, 13
2 Flywheel		-	1	-	
3 Gear Ring	202-30520	1	1	1	
4 Rotor	366-08143	1	1	1	
5 Caphead Screw - M6 x 20mm	272-00388	6	6	6	
- Fan - TS1	201-39911	1	-	-	
- Fan - TR1	202-33540	1	-	-	Replaces 201-42710
6 Fan - TS/TR2	202-33540	-	1	-	Replaces 202-33541
- Fan - TS/TR3	203-33540	-	-	1	Replaces 203-33541
7 Lock Washer	272-00089	8	8	8	
8 Capscrew - M8 x 30mm	272-00176	8	8	8	Required if replacing 202-33541 or 203-33541
9 Key	201-80550	1	1	1	
10 Nut	202-33790	1	1	1	
11 Lock Washer	202-33800	1	1	1	
12 Stator Assembly	366-08142	1	1	1	
13 Capscrew	270-01081	6	6	6	Replaces 270-00765
14 Spring Washer	027-00717	6	6	6	
15 Cable Strap	602-37601	1	1	1	
16 Taptite Screw - M4 x 8mm	272-00282	2	2	2	
17 Main Bearing Housing Assembly	570-30603	1	1	1	Replaces 570-30601
- Main Bearing Housing	201-42890	1	1	1	
- Main Bearing Assembly	570-30011	1	1	1	
18 Setscrew - M8 x 25mm	272-00040	6	6	6	
19 Spring Washer	272-00071	6	6	6	
20 Regulator	366-08144	1	1	1	
21 Self-lock Screw	272-00752	2	2	2	
22 Connector	366-08145	1	1	1	
23 Push-on Connector	366-07265	1	1	1	
24 Push-on Connector	366-08151	1	1	1	
25 Push-on Connector	366-08152	1	1	1	
- Connection Diagram	742-00647				

Notes:

1. 201-46177 with integral fan replaces 201-46172
2. 202-46175 with integral fan replaces 202-46171

Cylinder Head

Illustration T13 No.	Description	Part Number	TS/TR			Remarks
			1	2	3	
-	Cylinder Head Assembly TS1	570-32940	1	-	-	With valves & springs. See Note
-	Cylinder Head Assembly TS2,3	570-30730	-	2	3	With valves & springs. See Note
-	Cylinder Head Assembly TR	570-33630	1	2	3	With valves & springs. See Note
1	Cylinder Head - TS	570-36500	1	2	3	
2	Inlet Valve Insert	201-80051	1	2	3	
3	Exhaust Valve Insert	201-80041	1	2	3	
-	Cylinder Head - TR	570-36520	1	2	3	
-	Inlet Valve Insert	201-33050	1	2	3	
-	Exhaust Valve Insert	201-33060	1	2	3	
4	Top Plate		1	2	3	
5	Inlet Valve Guide	201-30181	1	2	3	
6	Exhaust Valve Guide	201-30171	1	2	3	
7	Inlet Valve Guide Oil Seal	201-81200	1	2	3	
8	Breather Tube	201-30191	1	2	3	
9	Copper Washer	616-01608	2	4	6	
10	Setscrew - M8 x 10mm	272-00239	1	2	3	
11	Spring Carrier - bottom	201-55660	1	2	3	No longer fitted
12	Cylinder Head Gasket - TS	201-80210	1	2	3	
13	Shim - 0,076mm - TS	201-80220				Use as required
-	Shim - 0,254mm - TS	201-80221				Use as required
12	Cylinder Head Gasket - TR	201-33110	1	2	3	
13	Shim - 0,076mm - TR	201-33100				Use as required
-	Shim - 0,254mm - TR	201-33101				Use as required
14	Lubricating Oil Pipe	202-31790	1	2	3	
15	Cylinder Head Nut	270-00005	2	4	6	
16	Inlet Valve - TS	201-30040	1	2	3	
-	Inlet Valve - TR	201-33070	1	2	3	
17	Exhaust Valve - TS	201-30051	1	2	3	
-	Exhaust Valve - TR	201-33080	1	2	3	
18	Inlet Valve Stem Shield	201-37630	1	2	3	
19	Exhaust Valve Stem Shield	201-39520	-	2	3	
20	Valve Spring	201-30080	2	4	6	
21	Cotter	201-50921	2	4	6	Replaces 201-50920. Pair supplied
22	Spring Carrier - top	201-80230	2	4	6	
23	Valve Rocker Lever	201-30650	2	4	6	
24	Bush	351-50170	2	4	6	
25	Adjusting Screw	201-30110	2	4	6	
26	Nut	272-00003	2	4	6	
27	Stub Shaft	201-30640	2	4	6	
28	'O' Ring	201-31460	2	4	6	
29	Decompressor Lever	201-30461	1	2	3	
30	Oil Seal	201-81200	1	2	3	
31	Spring	201-30480	1	2	3	
32	Circlip	353-81780	1	2	3	
33	Screw	201-30470	1	2	3	
34	Nut	272-00002	1	2	3	
35	Tappet	351-10210	2	4	6	
36	Push Rod	201-30100	2	4	6	
37	Sealing Tube	201-30150	2	4	6	
38	Bottom Rubber Cup	201-30261	2	4	6	
39	Top Rubber Cup	201-42360	2	4	6	
40	Cylinder Head Stud	201-30990	4	8	12	
	Accessory Kit Code EJ - TS/TR2	570-31740	1	1	1	Comprises no's 41, 42
	Accessory Kit Code EJ - TS/TR3	570-32100	1	1	1	Comprises no's 41, 42
41	Coupled Decompressor Link - TS/TR2,3	202-17330	-	1	2	
42	Cheese Head Screw - M4 x 20mm	272-00344	-	2	3	
43	Self-lock Nut	272-00371	-	2	3	
44	Breather Plate Sealing Ring	601-35440	1	2	3	

Note:

All Cylinder Head Assemblies comprise of no's 1-10, 14 & 16-22

Illustration T13

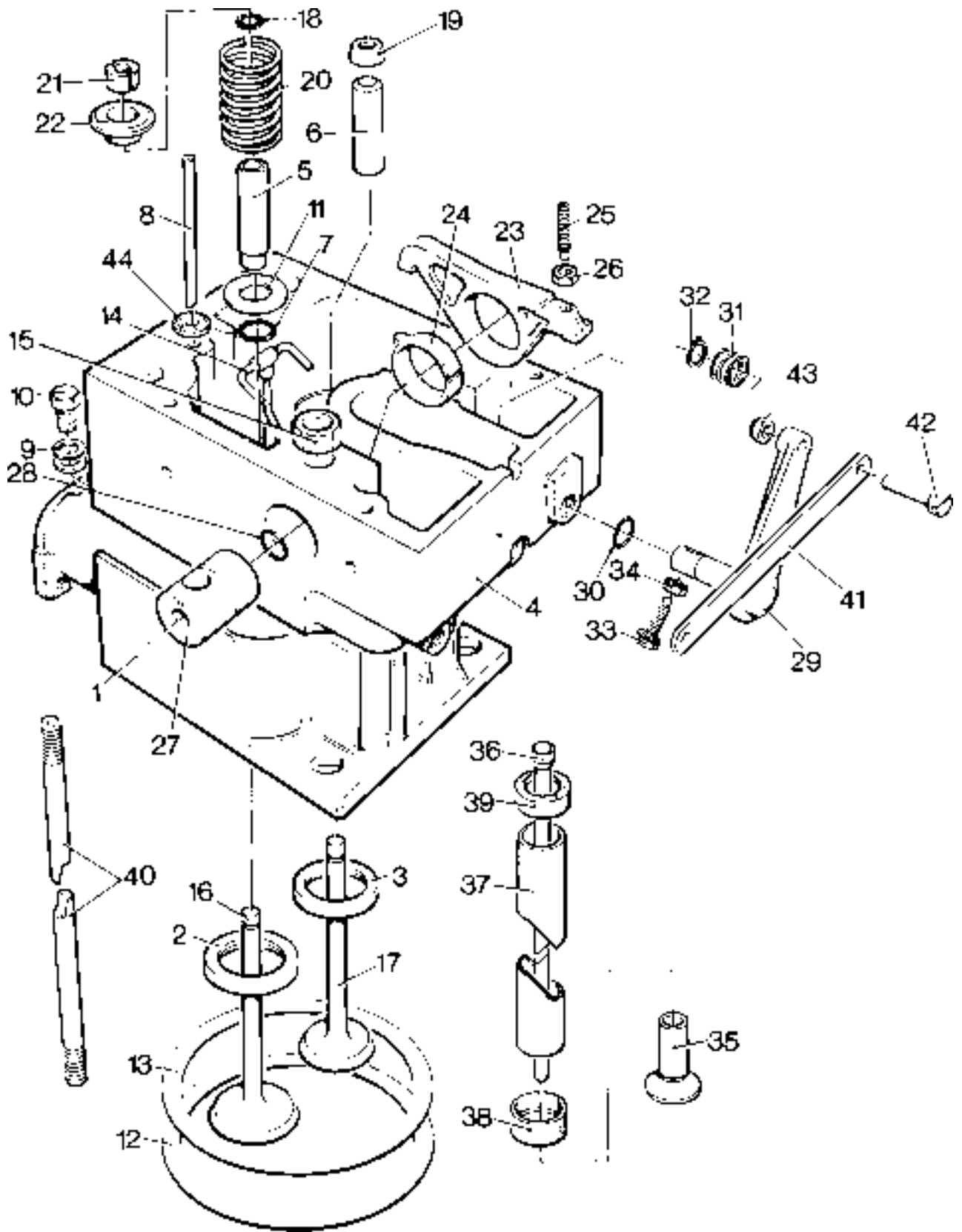

Cylinder Head Cover

Illustration T18 No.	Description	Part Number	TS/TR			Remarks
			1	2	3	
1	Cylinder Head Cover	570-30742	1	2	3	
-	Cylinder Head Cover	201-30798	-	2	3	TS2,3 Builds 08,09,11. Only one is fitted on TR2 Build 101
-	Gear End Cylinder Head Cover - TS/TR1	570-30753	1	-	-	With mounting facility for gauge or 13.5 litre fuel tank. Not used on Build 102
-	Gear End Cylinder Head Cover - TS/TR1	570-30752	1	-	-	With mounting facility for gauge or 13,5 litre fuel tank. Used on Build 102
-	Gear End Cylinder Head Cover - TS/TR2,3	570-30752	-	1	1	With mounting facility for gauge or 13.5 litre fuel tank.
2	Joint	201-30805	1	2	3	
3	Bolt - M6 x 25mm	272-00256	4	8	12	
4	Washer	272-00364	4	8	12	
5	Breather Plate Sealing Ring	601-35440	1	2	3	
6	Lifting Eye	202-36540	1	1	1	
7	Pillar Nut	202-36550	2	2	2	
-	Nut	270-00005	1	5	9	All TS Builds 40,41,42
8	Setscrew - 7/16" UNF x 1"	270-00335	2	2	2	
9	Spring Washer	027-00984	2	2	2	

Note:

Accessory Code QD available (570-35890) consisting of -
 Gear End Cylinder Head Cover (570-30752 replaces 570-30753)
 Joint (201-30805)

Illustration T18

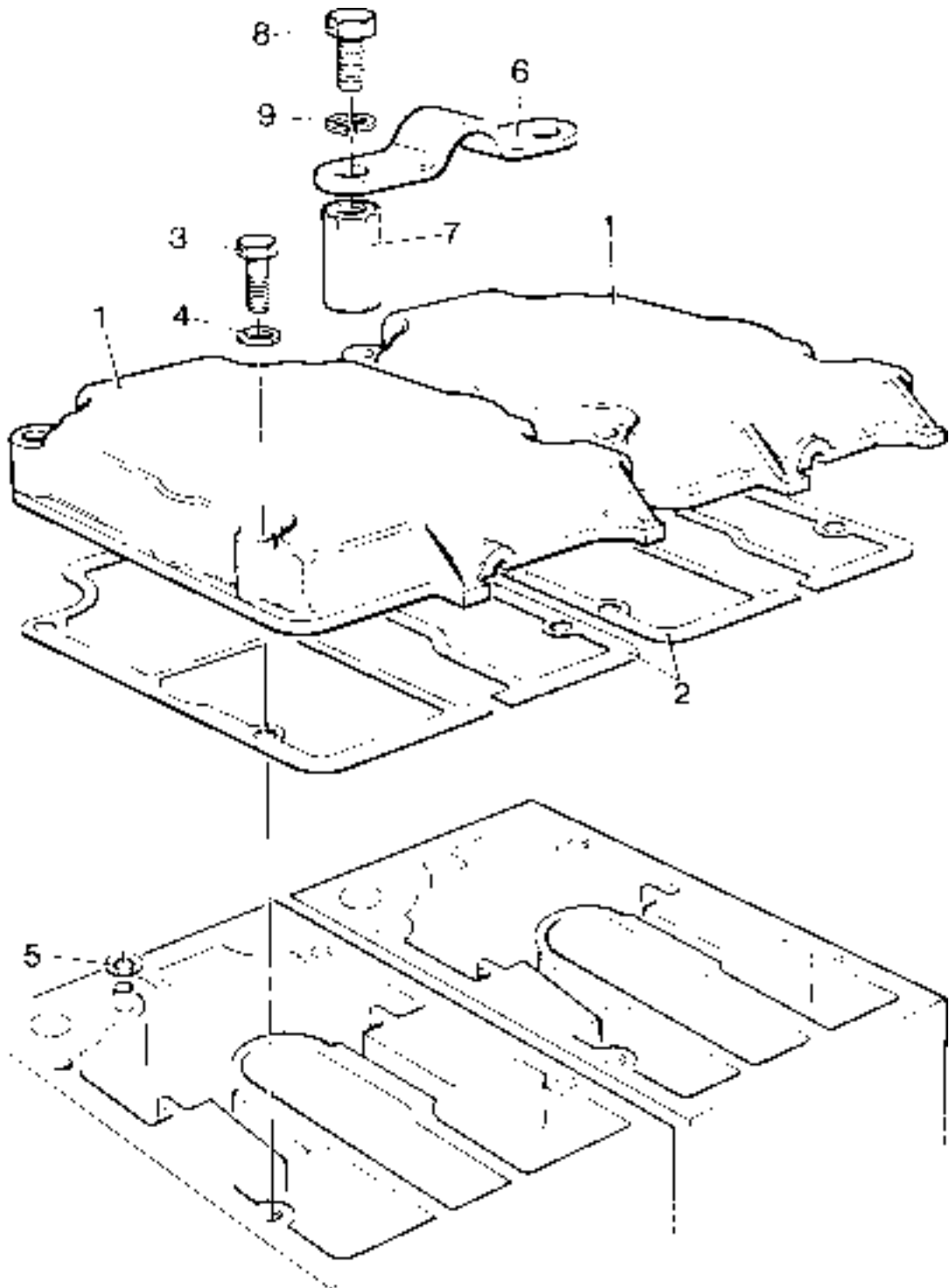

Air Duct, Cowling, Shields - TS/TR1

Illustration T156 No. Description	Part Number	TS/TR			Remarks
		1	2	3	
Accessory Kit Code DA	570-32820	1	-	-	Comprises of 3 items below
- Air Outlet Duct Adaptor	201-38100	1	-	-	
- Setscrew - M6 x 12mm	272-00032	3	-	-	Use with 201-38100 (above)
- Spring Washer	272-00070	3	-	-	
1 Air Cowling Assembly	201-37833	1	-	-	Replaces 201-37830 & 201-37832. Not Builds 16-18
- Air Cowling Assembly	201-37832	1	-	-	Builds 16-18, 101. Replaces 201-37830
2 Setscrew - M6 x 12mm	272-00032	3	-	-	
3 Spring Washer	272-00070	3	-	-	
4 Setscrew - M8 x 20mm	272-00039	2	-	-	Not Builds 16-18
5 Spring Washer	272-00071	2	-	-	Not Builds 16-18
6 Blind Grommet	201-50950	1	-	-	
7 Gear End Side Shield	201-37880	1	-	-	
- Gear End Side Shield - TS1	201-39851	1	-	-	Build 40
- Gear End Side Shield - TS1	201-42750	1	-	-	Builds 60,61,62,63
8 Setscrew - M6 x 16mm	272-00034	1	-	-	
- Setscrew - M6 x 12mm	272-00032	2	-	-	
9 Spring Washer	272-00070	3	-	-	
10 Washer	027-00618	3	-	-	
11 Setscrew - M8 x 16mm	272-00038	2	-	-	
12 Spring Washer	272-00071	2	-	-	
13 Washer	027-00082	1	-	-	
14 Flywheel End Side Shield - TS1	202-34270	1	-	-	Not Builds 16, 17, 40
- Flywheel End Side Shield - TS1	201-42760	1	-	-	Builds 60,61,62,63 and replaces 201-39850
- Flywheel End Side Shield - TR1	202-42400	1	-	-	Not Builds 16, 17
15 Setscrew - M6 x 12mm	272-00032	3	-	-	
16 Spring Washer	270-00070	3	-	-	
17 Washer	027-00618	3	-	-	
18 Setscrew - M8 x 20mm	272-00039	1	-	-	
19 Spring Washer	272-00071	1	-	-	
- Fir Tree Button	201-48130	1	-	-	
Accessory Kit Code EU - TS/TR1	570-32830	1	-	-	Cold Start Oil Cups Kit comprising no's 20, 21, 22
20 Cold Start Reservoir and Plunger Assembly	201-26480	1	-	-	See Note
21 Adaptor	201-30890	1	-	-	See Note. Screws into inlet manifold port
22 Grommet	201-12951	1	-	-	Fitted in place of 201-50950 See Note
23 Plain Washer	272-00751	1	-	-	
24 Clamping Plate	202-39120	1	-	-	Not Builds 16-18

Note:

No longer fitted as standard. Available as spares, either separately or all 3 items under kit EU.

Illustration T156

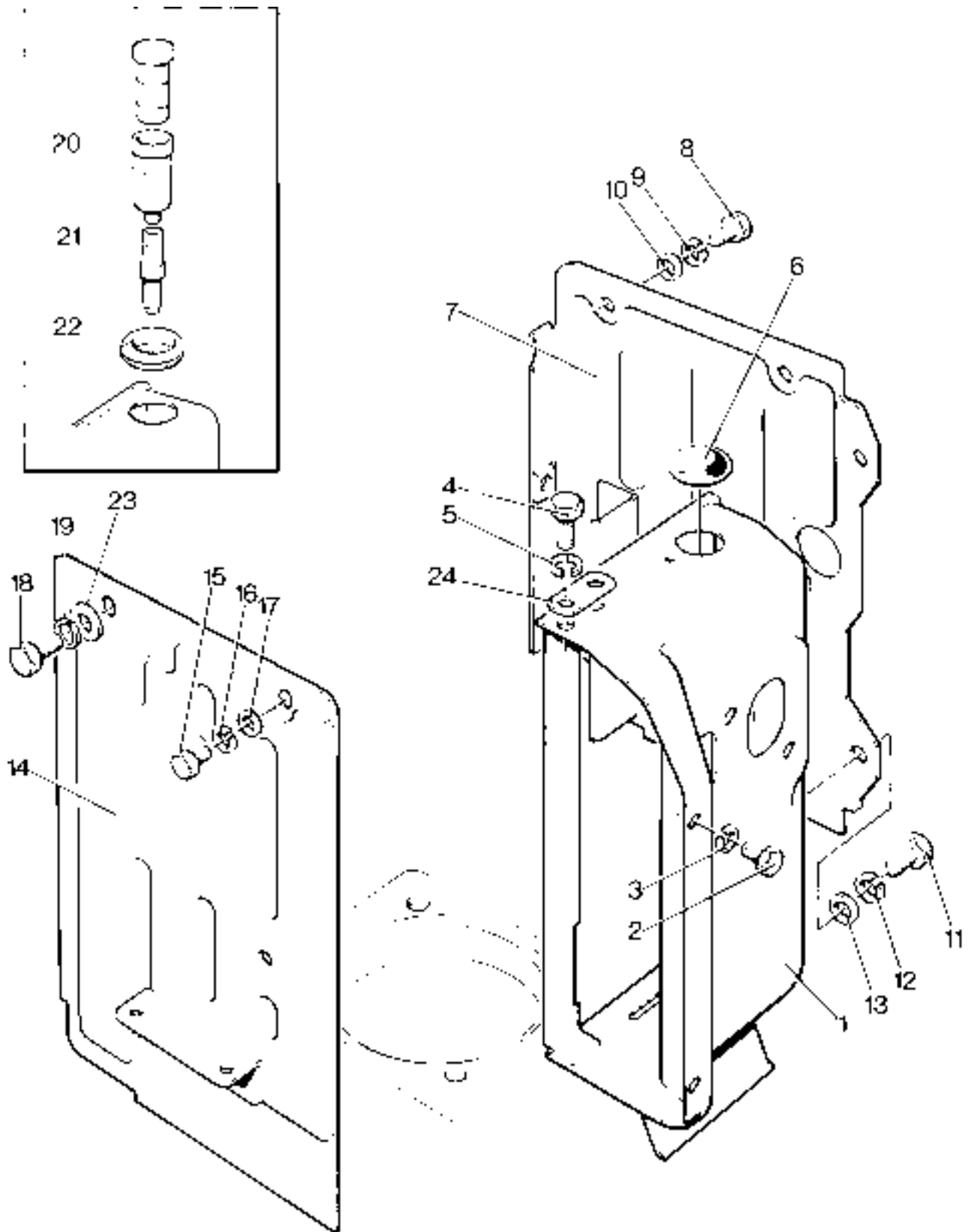

Air Duct, Cowling, Shields

TS1 Builds 16, 17, 101, 102

TR1 Builds 16, 17

Illustration T166

No.	Description	Part Number	TS/TR			Remarks
			1	2	3	
1	Side Shield Assembly - TS	201-41520	1	-	-	
-	Side Shield Assembly - TR	201-44690	1	-	-	
2	Setscrew - M6 x 12mm	272-00032	1	-	-	
3	Spring Washer	272-00070	1	-	-	
4	Washer	027-00618	1	-	-	
5	Setscrew - M8 x 12mm	272-00166	1	-	-	Not used on Builds 101, 102
-	Setscrew - M8 x 20mm	272-00039	1	-	-	Builds 101, 102
6	Spring Washer	272-00071	1	-	-	
7	Air Cowling Assembly	201-37832	1	-	-	Replaces 201-37830
8	Setscrew - M6 x 12mm	272-00032	3	-	-	
9	Spring Washer	272-00070	3	-	-	
10	Grommet	201-50950	1	-	-	
-	Plain Washer	027-00082	1	-	-	Builds 101, 102

Illustration T166

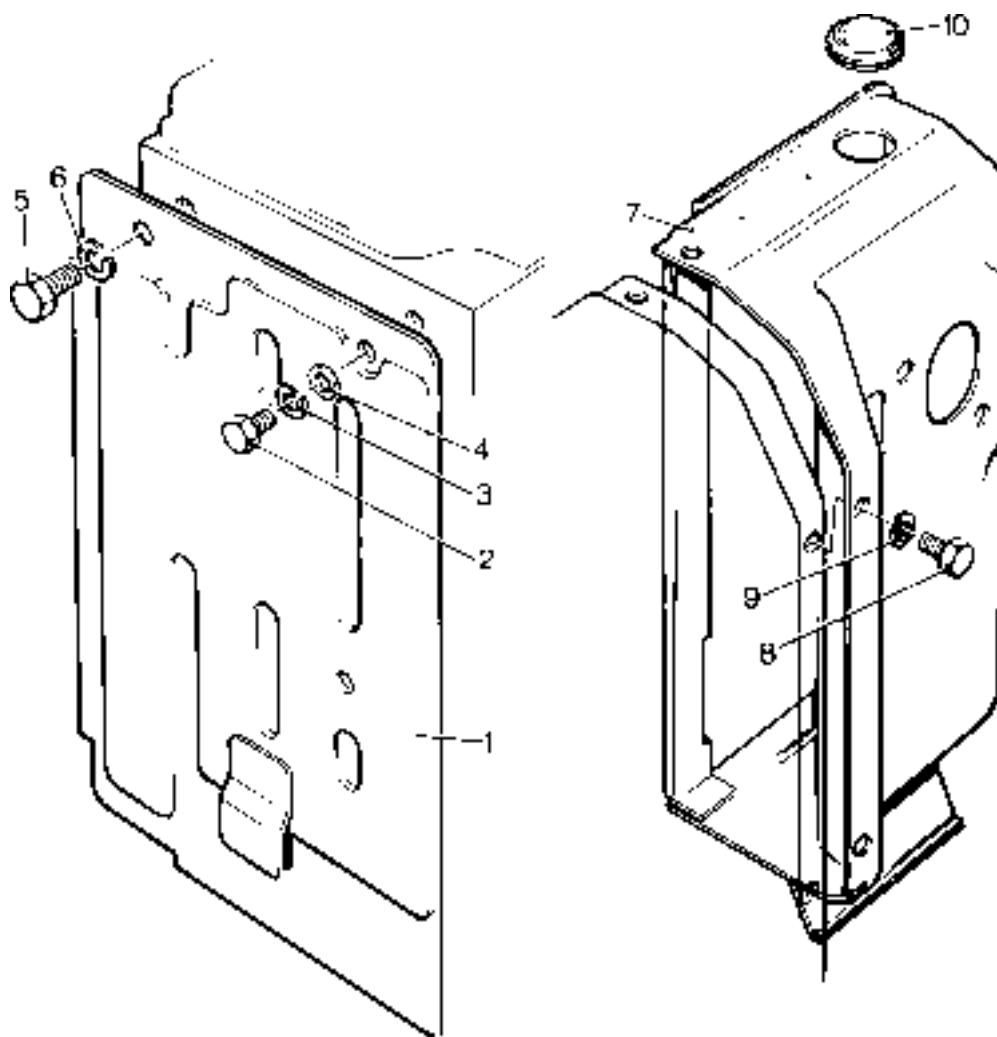

Fuel Filter - TS Build 102

Side Shield and Fuel Filter - TS1 - Build 40

Illustration T389
No. Description

Part Number TS/TR
1 2 3 Remarks

No.	Description	Part Number	TS	TR	Remarks
1	Flywheel End Side Shield	201-42760	1	-	- Replaces 201-39850
2	Grommet	201-41830	1	-	-
3	Grommet	201-41840	1	-	-
4	Fuel Filter Mounting Bracket	201-44770	1	-	-
-	Fuel Filter Mounting Bracket	202-34261	1	-	- Build 102
5	Washer	202-80680	2	-	-
6	Setscrew - M6 x 12mm	272-00032	2	-	-
7	Washer	027-00618	2	-	-
8	Spring Washer	272-00070	3	-	-
9	Bolt - M6 x 30mm	272-00035	1	-	-
10	Bolt - M8 x 30mm	272-00041	1	-	-
11	Spring Washer	272-00071	1	-	-
12	Fuel Filter	201-44580	1	-	- Replaced by Agglomerator
-	Element Kit	351-29760	1	-	-
-	Agglomerator	750-14120	1	-	- Replaces Fuel Filter 201-44580
-	Element Kit	751-18100	1	-	-
13	Setscrew - M8 x 25mm	272-00039	2	-	-
14	Washer	272-00359	2	-	-
-	Plain Washer	027-00082	2	-	- Build 102
15	Self-locknut	272-00373	2	-	-
16	Ball	202-32120	2	-	- Replaces Washer 201-41640
17	Union	202-42370	2	-	- Replaces Plug 354-28530
-	Union	202-42371	1	-	- Build 102
-	Olive	351-21640	1	-	- Build 102

Illustration T389

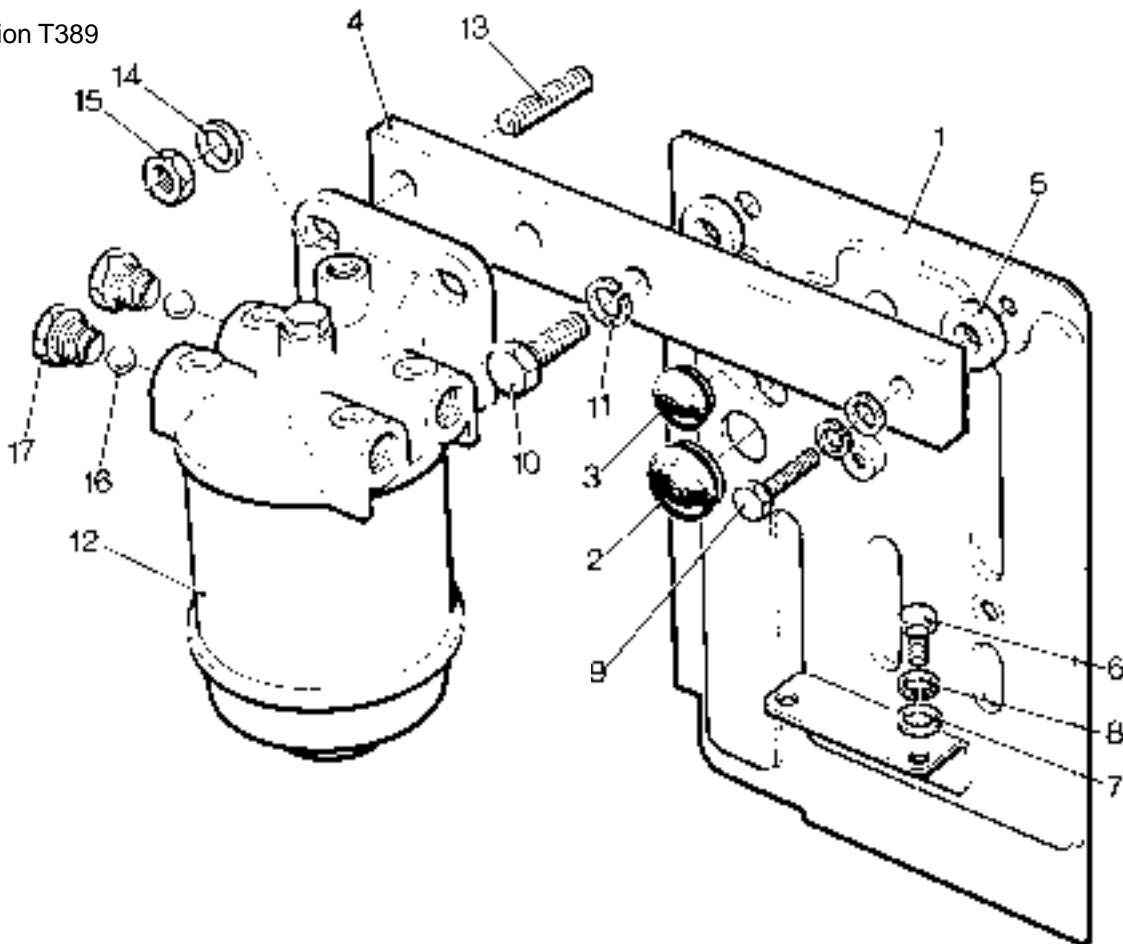

Air Duct, Cowling and Shields - TS/TR2,3

Illustration T9 and T371 No. Description	Part Number	TS/TR			Remarks
		1	2	3	
Accessory Kit Code DA - TS/TR2	570-31670	-	1	-	See Illustration T371
- Air Outlet Duct Adaptor	202-31593	-	1	-	
- Setscrew - M6 x 12mm	272-00032	-	4	-	
- Spring Washer	272-00070	-	4	-	
Accessory Kit Code DA - TS/TR3	570-32090	-	-	1	
- Air Outlet Duct Adaptor	203-31591	-	-	1	
- Setscrew - M6 x 12mm	272-00032	-	-	4	
- Spring Washer	272-00070	-	-	4	
1 Air Cowling Assembly - TS2	202-30742	-	1	-	Not Builds 41, 60, 61, 62, 63,104
- Air Cowling Assembly - TS3	203-30742	-	-	1	Not Builds 41, 60, 61, 62, 63,104
- Air Cowling Assembly - TR2	202-42421	-	1	-	
- Air Cowling - TR2	202-30742	-	1	-	
- Damping Pad - TR2	202-42430	-	1	-	
- Air Cowling Assembly - TR3	203-42421	-	-	1	
- Air Cowling - TR3	203-30742	-	-	1	
- Damping Pad - TR3	203-42430	-	-	1	
2 Setscrew - M8 x 20mm	272-00039	-	2	2	
3 Spring Washer	272-00071	-	2	2	
4 Setscrew - M6 x 12mm	272-00032	-	2	2	
5 Spring Washer	272-00070	-	2	2	
6 Blind Grommet	201-50950	-	2	3	
7 Clamping Plate	202-39120	-	1	1	
8 Air Baffle	201-33830	-	1	2	
9 Tie	201-33821	-	1	2	Replaces 201-33820
10 Spring Clip	353-71370	-	1	2	
11 Split Pin	027-00957	-	1	2	
12 Gear End Side Shield -TS2,3	201-37880	-	1	1	
- Gear End Side Shield -TR2,3	201-42750	-	1	1	
13 Setscrew - M6 x 12mm	272-00032	-	2	2	
- Setscrew - M6 x 16mm	272-00034	-	1	1	
14 Spring Washer	272-00070	-	3	3	
15 Washer	027-00618	-	3	3	
16 Setscrew - M8 x 16mm	272-00038	-	2	2	
17 Spring Washer	272-00071	-	2	2	
18 Washer	027-00082	-	1	1	
19 Flywheel End Side Shield - TS2,3	202-34270	-	1	1	
- Flywheel End Side Shield - TR2,3	202-42400	-	1	1	
20 Setscrew - M6 x 12mm	272-00032	-	4	4	
21 Spring Washer	270-00070	-	4	4	
22 Washer	027-00618	-	4	4	
23 Setscrew - M8 x 25mm	272-00040	-	1	1	
24 Spring Washer	272-00071	-	1	1	
25 Washer	027-00082	-	1	1	
Accessory Kit Code EU - TS/TR2	570-31770	-	1	-	Cold Start Oil Cups Kit comprising no's 26, 27, 28
Accessory Kit Code EU - TS/TR3	570-32110	-	-	1	Cold Start Oil Cups Kit comprising no's 26, 27, 28
26 Cold Start Reservoir and Plunger Assembly	201-26480	-	1	1	See Note
27 Adaptor	201-30890	-	2	3	See Note. Screws into inlet manifold port
28 Grommet	201-12951	-	2	3	Fitted in place of 201-50950 See Note

Note:

No longer fitted as standard. Available as spares, either separately or all 3 items under kit EU.

Illustration T9

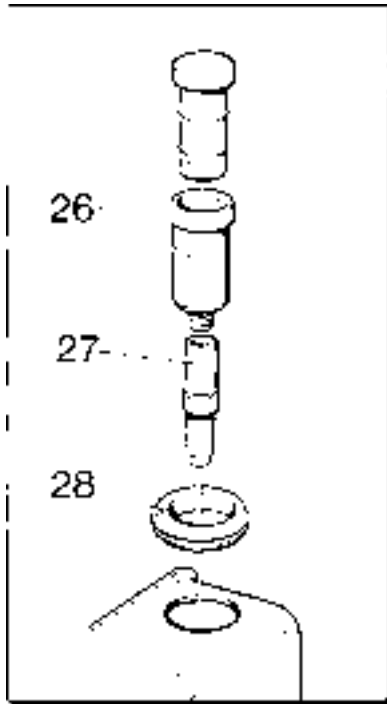
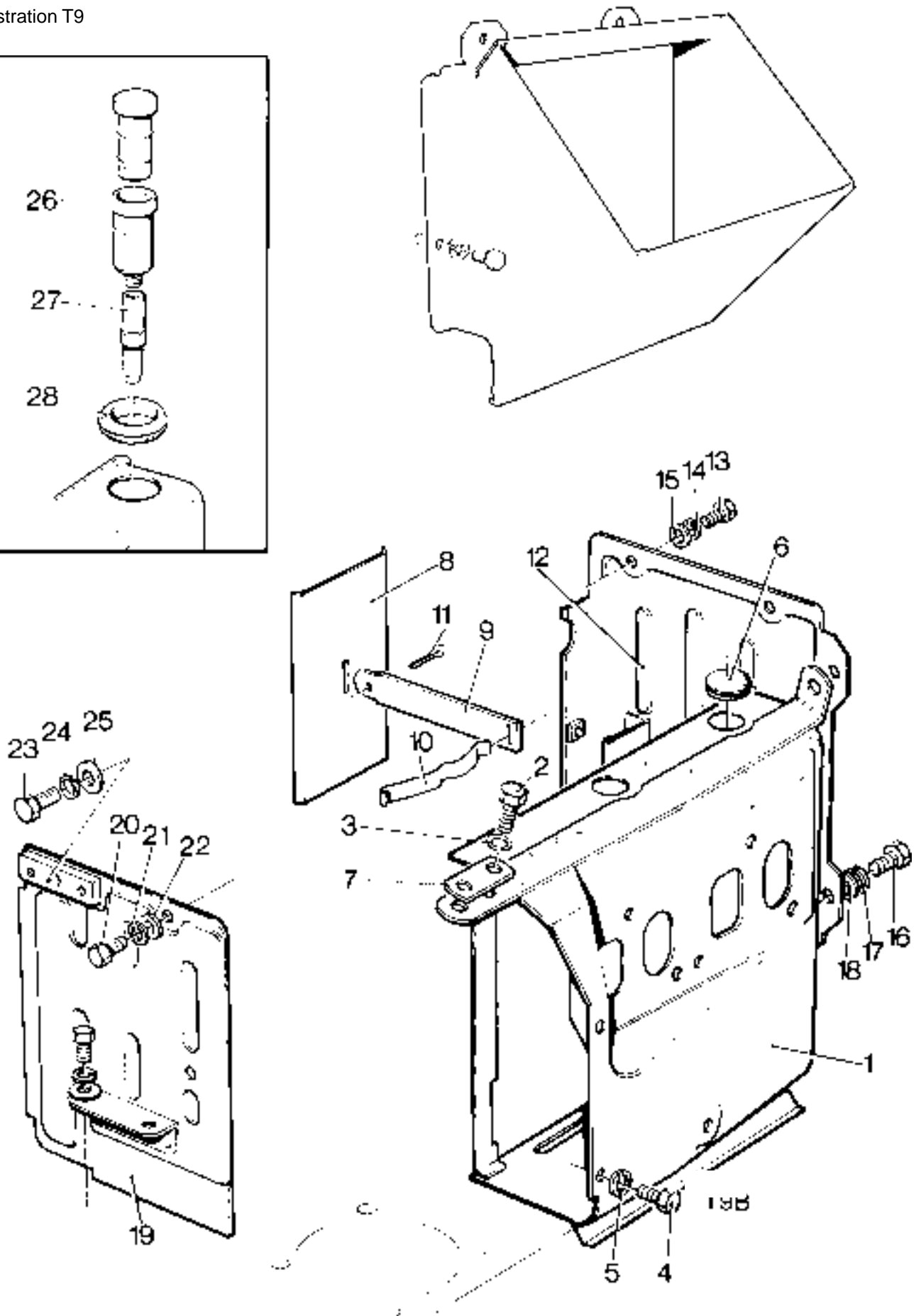

Illustration T371



Air Duct, Cowling and Shields

TS/TR2,3 Builds 41, 60, 61, 62, 63, 104

Illustration T134

No.	Description	Part Number	TS/TR			Remarks
			1	2	3	
1	Air Cowling - TS/TR2	202-42421	-	1	-	
-	Air Cowling	202-30742	-	1	-	
-	Damping Pad	202-42430	-	1	-	
-	Air Cowling - TS/TR3	203-42421	-	-	1	
-	Air Cowling	203-30742	-	-	1	
-	Damping Pad	203-42430	-	-	1	
2	Setscrew - M8 x 20mm	272-00039	-	2	2	
3	Spring Washer	272-00071	-	2	2	
4	Setscrew - M6 x 12mm	272-00032	-	2	2	
5	Spring Washer	272-00070	-	2	2	
6	Grommet	201-50950	-	2	3	
7	Clamping Plate	202-39120	-	1	1	
8	Air Baffle	201-33830	-	1	2	
9	Tie	201-33820	-	1	2	
10	Spring Clip	353-71370	-	1	2	
11	Split Pin	027-00957	-	1	2	
12	Gear End Side Shield	201-42750	-	1	1	Replaces 202-42380
13	Setscrew - M6 x 12mm	272-00032	-	2	2	Three were fitted
-	Setscrew - M6 x 16mm	272-00034	-	1	1	Replaces 1 of 272-00032
14	Spring Washer	272-00070	-	3	3	
15	Washer	027-00618	-	3	3	
16	Setscrew - M8 x 16mm	272-00038	-	2	2	
17	Spring Washer	272-00071	-	2	2	
18	Washer	027-00082	-	2	2	
19	Flywheel End Side Shield	202-42400	-	1	1	
20	Setscrew - M4 x 40mm	272-00082	-	1	1	
21	Spring Washer	272-00070	-	4	4	
22	Washer	027-00618	-	4	4	
23	Setscrew - M8 x 25mm	272-00040	-	1	1	
24	Spring Washer	272-00071	-	1	1	
-	Setscrew - M6 x 14mm	272-00033	-	2	2	Build 104

Flywheel End Side Shield - TS/TR1

Illustration T416

No.	Description	Part Number	TS/TR			Remarks
			1	2	3	
	Accessory Kit Code DF	570-33770	1	-	-	
1	Side Shield Assembly	201-39851	1	-	-	
2	Grommet	201-41840	1	-	-	
3	Grommet	201-41830	1	-	-	

Note:

For use with codes JC or PF.

Illustration T134

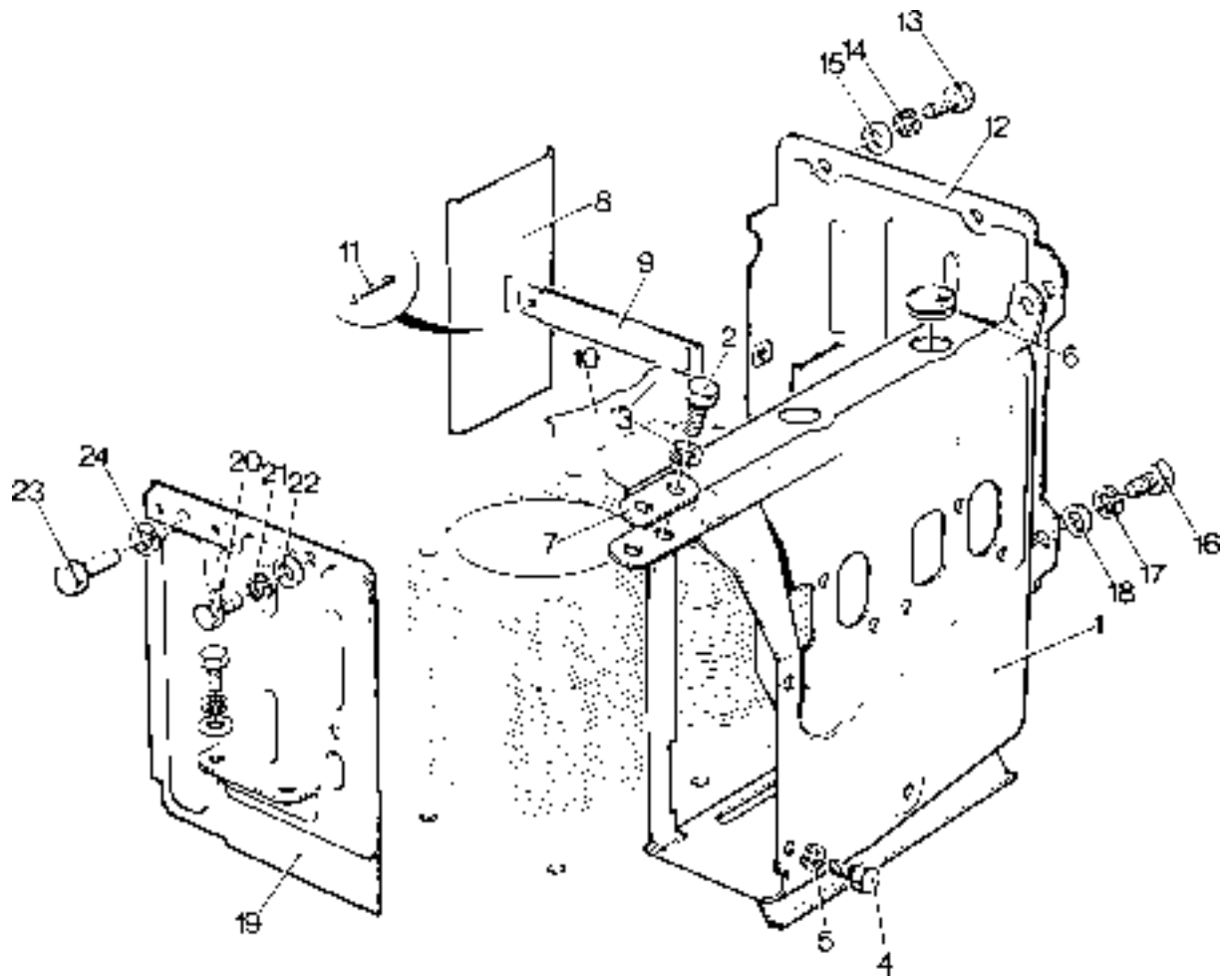
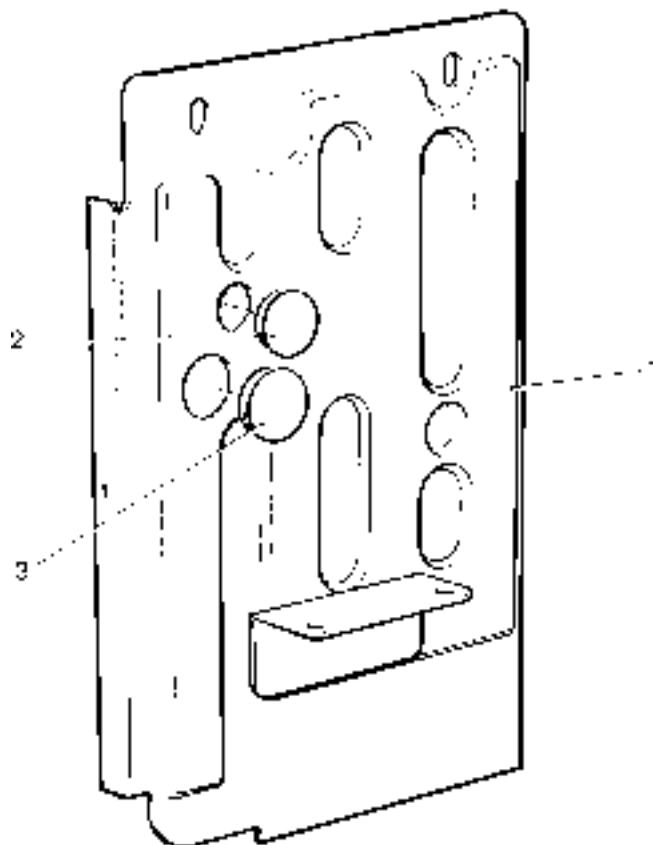

Illustration T416



Fuel Lift Pump - AC Delco & Pienne

Illustration T388

The AC Delco type was last fitted on:

3802252TS1 3800753TR1

3800286TS2 3800002TR2

3800261TS3 3800093TR3

No.	Description	Part Number	TS/TR			Remarks
			1	2	3	
-	Fuel Lift Pump - AC Delco	602-40480	1	1	1	Replaced by Pienne then Corona
1	Fuel Lift Pump - TS/TR1 - Pienne	201-45343	1	-	-	Replaced by Corona pump
-	Fuel Lift Pump - TS/TR2,3 - Pienne	201-45345	-	1	1	Replaced by Corona pump
2	Push Rod	201-30550	1	1	1	
3	Union - 1/2" UNF	202-42371	1	1	1	
4	Olive	351-21640	1	1	1	
5	Union	202-42370	2	2	2	
6	Olive	601-38360	2	2	2	
7	Setscrew - M8 x 16mm	272-00038	4	4	4	
8	Spring Washer	272-00071	4	4	4	
-	Pipe Clip	201-42640	1	-	-	
-	Clip Felt	201-17170	1	-	-	
-	Fuel Pipe - TS/TR1	201-39961	1	-	-	
9	Fuel Pipe - TS1	201-44741	1	-	-	Build 40
-	Fuel Pipe - TS/TR2	202-44871	-	1	-	
-	Fuel Pipe - TS/TR3	203-44871	-	-	1	
10	Joint	602-36721	1	1	1	
11	Union	354-26260	1	1	1	
12	Washer	354-26310	2	2	2	
-	Pienne Pump Repair Kit	027-07897				

Note:

To convert from an AC Delco pump or Pienne pump to a current Corona Pump use:

TS/TR1 - Accessory Kit Code FE (570-32810)

TS/TR2 - Accessory Kit Code FE (570-34690)

TS/TR3 - Accessory Kit Code FE (570-34700)

Illustration T388

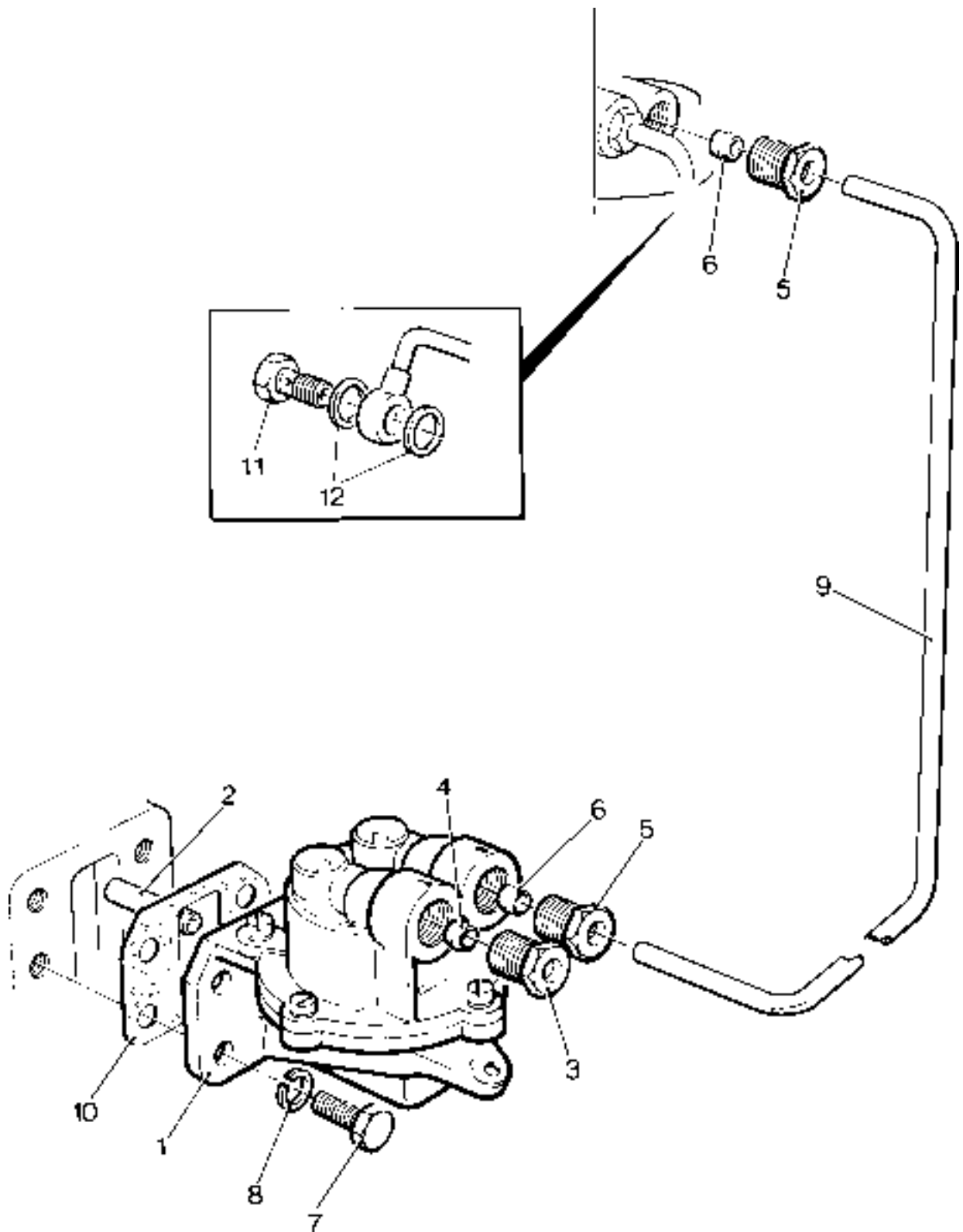

Fuel Lift Pump - Corona

Illustration T415

No.	Description	Part Number	TS/TR			Remarks
			1	2	3	
	Accessory Kit Code FE - TS/TR1	570-32810	1	-	-	
	Accessory Kit Code FE - TS/TR2	570-34690	-	1	-	
	Accessory Kit Code FE - TS/TR3	570-34700	-	-	1	
1	Fuel Pipe - TS/TR1	201-44871	1	-	-	
2	Fuel Pipe - TS/TR2	202-44871	-	1	-	
-	Fuel Pipe - TS/TR3	203-44871	-	-	1	
3	Union	202-42370	2	2	2	
4	Olive	601-38360	2	2	2	
5	Push Rod	201-30550	1	1	1	
6	Joint	602-36721	1	1	1	
7	Fuel Lift Pump	201-46296	1	-	-	
-	Repair Kit	027-10043	1	-	-	Not part of kit FE
8	Fuel Lift Pump	201-46298	-	1	1	
-	Repair Kit	027-10041	-	1	1	Not part of kit FE
9	Screw - M8 x 16mm	272-00038	4	4	4	
10	Union	202-42371	1	1	1	
11	Olive	351-21640	1	1	1	
12	Felt	201-17170	1	-	-	
13	Clip	351-19920	1	-	-	

Illustration T415

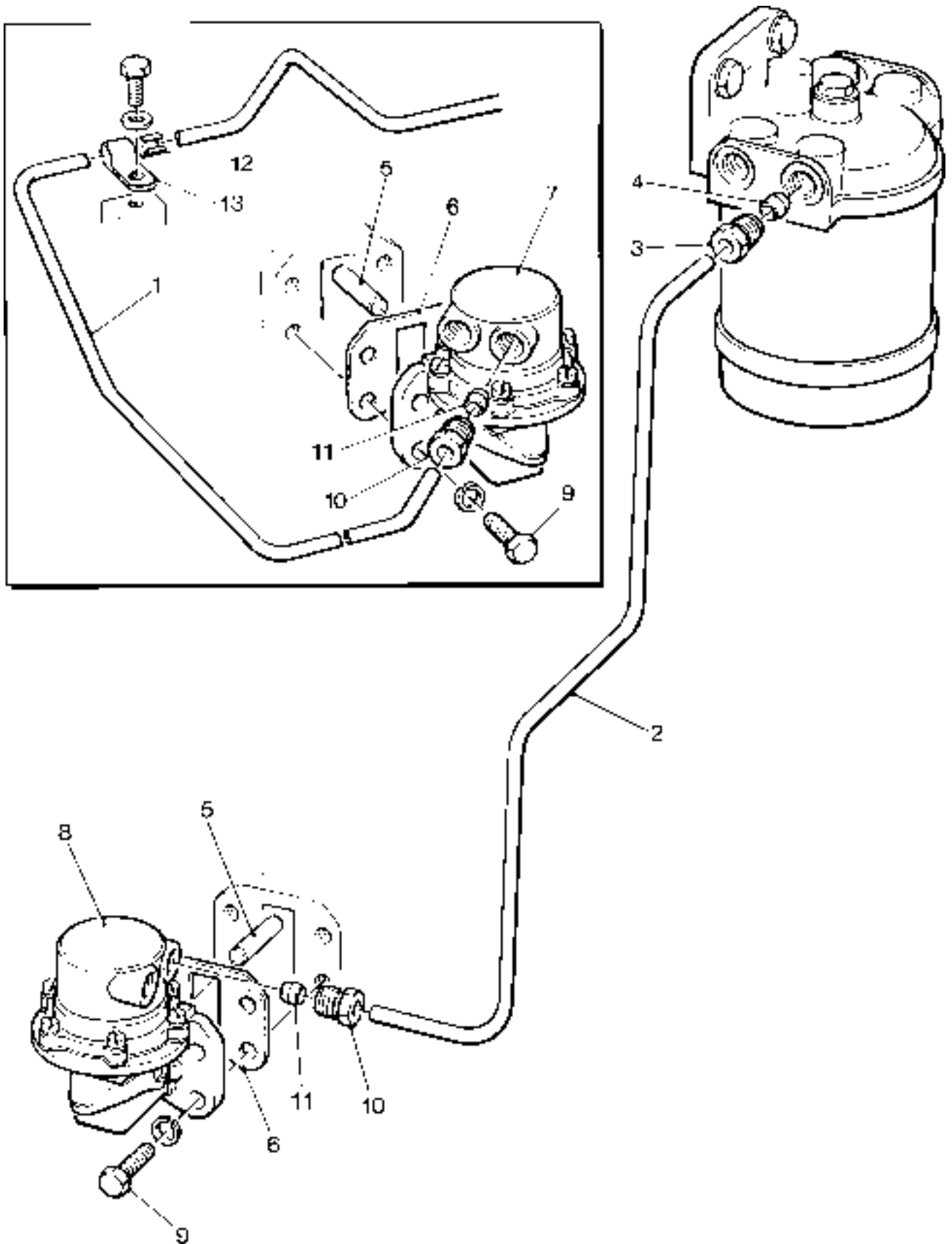

Fuel Filter and Pump - TS/TR1 (Early Type)

Illustration T159 No.	Description	Part Number	TS/TR			Remarks
			1	2	3	
1	Filter Bracket	601-31732	1	-	-	
2	Bolt - M6 x 25mm	272-00256	2	-	-	
3	Spacer	366-04966	2	-	-	
4	Spring Washer	272-00070	2	-	-	
5	Bleed Screw	601-21620	2	-	-	
6	Washer	601-32470	2	-	-	
7	Fuel Filter Adaptor	601-34690	1	-	-	
-	Bowl and Element Assembly	570-31260	1	-	-	
8	Bowl		1	-	-	
9	Locating Washer		1	-	-	
10	Spring		1	-	-	
11	Bolt Assembly		1	-	-	
12	Element Kit	203-32470	1	-	-	
13	Sealing Ring		1	-	-	
14	Sealing Ring		1	-	-	
15	Sealing Ring		2	-	-	
16	Fuel Pump Tappet Assembly	570-30770	1	-	-	
17	Tappet		1	-	-	
18	Roller	601-21390	1	-	-	
19	Bush	601-21400	1	-	-	
20	Pin	601-21410	1	-	-	
21	Fuel Pump Tappet Guide	201-30120	1	-	-	
22	Locating Pin	201-39680	1	-	-	
23	Cap	201-30140	1	-	-	
24	Fuel Pump	201-31303	1	-	-	See Note ¹
-	Element	660-14260	1	-	-	See Note ¹
-	Delivery Valve	660-14270	1	-	-	See Note ¹
-	Vent Screw	3/485A	1	-	-	See Note ¹
25	Shim - 0,127mm	201-45961				Use as required. See Note ²
-	Shim - 0,762mm	201-45962				Use as required. See Note ²
-	Shim - 1,016mm	201-45963				Use as required. See Note ²
-	Shim - 1,270mm	201-45964				Use as required. See Note ²
26	Bolt - M6 x 45mm	272-00165	2	-	-	
27	Spring Washer	272-00070	2	-	-	
28	'O' Ring	601-20691	1	-	-	
29	Fuel Pipe Assembly	570-35700	1	-	-	Replaces 201-38940
30	Copper Washer	616-01608	2	-	-	
31	Swivel Union Plug	202-34000	1	-	-	
32	Connection	602-38250	1	-	-	
33	Washer	354-26310	1	-	-	
34	Inlet Connection Adaptor	201-39660	1	-	-	
35	Washer	354-26310	1	-	-	
36	Flexible Pipe Assembly	366-07044	1	-	-	

Notes:

- The current pump being fitted is Lucas Dizel. Before replacing any other pump refer to Lister Petter Diesel Centre or distributor.
- The new type pump timing shims were first fitted on the following engines and both types must not be mixed on the same pump.
 4000213TS1 4000113TR1
 4300318TS1 4300299TR1
 The sikle type fuel timing shim were:
 0,127mm 602-21870 0,508mm 602-21872
 0,254mm 602-21871 0,762mm 602-21873

Illustration T159

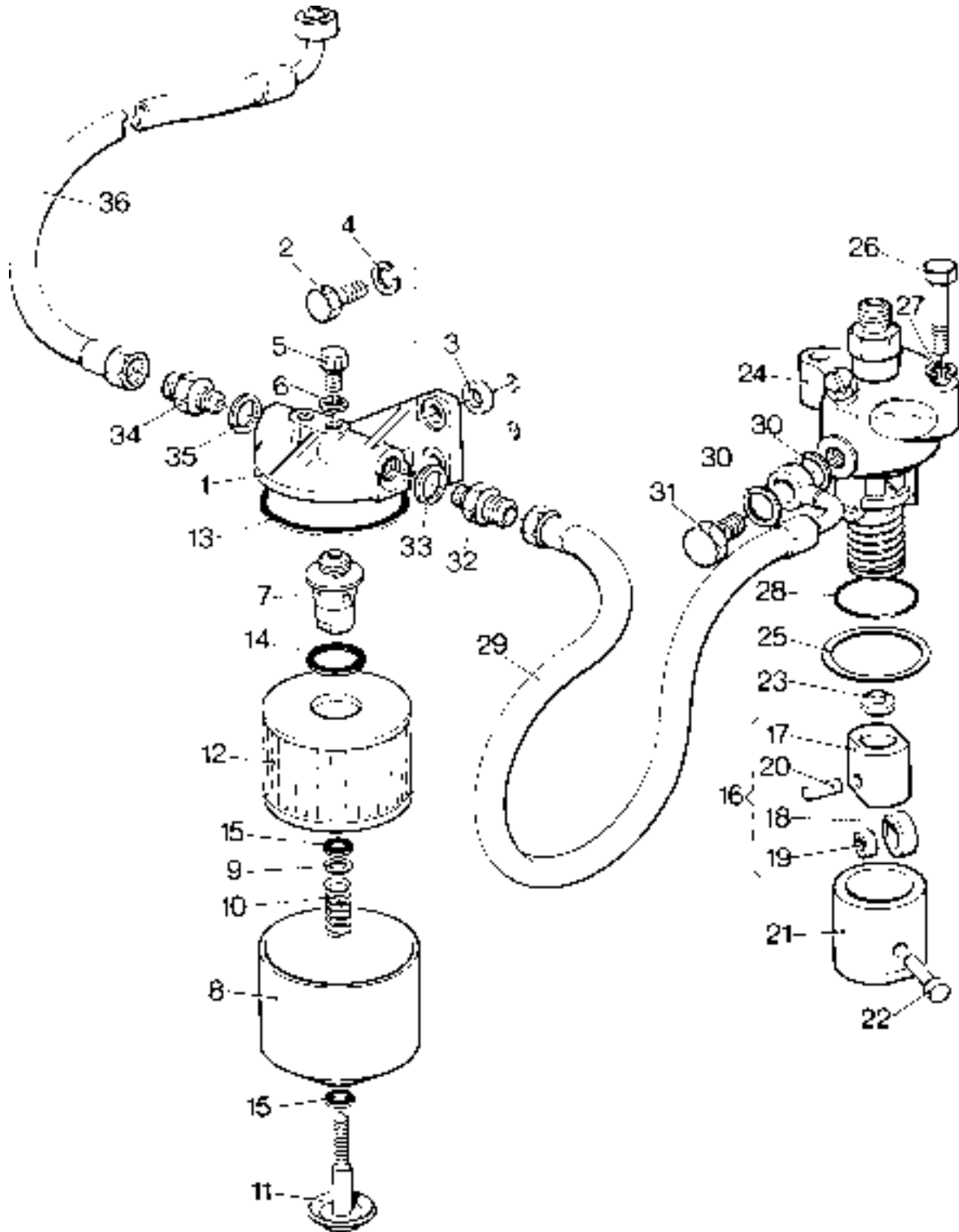

Fuel Filter and Pump

Illustration T15 No. Description	Part Number	TS/TR			Remarks
		1	2	3	
1 Fuel Filter	201-44580	1	1	1	Replaced by later Agglomerator
2 Element Kit	351-29760	1	1	1	
- Agglomerator - Later Type	750-14120	1	1	1	Replaces Fuel Filter 201-44580
Element Kit	751-18100	1	1	1	
3 Setscrew - M8 x 20mm	272-00039	2	2	2	
4 Washer	027-00082	2	2	2	Replaces 272-00751
5 Union	202-42370	2	2	2	Replaces Blanking Plug 354-28530
6 Ball	202-32120	2	2	2	Replaces Washer 201-41640
7 Union	202-42370	1	1	1	Replaces 354-28380, see Notes:
8 Olive	601-38360	1	1	1	
9 Non-return Valve	572-10611	1	1	1	Replaces 352-28740
10 Copper Washer	354-26310	2	2	2	
11 Union	202-42371	1	1	1	
12 Olive	351-21640	1	1	1	
13 Fuel Pipe - TS/TR1	201-46300	1	-	-	
- Fuel Pipe - TS/TR2	202-46300	-	1	-	Replaces 202-37511 & 202-32161
- Fuel Pipe - TS/TR3	203-46300	-	-	1	Replaces 203-32161 & 203-32161
14 Copper Washer	616-01608	2	4	6	
15 Swivel Union Plug	202-34000	1	2	3	
16 Fuel Pump Tappet Guide	201-30120	1	2	3	
17 Locating Screw	201-30630	-	2	3	
- Locating Pin	201-39680	1	-	-	
18 Copper Washer	616-01608	-	2	3	
- Tappet Assembly	570-30770	1	2	3	
19 Tappet		1	2	3	
20 Pin	601-21410	1	2	3	
21 Roller	601-21390	1	2	3	
22 Bush	601-21400	1	2	3	
23 Cap	201-30140	1	2	3	
24 Fuel Pump	201-31305	1	2	3	Replaces 201-31303. See Note ¹
- Element	660-14260	1	2	3	See Note ¹
- Delivery Valve	660-14270	1	2	3	See Note ¹
- Vent Screw	3/485A	1	2	3	See Note ¹
25 Shim - 0,127mm	201-45961				Use as required, See Note ²
- Shim - 0,762mm	201-45962				Use as required, See Note ²
- Shim - 1,016mm	201-45963				Use as required, See Note ²
- Shim - 1,270mm	201-45964				Use as required, See Note ²
26 Bolt - M6 x 45mm	272-00165	2	4	6	
27 Spring Washer	272-00070	2	4	6	
28 'O' Ring	601-20691	1	2	3	
Accessory Kit Code FF - TS/TR2,3	570-34650	-	1	1	Fuel Agglomerator Kit. Contains all items listed below and Note
29 Fuel Agglomerator - Early Type	366-07180	-	1	1	Replaces fuel filter. See above kit and Note
- Element Kit	351-29760	-	1	1	
30 Copper Washer	354-26310	-	2	2	
31 Union	202-42370	-	2	2	Replaces Blanking Plug 354-28530
32 Ball	202-32120	-	2	2	Replaces Washer 201-41640

Notes:

- The current pump being fitted is Lucas Dizel. Before replacing any other pump refer to Lister Petter or a distributor.
- The round type fuel timing shims were first fitted on the following engines and the round and sickle types must not be mixed on the same pump.
4000297TS2 4000135TR2
4000223TS3 4000039TR3
The sickle type fuel timing shim were:
0,127mm 602-21870 0,508mm 602-21872
0,254mm 602-21871 0,762mm 602-21873

Illustration T15

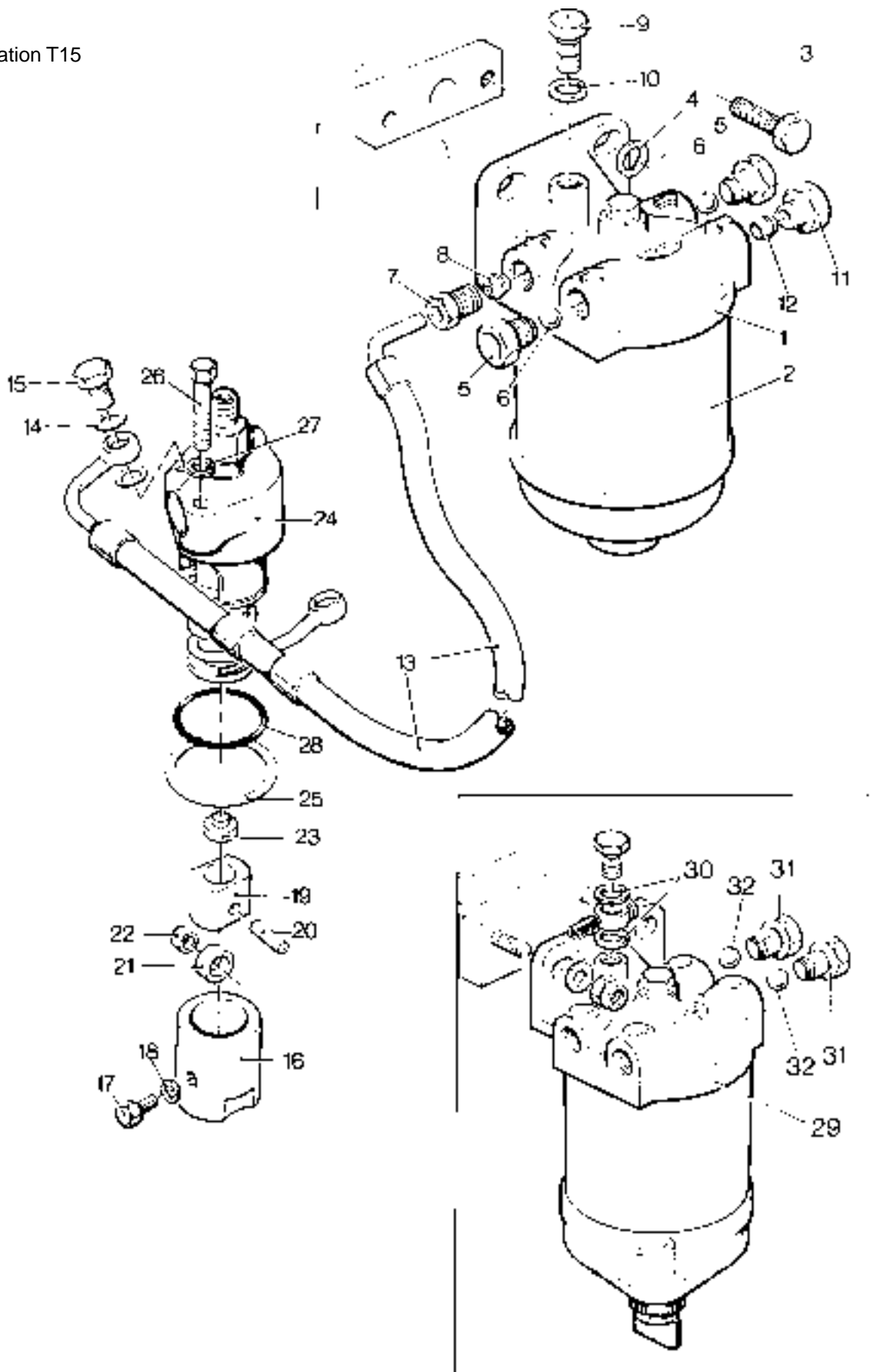

Fuel Injector

Illustration T17 No.	Description	Part Number	TS/TR			Remarks
			1	2	3	
1	Pump to Injector Pipe	201-31474	1	2	3	
2	Clamp	351-55890	1	2	3	
3	Capscrew	272-00257	1	2	3	
-	Fuel Injector - TS	201-47072	1	2	3	See Note ¹
-	Nozzle	201-47092	1	2	3	See Note ²
4	Fuel Injector - TR	201-47042	1	2	3	See Note ¹
5	Nozzle	201-47062	1	2	3	See Note ²
6	Washer	351-40230	1	2	3	
7	Copper Washer	352-29370	1	2	3	
8	Injector Union	202-38500	1	2	3	
-	Leak-off Pipe Assembly	201-46591	1	-	-	TS1 Build 102
9	Tee Piece	751-13100	1	2	3	Replaces 202-38460
10	Hose	027-07396	-	3	3	Replaces 202-41260
11	Hose	202-48120	1	2	3	Replaces 202-41260
12	Hose	202-42480	1	1	1	Not TS1 Build 16-18, 102 and TR1 Build 16. See Note ³ .
-	Hose	027-07400	1	-	-	TS1 Builds 16-18, 102, TR1 Build 16
13	Rubber Boot	202-41270	1	1	1	
14	Connection	202-38490	1	1	1	See Note ³
15	Non-return Valve Assembly	572-10611	1	1	1	
16	Washer	354-26310	2	2	2	

Notes:

1. This Injector replaces all previous Injectors.
It is recommended that fuel injectors are fitted as a complete set.
If in doubt, refer to any Lister-Petter Diesel Distributor
2. TS - For injector 201-90463 use nozzle 201-81395
TR - For injector 202-36730 use nozzle 202-36720
NOZZLES ARE NOT INTERCHANGEABLE
3. Hose 202-42480 (number 12) replaces Hose 201-42620 on TS/TR1 (shown on illustration as letter A) and
Connection 202-38490 (number 14) replaces Connection 201-42600 on TS/TR1 (shown on illustration as letter B).

Illustration T17

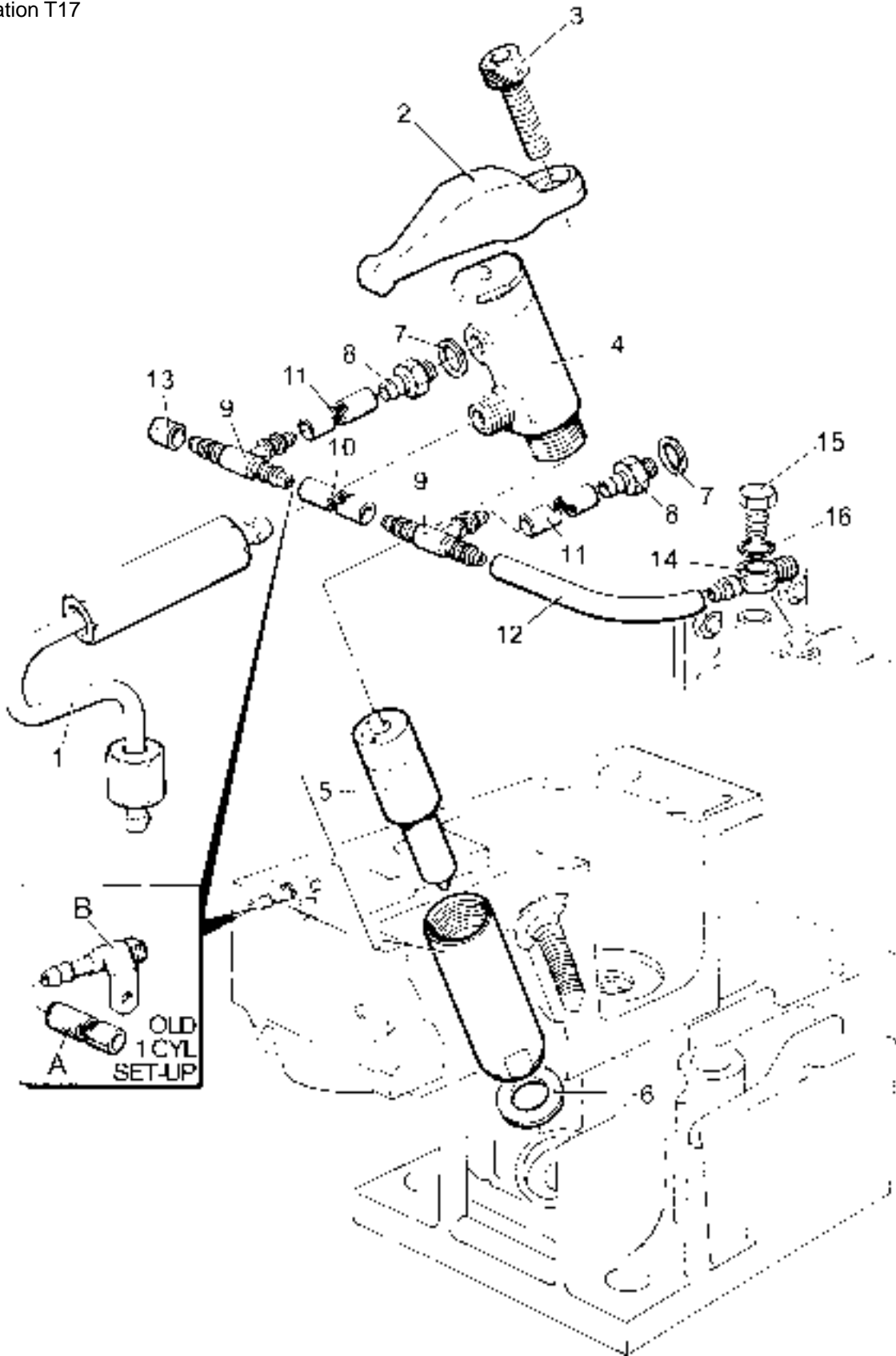

Steel Fuel Pipes

Illustration T390 No.	Description	Part Number	TS/TR			Remarks
			1	2	3	
	Accessory Kit Code FH - TS/TR2	570-33020	-	1	-	
	Accessory Kit Code FH - TS/TR3	570-33030	-	-	1	
-	Leak-off Pipe - TS1	201-44750	1	-	-	
1	Leak-off Pipe - TS/TR2	202-38740	-	1	-	See Note ¹
-	Leak-off Pipe - TS/TR3	203-38740	-	-	1	See Note ²
2	Swivel Union Plug	601-36100	1	2	3	
3	Copper Washer	352-29370	2	4	6	
4	Grommet	202-41320	1	2	3	
5	Non-return Valve	572-10611	1	1	1	
6	Copper Washer	354-26310	2	2	2	
-	Filter to Pump Pipe - TS1	201-44721	1	-	-	
7	Filter to Pump Pipe - TS/TR2	202-38702	-	1	-	See Note ³
-	Filter to Pump Pipe - TS/TR3	203-38702	-	-	1	See Note ³
8	Copper Washer	616-01608	2	4	6	
9	Swivel Union Plug	202-34000	1	2	3	
10	Union - TS/TR2,3	202-42370	-	1	1	
11	Olive	601-38360	-	1	1	
-	Swivel Union Plug - TS/TR1	201-45710	1	-	-	Not used on Build 40
-	Copper Washer - TS/TR1	201-41640	2	-	-	Not used on Build 40

Notes:

1. Replaces 202-31981 (2 off) and 202-34290 from engine no. 3501131TS2
2. Replaces 202-31981 (3 off) and 203-34290 from engine no. 3500854TS3
3. 202-38702 and 203-38702 replaces 202-38700, 202-38701, 203-38700 and 203-38701, and Union 202-42370 and Olive 201-45710 are also supplied

Illustration T390

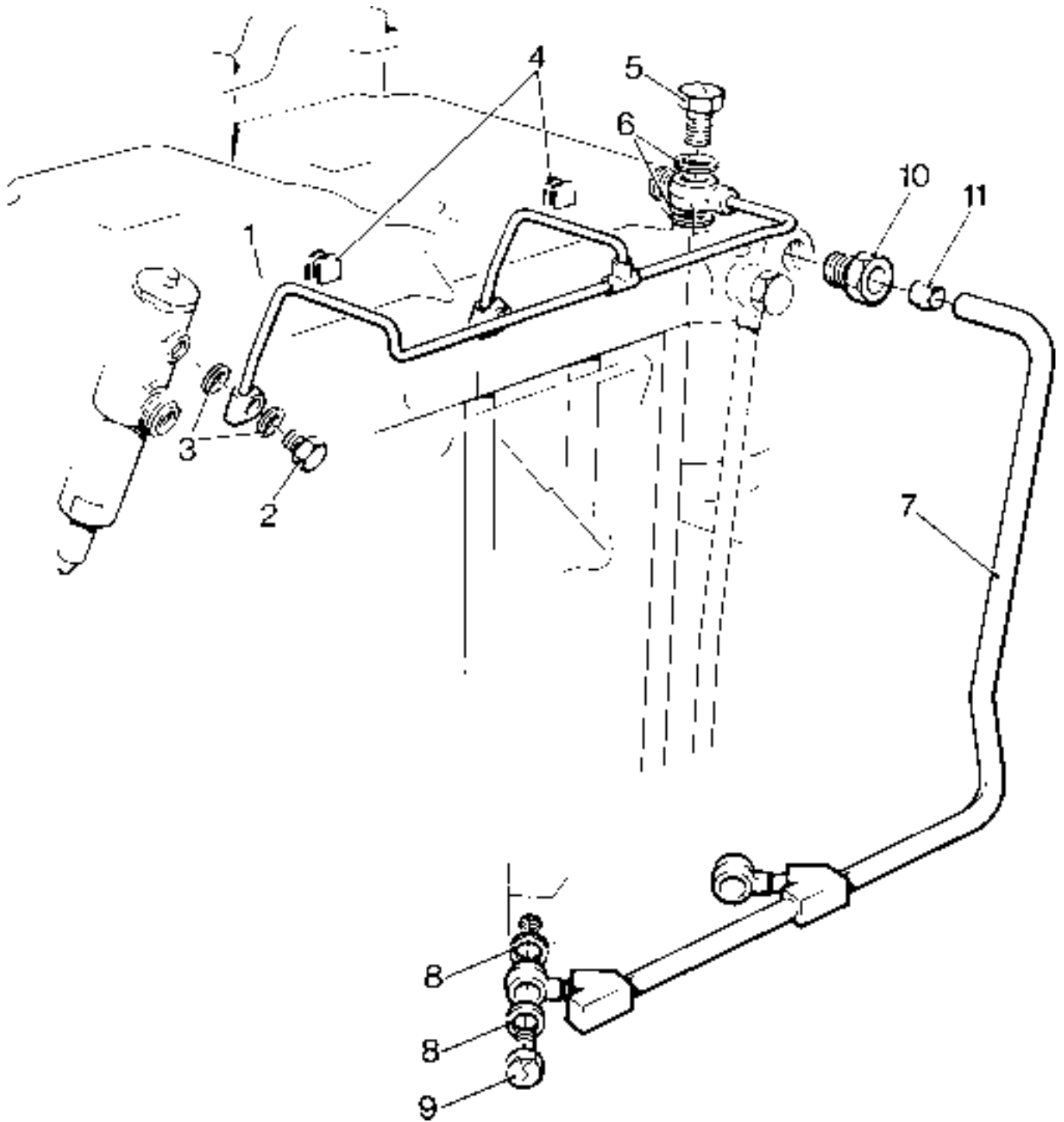

Fuel Tank - 8,25 litre

Illustration T260 No.	Description	Part Number	TS/TR			Remarks
			1	2	3	
	Accessory Kit Code FA	570-32791	1	-	-	
1	Fuel Tank	601-37862	1	-	-	
2	Stay	201-38070	1	-	-	
3	Setscrew - M6 x 14mm	272-00034	1	-	-	Replaces 272-00033
4	Washer	272-00364	1	-	-	
5	Spring Washer	272-00070	1	-	-	
6	Nut	272-00002	1	-	-	
7	Spacer	027-07804	1	-	-	
8	Bolt - M6 x 30mm	272-00035	1	-	-	
9	Spring Washer	272-00070	1	-	-	
10	Washer	202-80680	3	-	-	
11	Setscrew - M8 x 25mm	272-00040	3	-	-	
12	Spring Washer	272-00071	3	-	-	
13	Filler Cap	366-08136	1	-	-	Replaces 366-00091
-	Joint	027-06151	1	-	-	Only used with 366-00091
14	Grommet	601-33740	1	-	-	
15	Leak-off Pipe	201-41760	1	-	-	
16	Hose	202-41280	1	-	-	
17	Setscrew - M6 x 12mm	272-00032	1	-	-	
18	Spring Washer	272-00070	1	-	-	
19	Plug	318982	1	-	-	
20	Washer	601-43141	1	-	-	
21	Fuel Filter Element	330573	1	-	-	
22	Seal	031-61533	1	-	-	Replaces 013-22350
23	Fuel Pipe Union	601-42610	1	-	-	
24	Fuel Pipe	366-07607	1	-	-	
25	Copper Washer	616-01608	2	-	-	
-	Cylinder Head Cover	570-30752	1	-	-	Replaces 570-30753

Illustration T260

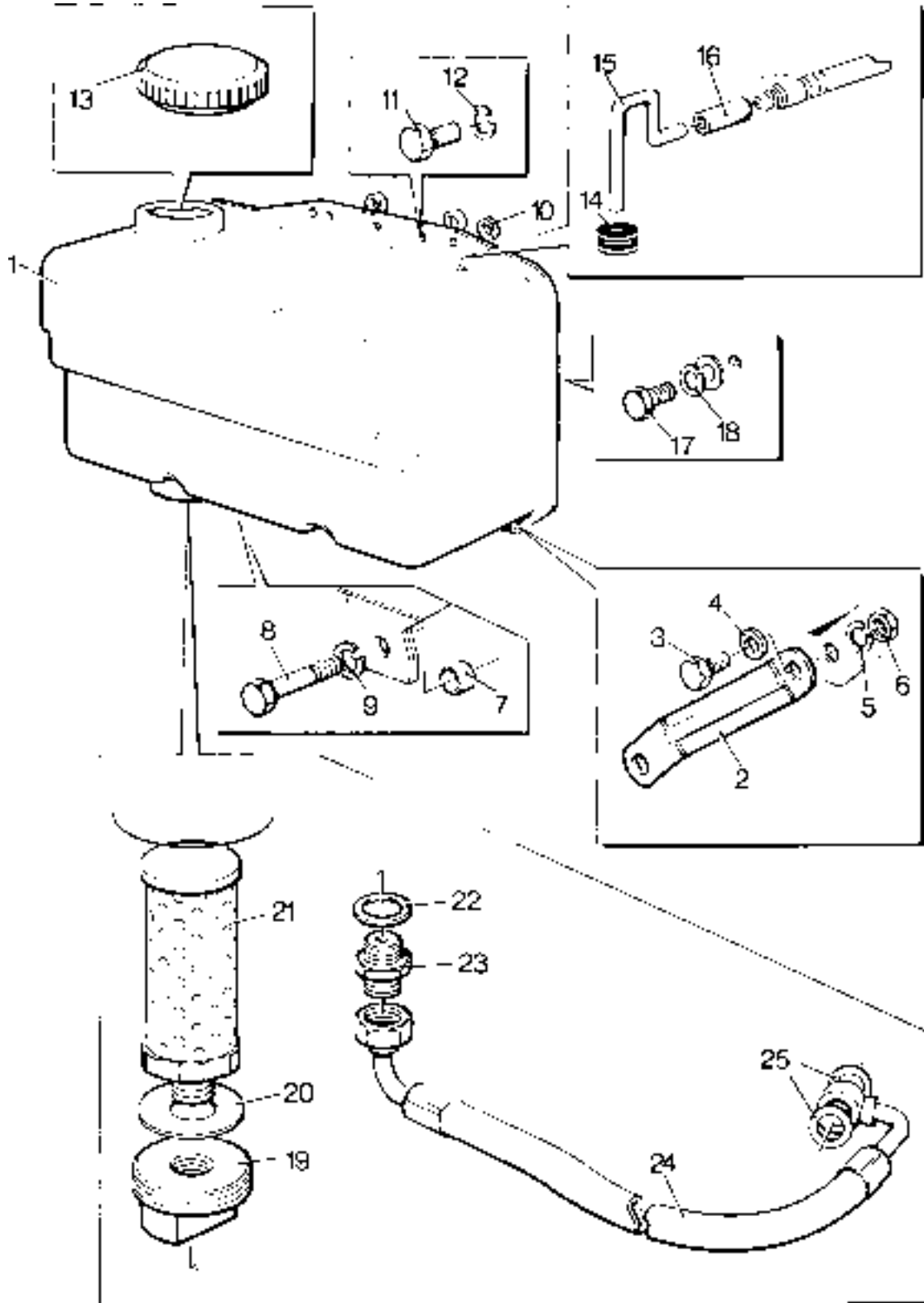

Fuel Tank - 13,5 litre - Early Engines

Illustration T325 No.	Description	Part Number	TS/TR			Remarks
			1	2	3	
1	Fuel Tank	201-30822	1	1	1	Replaces 201-30821
2	Setscrew - M8 x 25mm	272-00040	4	4	4	
3	Spring Washer	272-00071	4	4	4	
4	Setscrew - M8 x 20mm	272-00039	1	1	1	
5	Nut	272-00003	1	1	1	
6	Spacer	201-42450	1	1	1	
7	Stay	201-31422	1	1	1	
8	Filler Cap	366-08136	1	1	1	Replaces 366-00091
-	Joint	027-06151	1	1	1	Only used with 366-00091
9	Fuel Filter Bracket	601-31732	1	1	1	
10	Bleed Screw	601-21620	2	2	2	
11	Washer	601-32470	2	2	2	
-	Union Adaptor - TS/TR1	602-38250	1	-	-	
12	Union Adaptor- TS/TR2,3	202-37950	-	1	1	
13	Copper Washer	354-26310	1	1	1	
14	Fuel Filter Adaptor	601-34690	1	1	1	
-	Bowl and Element Assembly	570-31260	1	1	1	
15	Filter Bowl		1	1	1	
16	Locating Washer		1	1	1	
17	Spring		1	1	1	
18	Bolt		1	1	1	
19	Element Kit	203-32470	1	1	1	
20	Sealing Ring		1	1	1	
21	Sealing Ring		1	1	1	
22	Sealing Ring		2	2	2	
23	Mounting Plate	201-44930	1	1	1	
24	Setscrew - M8 x 20mm	272-00039	1	1	1	
25	Washer	027-00082	1	1	1	
26	Spring Washer	272-00071	1	1	1	
27	Nut	272-00003	1	1	1	
28	Setscrew - M6 x 20mm	272-00117	2	2	2	
29	Washer	272-00364	2	2	2	
30	Spring Washer	272-00070	2	2	2	
31	Nut	272-00002	2	2	2	
32	Grommet	601-33740	1	1	1	
33	Fuel Leak-off Pipe	366-07117	1	1	1	
34	Hose	202-41280	1	1	1	
35	Rubber Boot	202-41270	1	1	1	
-	Setscrew - M6 x 12mm	272-00032	1	-	-	
-	Setscrew - M8 x 20mm	272-00039	1	-	-	
-	Bolt - M8 x 30mm	272-00041	1	-	-	
-	Spacer	201-41750	1	-	-	
36	Bolt - M8 x 35mm	272-00042	-	1	1	
37	Spacer	201-42570	-	1	1	
38	Spring Washer	272-00071	1	1	1	
-	Fuel Pipe - TS/TR1	570-35700	1	-	-	Replaces 201-38940
39	Fuel Pipe - TS/TR2	202-34070	-	1	-	
-	Fuel Pipe - TS/TR3	203-34070	-	-	1	
40	Copper Washer	616-01608	2	4	6	
41	Fuel Pipe	366-07845	1	1	1	
42	Union Nut	601-38370	1	1	1	
43	Olive	601-38360	1	1	1	
44	Fuel Filter Union	602-38800	1	1	1	
45	Copper Washer	354-26310	1	1	1	
-	Cylinder Head Cover - TS/TR1	570-30753	1	-	-	See Note
-	Cylinder Head Cover - Gear End TS/TR2,3	570-30752	-	1	1	See Note
-	Joint	201-30805	1	1	1	See Note
-	Flywheel End Side Shield	201-39850	-	1	1	See Note
-	Setscrew - M8 x 12mm	272-00166	-	1	1	See Note
-	Spring Washer	272-00071	-	1	1	See Note

Note:

These items must be fitted to engine to enable fuel tank mounting.

Illustration T325

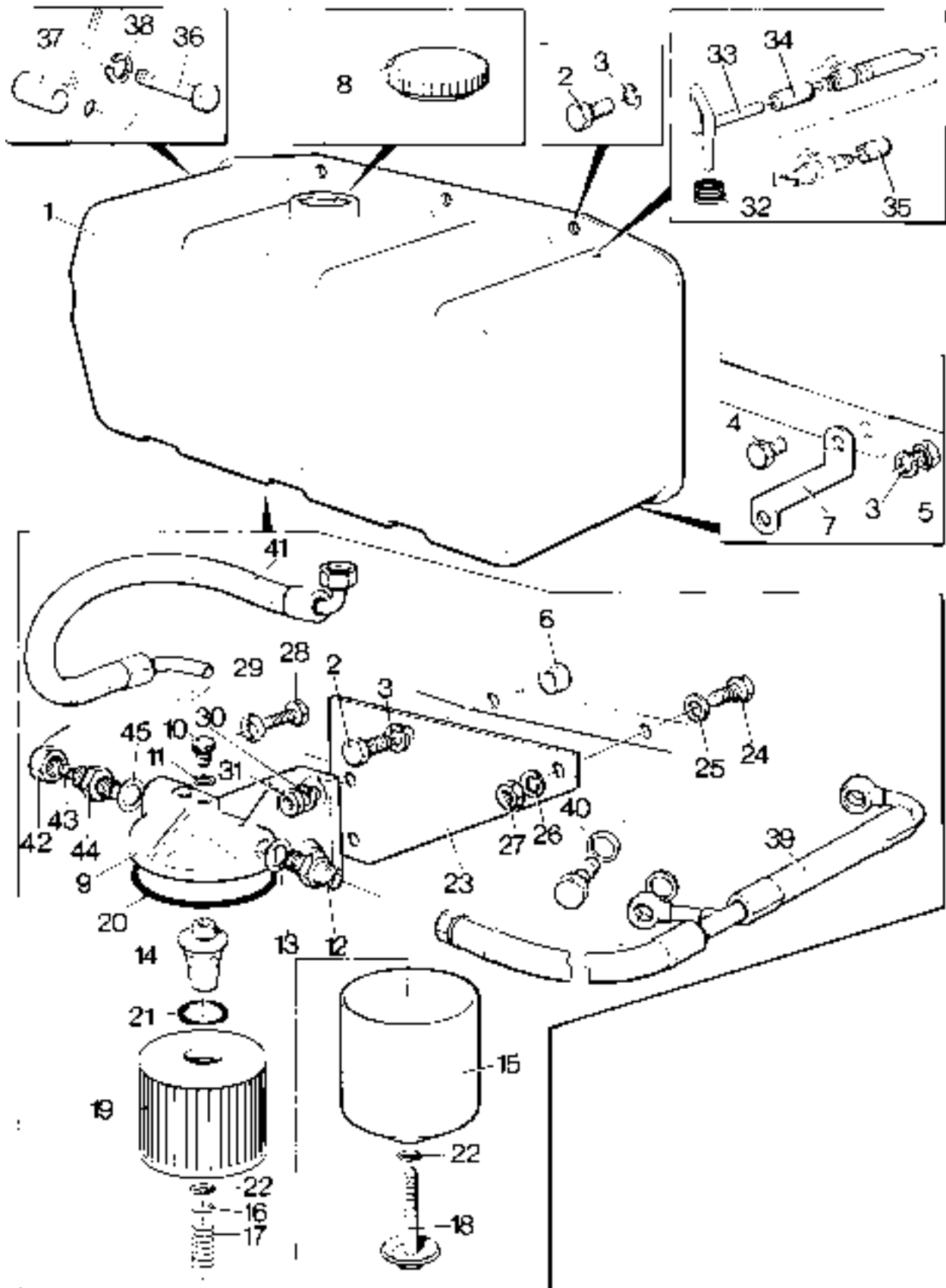

Fuel Tank - 13,5 litre - TS1,2,3 - Later Engines

Illustration T426 No. Description	Part Number	TS			Remarks
		1	2	3	
Accessory Kit Code FB - TS/TR1	570-35691	1	-	-	
Accessory Kit Code FB - TS/TR2	570-35692	-	1	-	
Accessory Kit Code FB - TS/TR3	570-35693	-	-	1	
1 Fuel Tank Assembly	201-30822	1	1	1	
2 Setscrew - M8 x 25mm	272-00040	4	4	4	
3 Spring Washer - M8	272-00071	7	7	7	
4 Screw - M8 x 20mm	272-00039	2	2	2	
5 Nut - M8	272-00003	4	4	4	
6 Spacer	201-42450	1	1	1	
7 Stay	201-31422	1	1	1	
8 Filler Cap	366-08136	1	1	1	
9 Bracket	201-46830	1	1	1	
10 Bolt - M8 x 30mm	272-00041	3	3	3	
11 Washer - 5/16"	027-00082	2	2	2	
12 Plug - M10	272-00370	1	1	1	
13 Copper Washer	354-26310	1	1	1	
14 Fuel Pipe Assembly - Tank to Filter	201-46880	1	1	1	
- Fuel Pipe Assembly - Filter to Engine - TS1	201-46800	1	-	-	
15 Fuel Pipe Assembly - Filter to Engine - TS2	202-46800	-	1	-	
- Fuel Pipe Assembly - Filter to Engine - TS3	203-46800	-	-	1	
16 Copper Washer - 5/16"	616-01608	2	4	6	
17 Grommet	601-33740	1	1	1	
18 Leak Off Pipe	366-07117	1	1	1	
19 Hose	202-41280	1	1	1	
20 Rubber Boot	202-41270	1	1	1	
21 Spacer	201-42570	1	1	1	
22 Bolt - M8 x 35mm	272-00042	1	1	1	
- Cylinder Head Cover Assembly	570-30752	1	1	1	See Note ¹
- Joint - Cylinder Head Cover	201-30805	1	1	1	See Note ¹
- Side Shield Assembly	201-42760	1	1	1	See Note ¹
- Screw - M8 x 12mm	272-00166	1	1	1	See Note ¹
- Washer - 5/16"	027-00082	1	1	1	See Note ¹
30 Fuel Filter	201-44580	1	1	1	Replaced by Agglomerator
- Element Kit	351-29760	1	1	1	
- Agglomerator	750-14120	1	1	1	Replaces Fuel Filter 201-44580. See Note ²
- Element Kit	751-18100	1	1	1	See Note ²
31 Ball	202-32120	2	2	2	Replaces Washer 201-41640
32 Union	202-42370	2	2	2	Replaces Blanking Plug 354-28530
33 Tube Nut	202-42370	2	2	2	See Note ²
34 Olive	601-38360	2	2	2	See Note ²
35 Washer - 5/16"	027-00082	2	2	2	See Note ²
36 Spring Washer - M8	272-00071	2	2	2	See Note ²

Notes:

1. These items must be fitted to engine to enable fuel tank mounting.
2. Items marked are NOT part of this Accessory Kit. They are part of the Basic Engine Build, and are labelled only for information.

25 Litre Fuel Tank - Loose

Not Illustrated Description	Part Number	TS/TR			Remarks
		1	2	3	
Accessory Kit Code FD	570-32641	1	1	1	
Fuel Tank Assembly	202-34580	1	1	1	
Filler Cap	366-08136	1	1	1	

Illustration T426

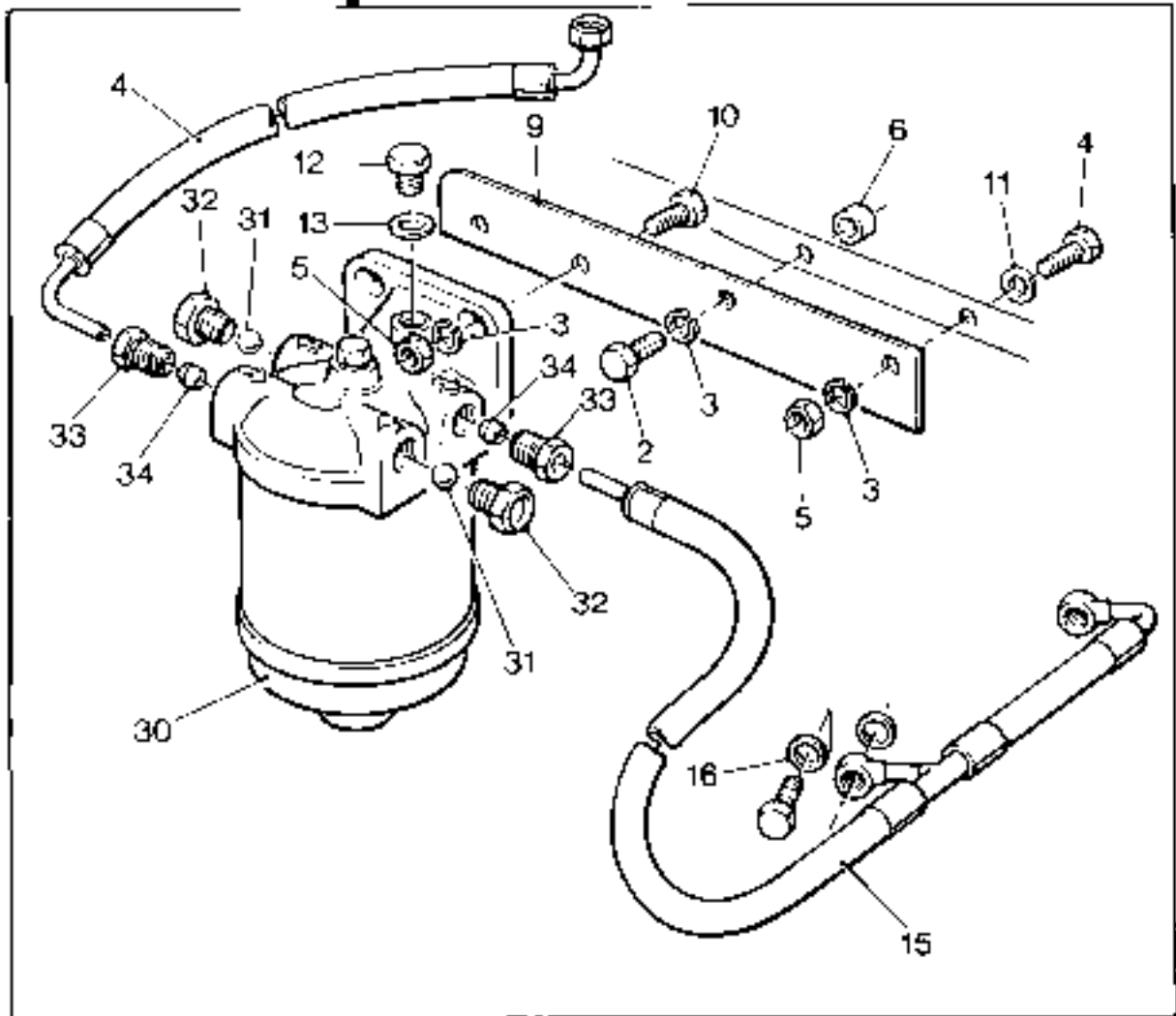
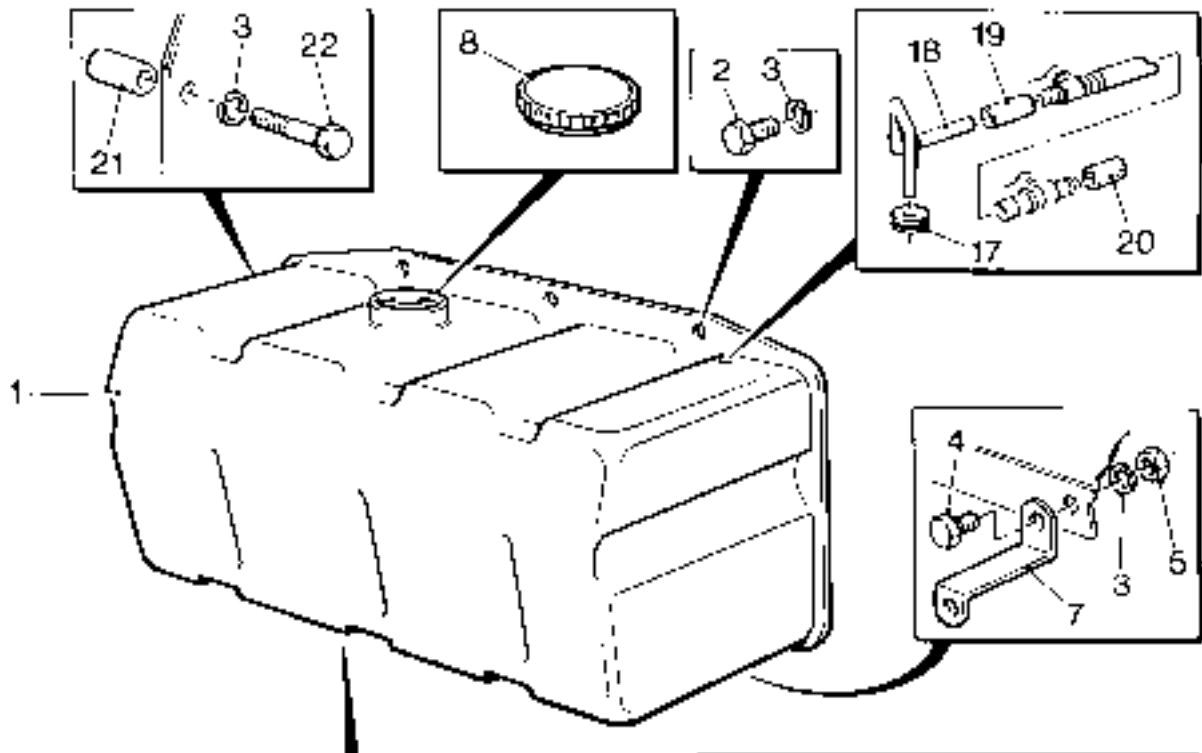

Inlet and Exhaust Manifolds

Not TS1 Builds 16, 101, 102, 103

Not TR1 Builds 16

Illustration T185

No.	Description	Part Number	TS/TR			Remarks
			1	2	3	
-	Inlet Manifold - TS/TR1	201-37852	1	-	-	Replaces 201-37851
1	Inlet Manifold - TS/TR2	202-31003	-	1	-	
-	Inlet Manifold - TS/TR3	203-31003	-	-	1	
-	Inlet Manifold - TS/TR1	201-37861	1	-	-	Used with oil bath air cleaner 203-11422. Available as kit AS (570-32760) with no's 8 & 3
-	Inlet Manifold - TS/TR2	202-45880	-	1	-	Used with oil bath air cleaner 203-11422 and TR2 Build 101
-	Inlet Manifold - TS/TR3	203-45880	-	-	1	TR3 up to 2000 r/min. Used with oil bath air cleaner 203-11422.
-	Inlet Manifold - TS/TR2	202-31004	-	1	-	Used with cyclonic air cleaner 366-08108. Available as kit AT (570-41991) with Joint (no. 3)
-	Inlet Manifold - TS/TR3	202-31005	-	-	1	Used with cyclonic air cleaner 366-08108. Available as kit AT (570-41992) with Joint (no. 3)
-	Inlet Manifold with Gear End Flange - TS/TR2,3	202-31001	-	1	1	Available as kit AX with Joint (no. 3). TS/TR2 = 570-32560 TS/TR3 = 570-32570
-	Remote Air Cleaner Adaptor - TS/TR2,3	366-08094	-	1	1	Spigot diameter 21/4" (57,1mm) Available as kit AP (570-41730)
-	Exhaust Manifold - TS/TR1	201-37842	1	-	-	
2	Exhaust Manifold - TS/TR2	202-31021	-	1	-	
-	Exhaust Manifold - TS/TR3	203-31021	-	-	1	
3	Joint	201-33420	2	4	6	One fitted each side of the air cowling
-	Manifold Top Stud M8 x 45mm - TS/TR1	272-00301	2	-	-	One fitted on TR1 Build 100
4	Manifold Top Stud M8 x 40mm - TS/TR2,3	272-00307	-	4	6	Two fitted on TR2 Build 101
-	Clamping Washer - TS/TR1	201-34760	2	-	-	
5	Clamping Washer - TS/TR2,3	202-80680	-	4	6	Two fitted on TR2 Build 101
6	Spring Washer	272-00071	2	4	6	Two fitted on TR2 Build 101
7	Nut	272-00380	1	2	3	
-	Bottom Manifold Stud - M6 x 85mm	272-00357	1	-	-	
8	Bottom Manifold Stud - M6 x 30mm	272-00304	2	4	6	One fitted on TR1 Build 100
9	Spring Washer	272-00070	2	4	6	
10	Nut	272-00379	2	4	6	
11	Setscrew - M8 x 10mm	272-00239	-	1	1	
12	Washer	616-01608	-	1	1	
13	Inlet Manifold Adaptor - TS/TR2,3	202-38721	-	1	1	For Cooper air cleaner
14	Joint	202-33231	-	1	1	Replaces 202-33230
15	Stud	272-00108	-	2	2	
16	Nut	272-00003	-	2	2	
17	Spring Washer	272-00071	-	2	2	
-	Stud	272-00789	1	-	-	TR1 Build 100 only

Illustration T185

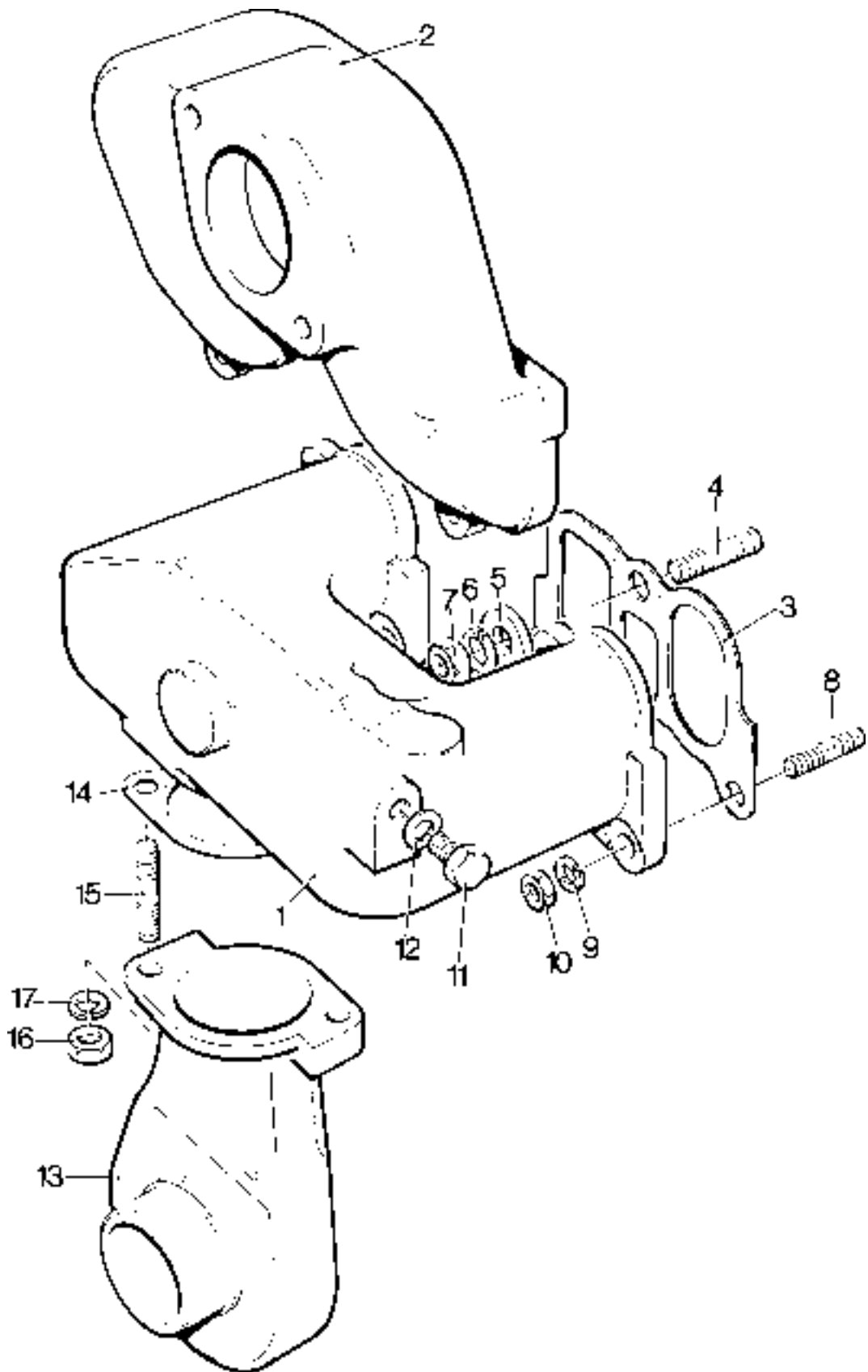

Inlet and Exhaust Manifolds

TS1 Builds 16, 101, 102, 103

TR1 Build 16

Illustration T165

No.	Description	Part Number	TS/TR			Remarks
			1	2	3	
1	Inlet and Exhaust Manifold	201-41552	1	-	-	Replaces 201-41551
2	Joint.....	201-33420	1	-	-	
3	Stud - M8 x 100mm	272-00366	1	-	-	
4	Spring Washer	272-00071	1	-	-	
5	Nut.....	272-00380	1	-	-	Replaces 272-00011
6	Stud - M6 x 35mm	272-00304	2	-	-	Replaces 272-00334
7	Spring Washer	272-00070	2	-	-	
8	Nut.....	272-00379	2	-	-	Replaces 201-35070

Illustration T165

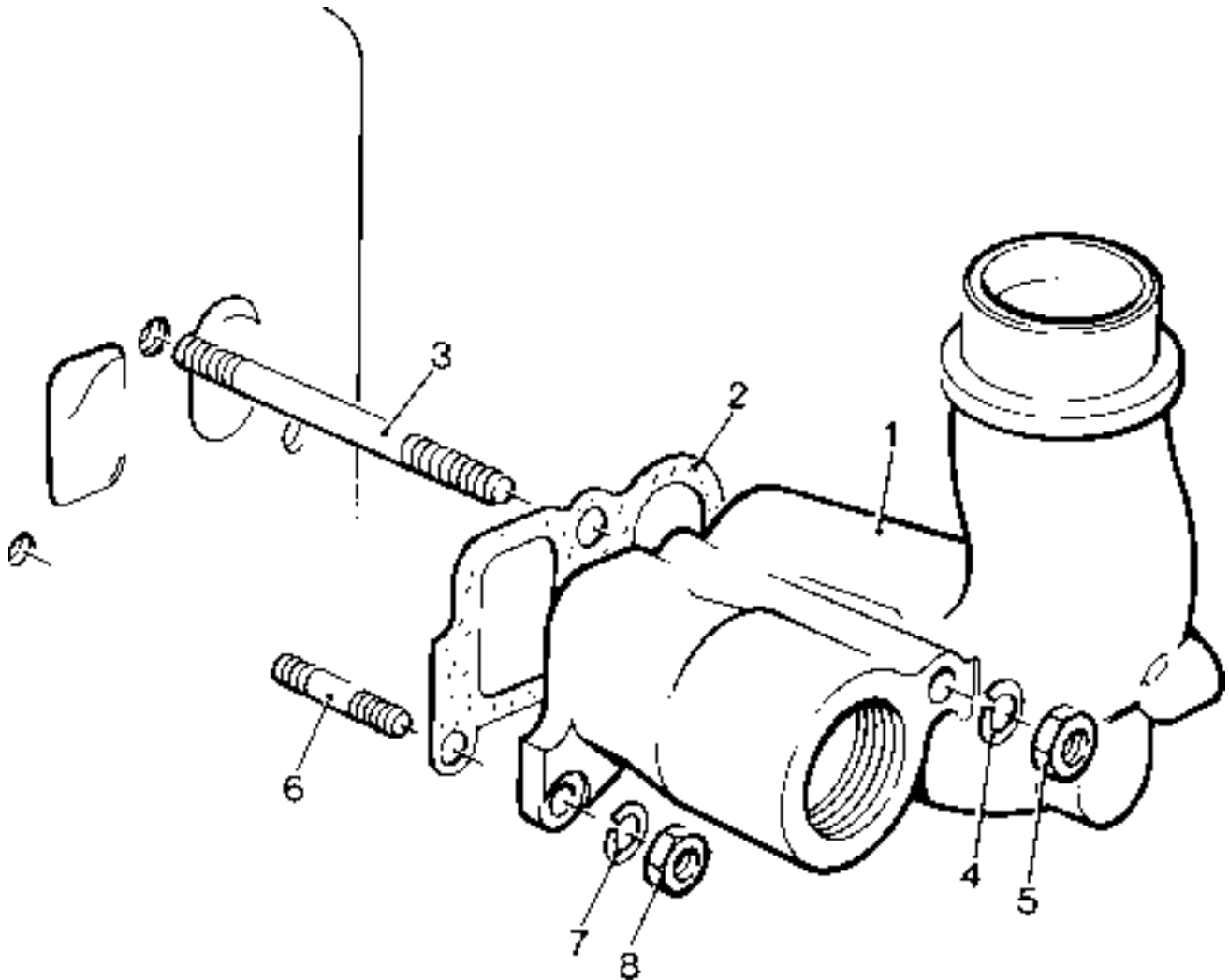

Vertical Outlet Exhaust Manifold Adaptor

Not Illustrated Description	Part Number	TS/TR			Remarks
		1	2	3	
Accessory Kit Code NG - TS/TR1	570-32980	1	-	-	
Accessory Kit Code NG - TS/TR2,3	570-31980	-	1	1	
Adaptor - TS/TR1	202-31031	1	-	-	
Adaptor - TS/TR2,3	366-06969	-	1	1	
Joint	366-01287	2	2	2	Replaces 757-15750
Bolt - M10 x 35mm - TS/TR1	272-00168	2	-	-	
Nut - TS/TR1	272-00012	2	-	-	
Setscrew - M10 x 30mm - TS/TR2,3	272-00080	-	2	2	
Spring Washer	272-00072	2	2	2	

Horizontal Outlet Exhaust Manifold Adaptor

Not Illustrated Description	Part Number	TS/TR			Remarks
		1	2	3	
Accessory Kit Code NJ - TS/TR2,3	570-31990	-	1	1	
Exhaust Bend	202-31031	-	1	1	
Joint	366-01287	-	2	2	Replaces 757-15750
Setscrew - M10 x 30mm	272-00080	-	2	2	
Spring Washer	272-00072	-	2	2	

1 1/2" Outlet Flange Exhaust Manifold Adaptor

Not Illustrated Description	Part Number	TS/TR			Remarks
		1	2	3	
Accessory Kit Code NF - TS/TR1	570-32970	1	-	-	
Accessory Kit Code NF - TS/TR2,3	570-31970	-	1	1	
Exhaust Flange - 1 1/2"	010-21801	1	1	1	
Bolt - M10 x 45mm - TS/TR1	272-00213	2	-	-	
Brass Nut	272-00012	2	-	-	
Setscrew - M10 x 30mm - TS/TR2,3	272-00080	-	2	2	
Spring Washer	272-00072	2	2	2	
Joint	366-01287	1	1	1	Replaces 757-15750

Silencer Outlet Bend

Not Illustrated Description	Part Number	TS/TR			Remarks
		1	2	3	
Accessory Kit Code NH	570-32520	1	1	1	
Silencer Outlet Bend	202-36900	1	1	1	
Clamp	737-13060	1	1	1	

Heat Shield

Not Illustrated Description	Part Number	TS/TR			Remarks
		1	2	3	
Accessory Kit Code NM	570-41720	1	1	1	
Heat Shield	366-08148	1	1	1	
Clip	027-10021	2	2	2	

Medium Duty Silencer

Not Illustrated Description	Part Number	TS/TR			Remarks
		1	2	3	
Accessory Kit Code NA - TS/TR1	570-31170	1	-	-	
Accessory Kit Code NA - TS/TR2,3	570-31960	-	1	1	Includes code NJ in kit
Silencer - TS/TR1	201-37072	1	-	-	
Silencer - TS/TR2,3	203-32561	-	1	1	Replaces 203-32560
Adaptor - TS/TR3	202-31031	-	1	1	
Setscrew - M10 x 30mm	272-00080	2	4	4	
Spring Washer	272-00072	2	4	4	
Joint	366-01287	1	2	2	Replaces 757-15750
Accessory Kit Code NL - TS/TR1	570-13980	1	-	-	Build 16 only
Silencer Assembly	202-55190	1	-	-	Build 16

Heavy Duty Silencer (not engine mounted)

Not Illustrated Description	Part Number	TS/TR			Remarks
		1	2	3	
Accessory Kit Code NC	570-15780	1	1	1	Not Build 16
Silencer Assembly	027-06332	1	1	1	Not Build 16
Silencer Body	027-06320	1	1	1	
Flange	366-01265	2	2	2	
Joint	366-01266	1	1	1	
Screw - 1/2" UNF x 1 1/4"	270-00077	4	4	4	
Nut - 1/2" UNF	270-00006	4	4	4	
Spring Washer - 1/2" diameter	027-00394	4	4	4	

Heavy Duty Silencer - TS2,3

Illustration T411
No. Description

Part Number 1 2 3 Remarks

TS

No.	Description	Part Number	1	2	3	Remarks
	Accessory Kit Code NB	570-32400	-	1	1	Use with code AE or AX
1	Silencer	202-36742	-	1	1	
2	Stud - M10 x 70mm	272-00057	-	1	1	
3	Spacer	201-42830	-	2	2	
4	Spacer	201-42520	-	1	1	
5	Silencer Support Bracket	202-36891	-	1	1	
6	Joint	366-01287	-	1	1	
7	Silencer Outlet Bend	202-36900	-	1	1	
8	Clamp	737-13060	-	1	1	
9	Setscrew - M10 x 30mm	272-00080	-	2	2	
10	Spring Washer	272-00072	-	2	2	

Illustration T411

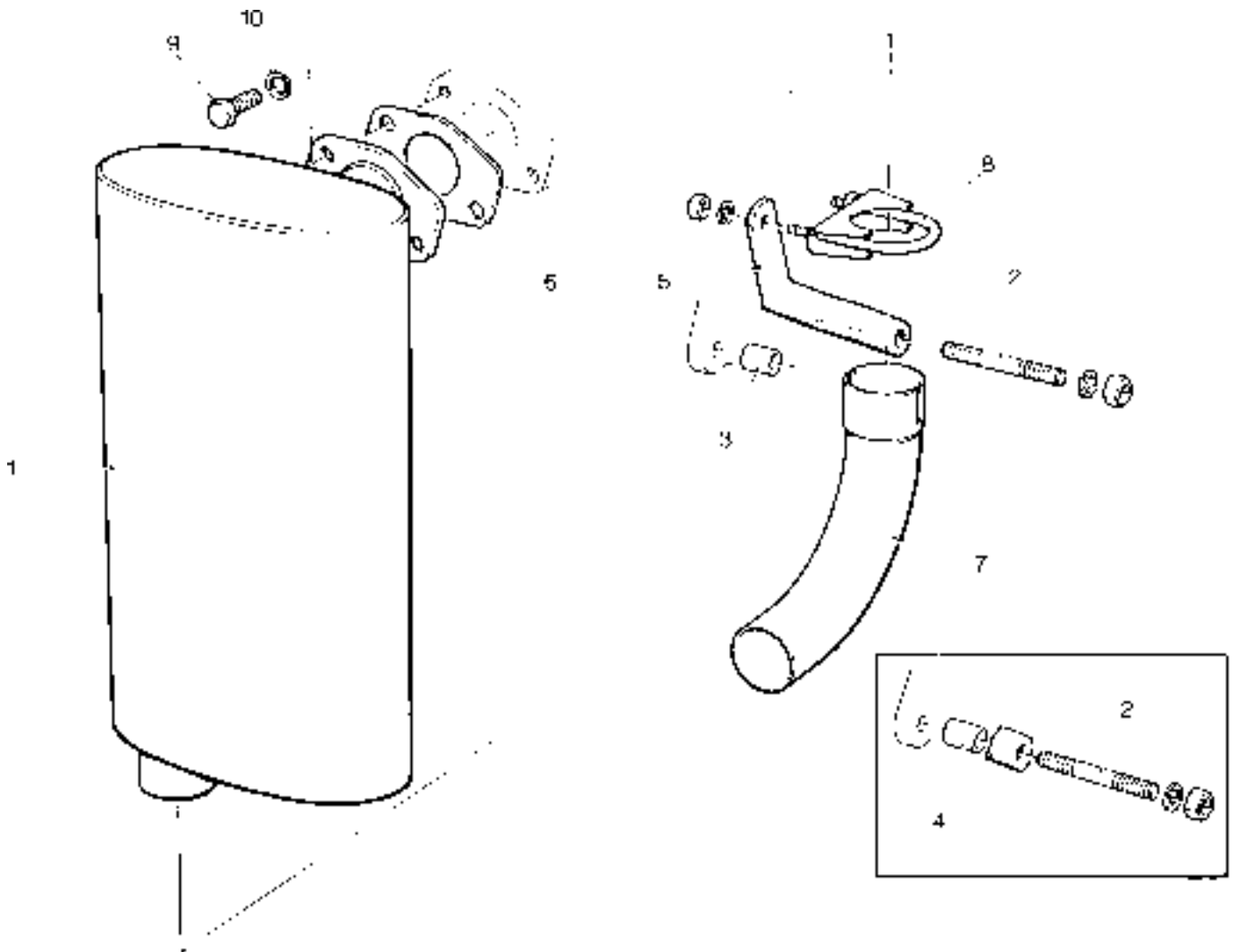

Flexible Exhaust Pipe (1 metre)

Illustration T118
No. Description

No.	Description	Part Number	TS/TR			Remarks
			1	2	3	
	Accessory Kit Code NE	570-32410	1	1	1	
1	Flexible Exhaust Pipe	366-08129	1	1	1	
2	Joint	366-01287	2	2	2	
3	Setscrew - M10 x 30mm	272-00080	2	2	2	
4	Spring Washer	272-00072	2	2	2	
5	Mating Flange	010-21801	2	2	2	
6	Bolt - $\frac{3}{8}$ "UNF x $1\frac{3}{4}$ "	270-00221	4	4	4	
7	Spring Washer	027-00393	4	4	4	
8	Nut	270-00004	4	4	4	

Illustration T118

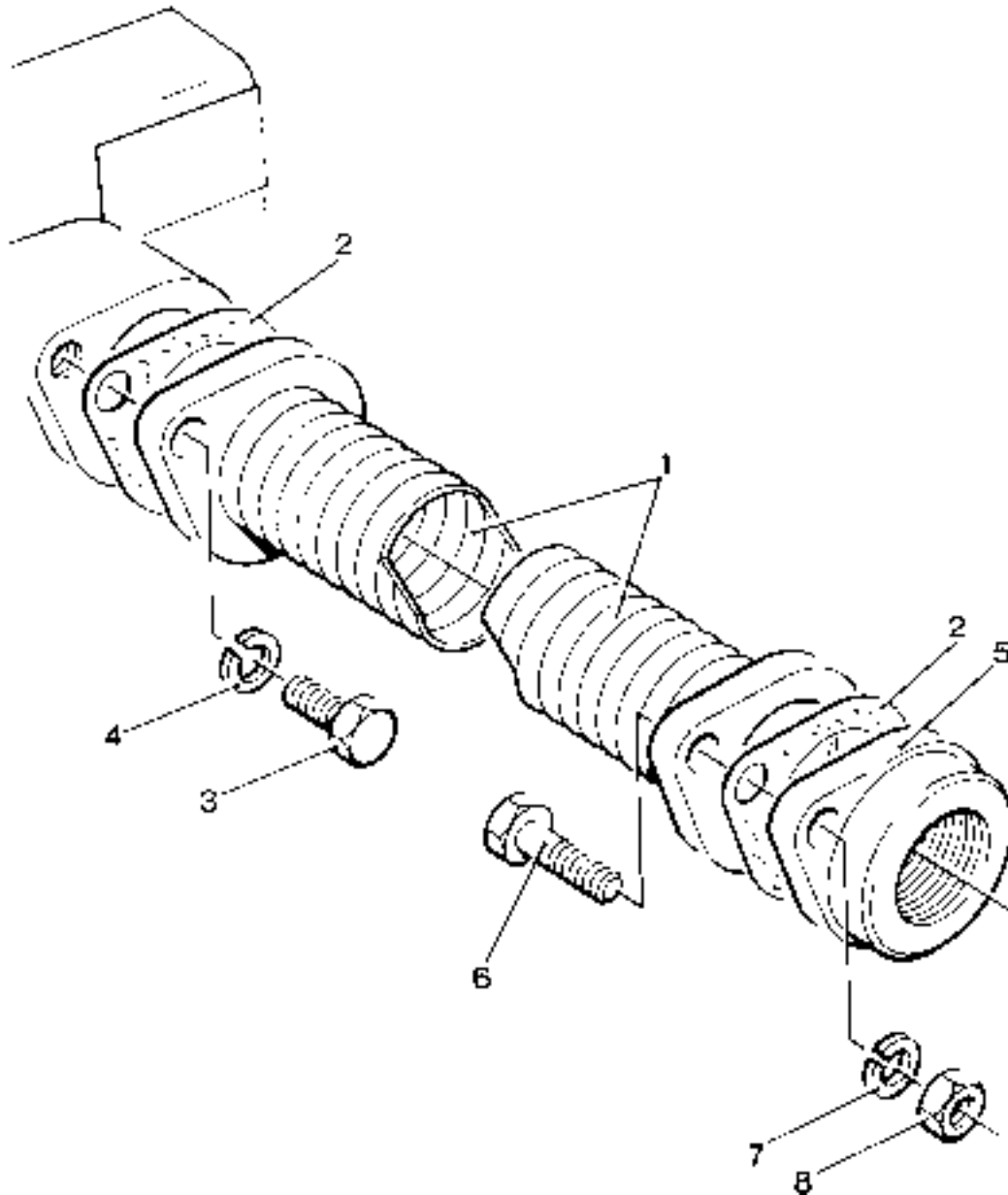

Starter Motor

Illustration T324
No. Description

TS/TR
Part Number 1 2 3 Remarks

	Accessory Kit Code EK	570-30421	1	1	1	12V pre-engaged. Includes code EM
	Accessory Kit Code EL	570-30431	1	1	1	24V pre-engaged. Includes code EM
1	Starter Motor - 12V Lucas	202-34963	1	1	1	
-	Starter Motor - 12V Bosch	202-42470	1	1	1	Replaced by 12V Lucas type
-	Starter Motor - 24V Bosch	202-44940	1	1	1	Replaces 202-44941
	Accessory Kit Code EM	570-31750	1	1	1	Spacer kit for Starter Motor with SAE1 flange. Comprises no's 2-7.
2	Spacer	202-33180	1	1	1	
3	Earth Terminal Stud	272-00605	1	1	1	
4	Stud	858-00108	2	2	2	
5	Spring Washer	272-00072	3	3	3	
6	Washer	027-00545	2	2	2	
7	Nut	272-00004	3	3	3	
8	Terminal Lug	064-15649/010	2	2	2	
9	Terminal Lug	064-15651/010	1	1	1	
10	Terminal Lug	064-15648/013	1	1	1	
11	Terminal Lug	064-15649/011	1	1	1	
12	Terminal Lug	064-15648/014	1	1	1	
13	Push-on Connector	064-33068/002	1	1	1	
14	Cover	064-33991/002	1	1	1	

Illustration T324

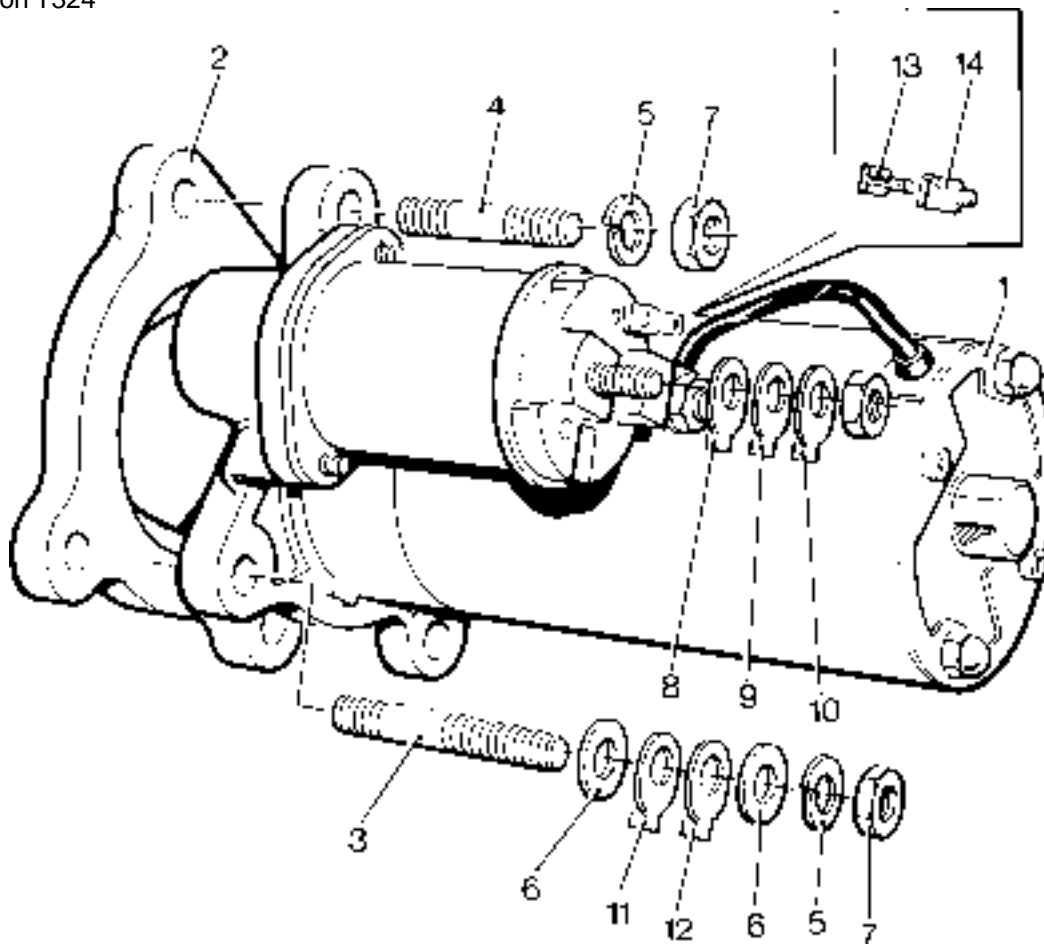

24V Co-axial Starter

Illustration T346
No. Description

TS/TR

Part Number 1 2 3 Remarks

No.	Description	Part Number	1	2	3	Remarks
	Accessory Kit Code EN	570-31760	1	1	1	Spacer kit. Comprises no's 2-5.
1	Starter Motor	366-07703	1	1	1	
2	Spacer	202-33160	1	1	1	
3	Stud - M10 x 65mm	272-00171	3	3	3	
4	Spring Washer	272-00072	3	3	3	
5	Nut.....	272-00004	3	3	3	
6	Terminal Lug	064-15648/010	1	1	1	
7	Terminal Lug	064-15649/007	1	1	1	
8	Terminal Lug	064-15651/010	1	1	1	

Illustration T346

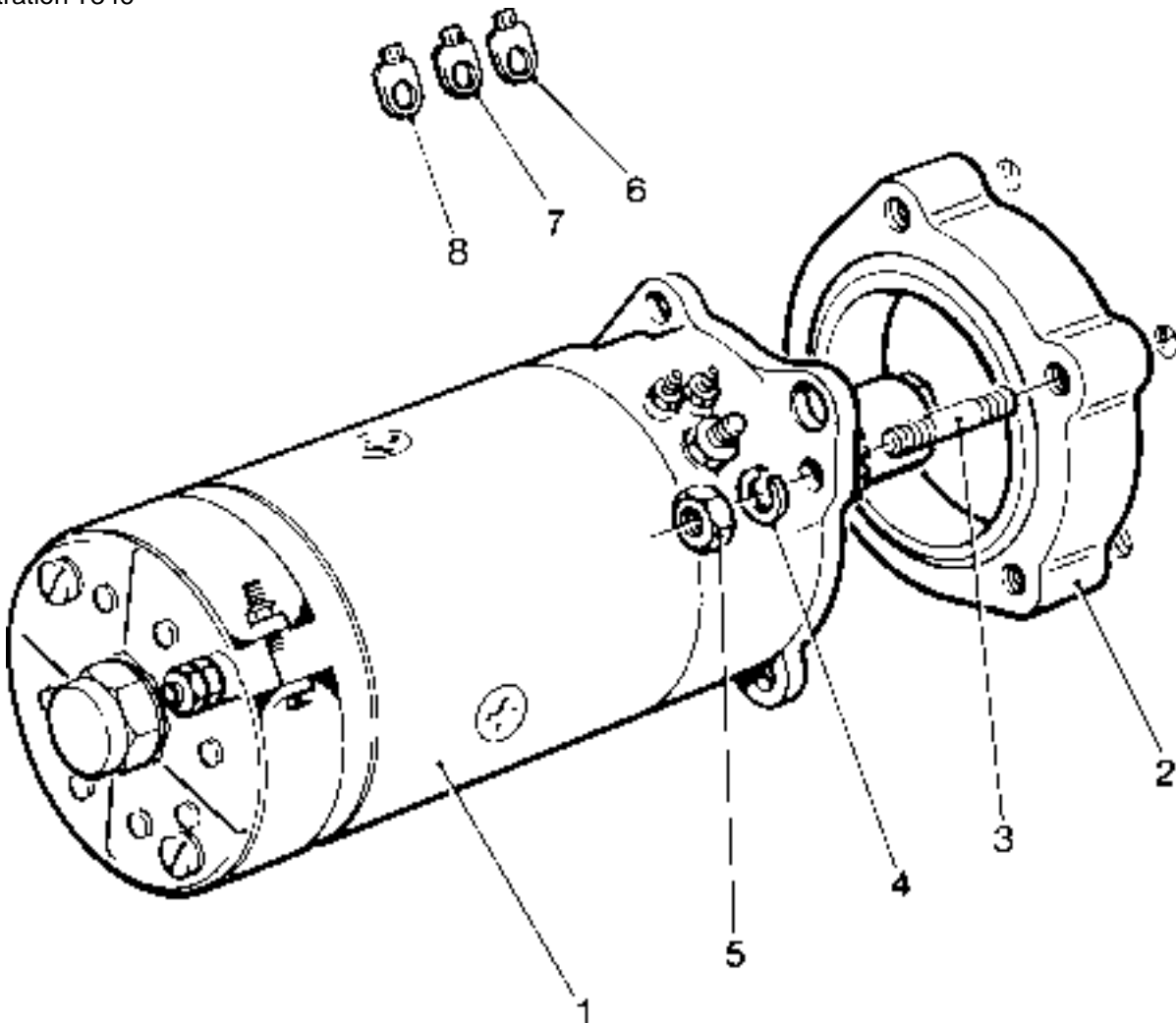

Starting Handle

Not Illustrated Description	Part Number	TS/TR			Remarks
		1	2	3	
Accessory Kit Code EA	601-53350	1	1	-	Gear end - short grip (standard)
Standard Handle - TS/TR1,2	601-52010	1	1	-	'Flush' type
Accessory Kit Code EB	570-31690	1	1	1	Gear end - long grip
Long Grip Handle	570-31000	1	1	1	'Flush' type
Accessory Kit Code ED	570-31710	1	1	1	Gear end hydraulics - assembled
Long Grip Handle	570-30112	1	1	1	
Accessory Kit Code EF	570-31730	1	1	1	Gear end hydraulics - kit form
Long Grip Handle	570-30451	1	1	1	
Starting Dog	201-31951	1	1	1	
Accessory Kit Code MEG	570-60340	-	1	1	Marine Starting Handle
Starting Handle Assembly	854-00526	-	1	1	For use with code MER

Limited Kickback Starting Handle - Gear End

Illustration T420 No.	Description	Part Number	TS/TR			Remarks
			1	2	3	
	Accessory Kit Code ER	570-35724	1	1	1	Replaces 570-35721
1	Starting Dog Assembly	201-47660	1	1	1	
2	Bissel Pin	601-43750	1	1	1	
3	End Cover Joint	201-33011	1	1	1	
4	End Cover Assembly	201-47990	1	1	1	Replaces 201-33853
5	Bearing Housing Assembly	201-47711	1	1	1	Replaces 201-47710. See Note
6	Bolt	272-00657	4	4	4	Replaces 272-00243
7	Washer	272-00688	4	4	4	
8	Starting Handle Assembly	201-47692	1	1	1	Replaces 201-47690

Note:

Bearing Housing Assemblies 201-47711 and 201-47710 are not interchangeable.

Limited Kickback Starting Handle - Gear End Hydraulics

Illustration T419 No.	Description	Part Number	TS/TR			Remarks
			1	2	3	
	Accessory Kit Code EX	570-35725	1	1	1	Replaces 570-35722
1	Starting Dog Assembly	201-47660	1	1	1	
2	Bissel Pin	601-43750	1	1	1	
3	End Cover Joint	201-33011	1	1	1	
4	End Cover Assembly	201-47993	1	1	1	Replaces 570-31071
5	Bearing Housing Assembly	201-47711	1	1	1	Replaces 201-47710. See Note
6	Bolt	272-00657	4	4	4	Replaces 272-00243
7	Washer	272-00688	4	4	4	
8	Starting Handle Assembly	201-47701	1	1	1	Replaces 201-47700

Note:

Bearing Housing Assemblies 201-47711 and 201-47710 are not interchangeable.

Illustration T420

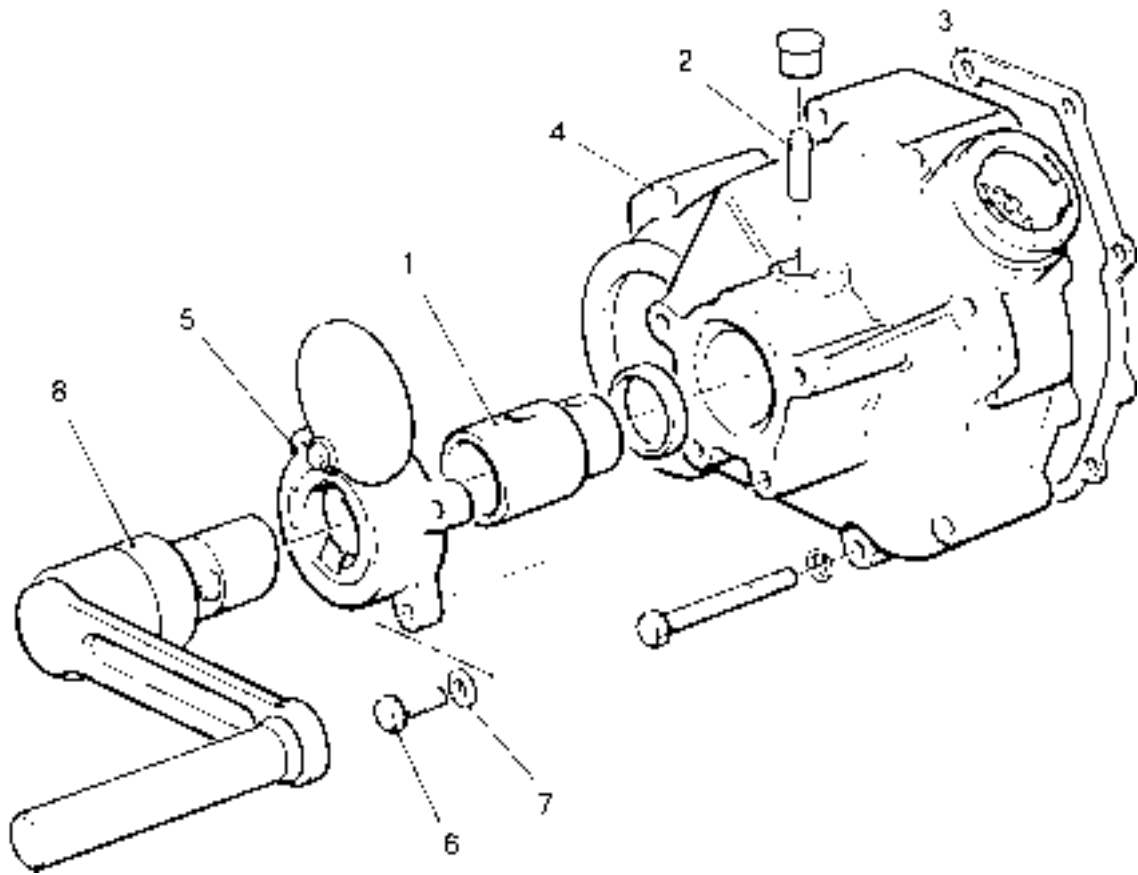
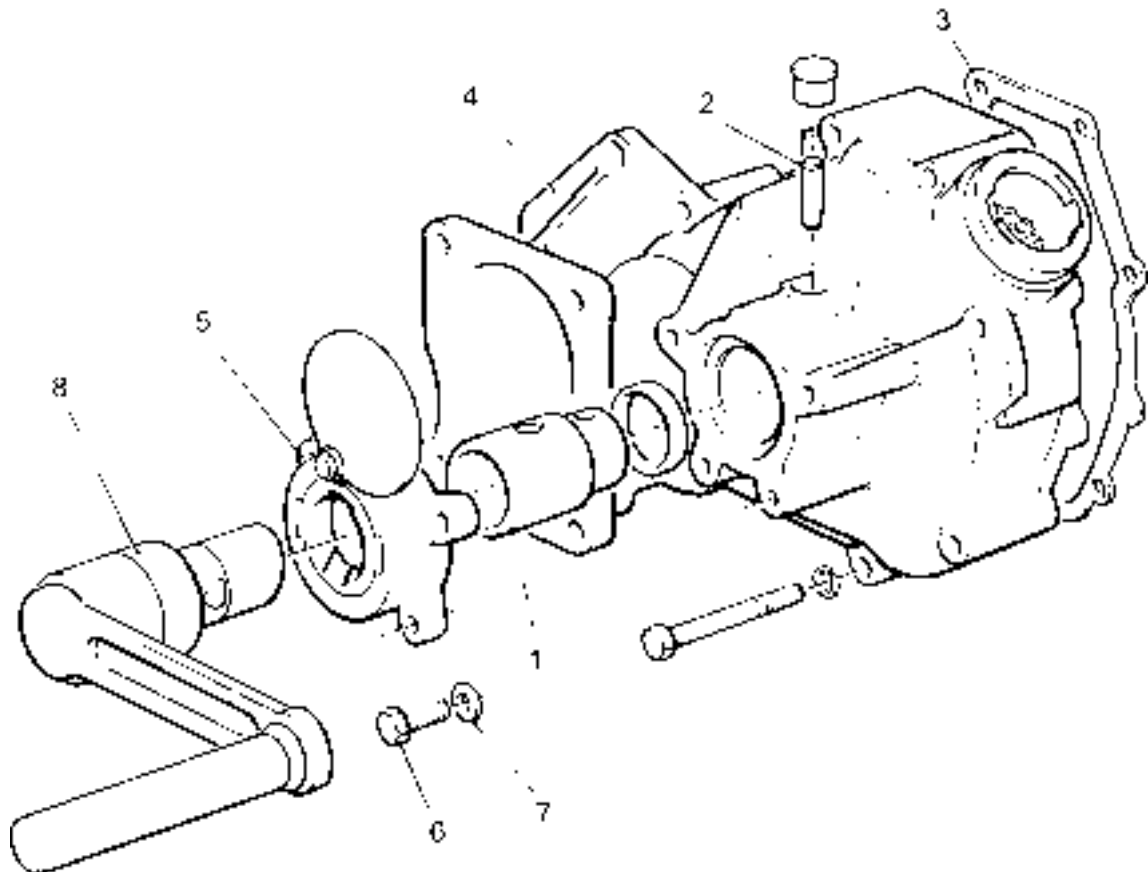

Illustration T419



Alternator - TS/TR2, 3 - Build 05

Illustration T138 No.	Description	Part Number	TS/TR			Remarks
			1	2	3	
1	Alternator - Lucas	382-08919	-	1	1	
2	Mounting Bracket	366-07048	-	1	1	
3	Setscrew - M8 x 25mm	272-00040	-	4	4	
4	Copper Washer	616-01608	-	4	4	
5	Spacer	366-07054	-	1	1	
6	Bolt - M8 x 130mm	272-00352	-	1	1	
7	Washer	027-00184	-	1	1	
8	Spring Washer	272-00071	-	1	1	
9	Nut	272-00003	-	1	1	
10	Alternator Pulley	366-07686	-	1	1	
11	Belt	601-37010	-	1	1	
12	Stud - 7/16" UNF/UNC x 5 1/2"	270-00398	-	1	1	
13	Spacer	366-07179	-	1	1	
14	Adjusting Link	366-07045	-	1	1	
15	Spring Washer	027-00985	-	1	1	
16	Nut	270-00005	-	1	1	
17	Spacer	366-07051	-	1	1	
18	Bolt M8 x 60mm	272-00045	-	1	1	
19	Washer	027-00184	-	1	1	
20	Washer	027-00545	-	1	1	
21	Pulley - Crankshaft Drive	201-32961	-	1	1	
22	Setscrew	272-00040	-	4	4	
23	Springwasher	272-00071	-	4	4	
24	Dowel	291-22470	-	2	2	
25	Extension Shaft	201-32910	-	1	1	
26	Stud	363245	-	1	1	
27	Shim	201-32970	-	1	1	

Illustration T138

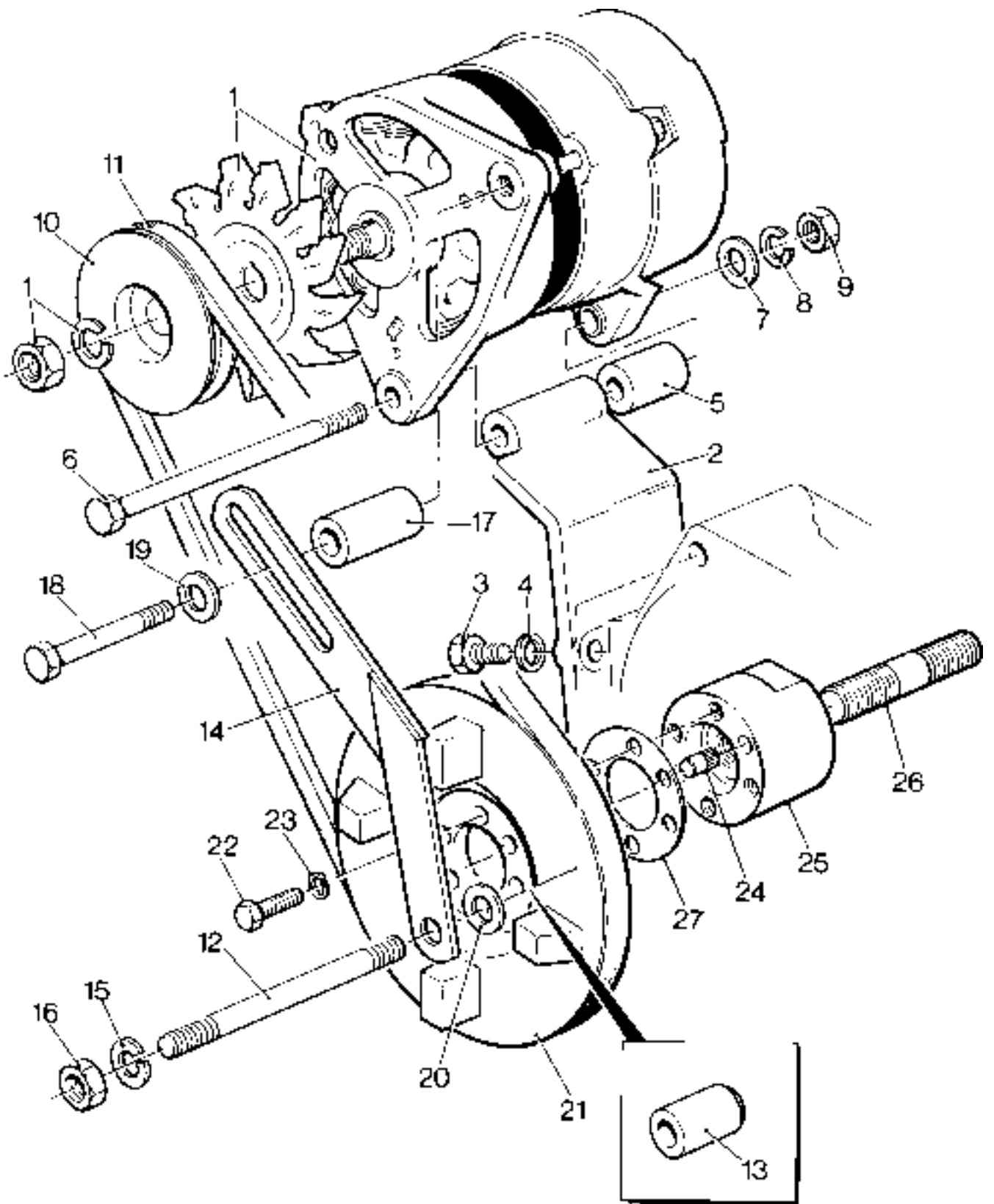

Alternator - TS2,3

Not Illustrated Description	Part Number	TS/TR			Remarks
		1	2	3	
Accessory Kit Code EP	570-35760	-	1	1	
Bracket	201-43973	-	1	1	
Setscrew	272-00039	-	6	6	
Spring Washer	272-00071	-	9	9	
Bracket Assembly	366-09062	-	1	1	
Nut	272-00003	-	2	2	
Alternator	366-08009	-	1	1	
Pulley	201-43782	-	1	1	
Bolt	272-00352	-	1	1	
Spacer	366-08241	-	1	1	
Adjusting Bracket	201-43984	-	1	1	
Setscrew	272-00040	-	4	4	
Plain Washer	272-00082	-	3	3	
Belt	751-17560	-	1	1	
Connector Plug	757-19520	-	1	1	
Washer	785632	-	1	1	
Washer	785642	-	2	2	

Variable Speed Control - Lever Operated Engine Mounted

Illustration T115
No. Description

TS/TR
1 2 3 Remarks

No.	Description	Part Number	1	2	3	Remarks
	Accessory Kit Code KB	570-31911	1	1	1	
1	Control Lever assembly	202-34222	1	1	1	
2	Connecting Plate	202-34210	1	1	1	
3	Anchor Plate	202-34181	1	1	1	
4	Spring Disc Washer	601-33110	1	1	1	
5	Hand Lever	601-33061	1	1	1	
6	Adjusting Screw	601-33120	1	1	1	
7	Copper Washer	366-07279	2	2	2	
8	Cheese Head Screw - M6 x 12mm	272-00120	1	1	1	
9	Washer	027-00618	1	1	1	

Illustration T115

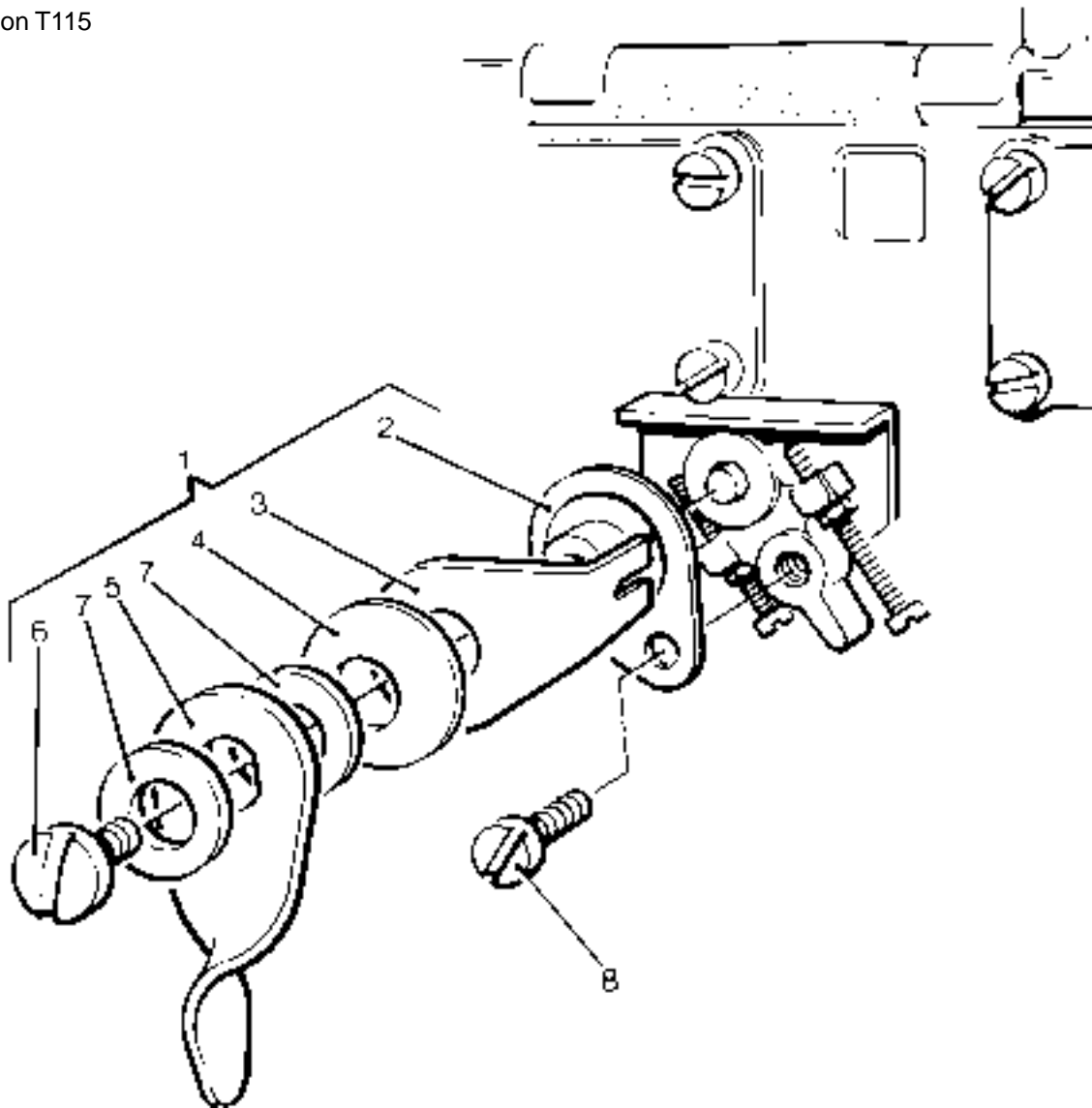

Variable Speed Control - Cable Operated

Illustration T423
No. Description

TS/TR
Part Number 1 2 3 Remarks

	Accessory Kit Code KA - TS/TR1	570-32870	1	-	-	
	Accessory Kit Code KA - TS/TR2,3	570-31901	-	1	1	
	Accessory Kit Code KC - TS/TR1	570-32900	1	-	-	Less cable and lever
	Accessory Kit Code KC - TS/TR2,3	570-31921	-	1	1	Less cable and lever
1	Lever	366-07068	1	1	1	
2	Cheese Head Screw - M6 x 12mm	272-00120	1	1	1	
3	Copper Washer	291-26090	1	1	1	
4	Mounting Bracket - TS/TR1	201-41070	1	-	-	
5	Setscrew - M6 x 20mm	272-00117	2	-	-	
6	Mounting Bracket - TS/TR2,3	366-07912	-	1	1	
7	Setscrew - M6 x 14mm	272-00034	-	2	2	
8	Spring Washer	272-00070	2	2	2	
9	Spring	601-33771	1	1	1	
10	Washer	027-00618	1	1	1	
11	Control Lever and Cable Assembly	366-07069	1	1	1	
12	Washer	366-06926	1	1	1	
13	Cable End Adjuster	366-07070	1	1	1	
14	Swivel Connector	366-07071	1	1	1	

Illustrator T423

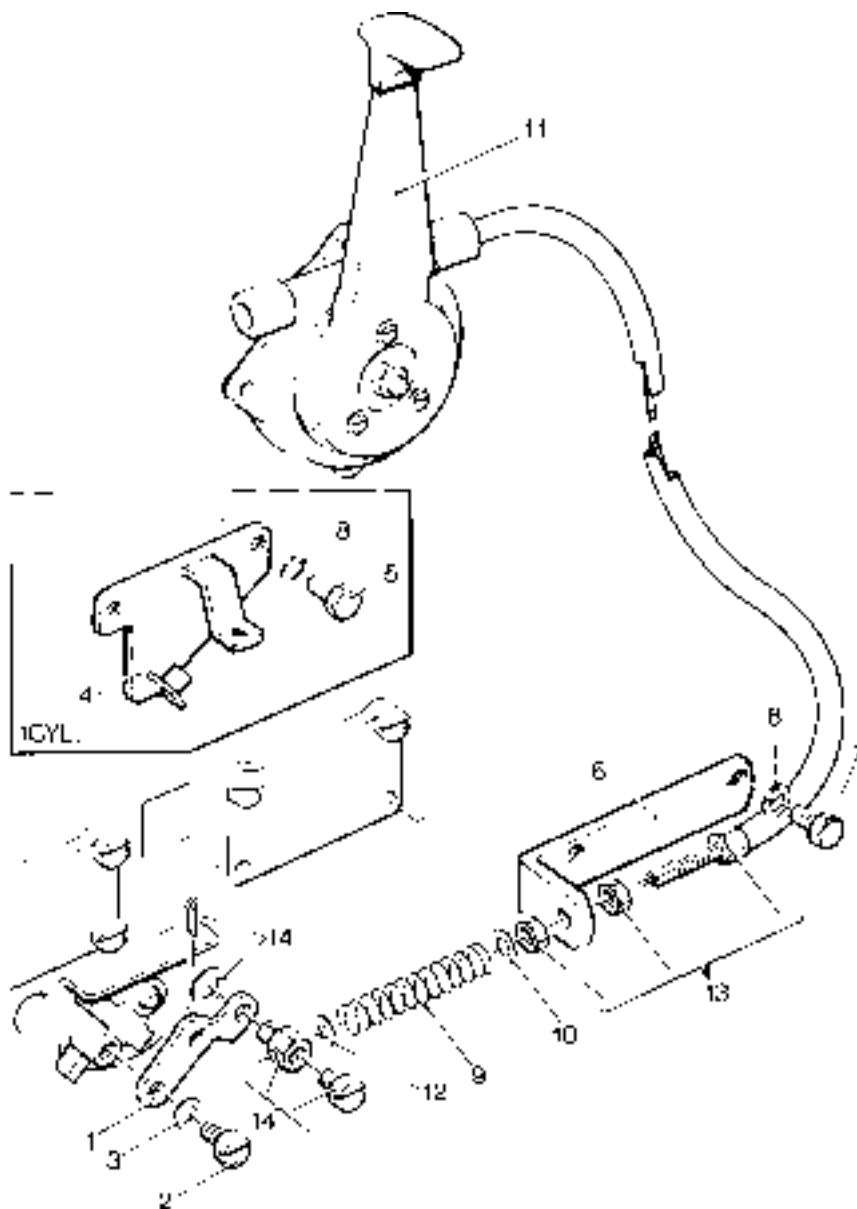

Two Speed Control - TS/TR1

Illustration T401
No. Description

TS/TR
Part Number 1 2 3 Remarks

No.	Description	Part Number	1	2	3	Remarks
	Accessory Kit Code KG	570-33200	1	-	-	
1	Spacer	601-41700	2	-	-	
2	Adjusting Link	201-41800	1	-	-	
3	Washer	272-00364	2	-	-	
4	Spring Washer	272-00070	2	-	-	
5	Bolt - M6 x 30mm	272-00035	2	-	-	
6	Spring	201-53140	1	-	-	
7	Bolt - M6 x 25mm	272-00256	1	-	-	
8	Spacer	601-41700	1	-	-	
9	Washer	272-00364	2	-	-	
10	Spring Washer	272-00070	1	-	-	
11	Nut	272-00002	1	-	-	
12	Speed Control Lever	366-08282	1	-	-	Replaces 201-41791
13	Spring Washer	272-00070	1	-	-	
14	Setscrew - M6 x 12mm	272-00032	1	-	-	
15	Washer	064-06612/006	2	-	-	

Illustration T401

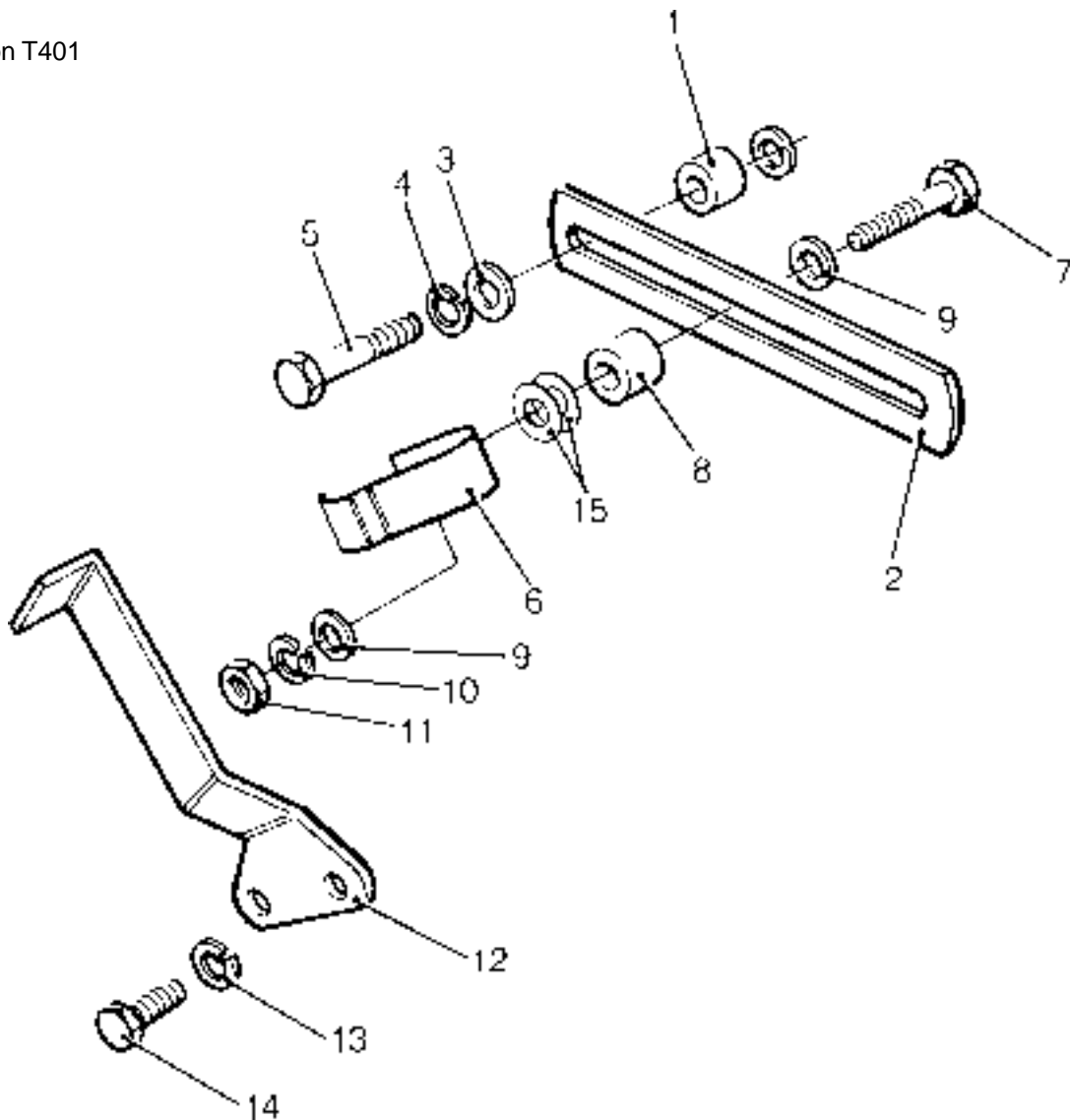

Two Speed Control - TS/TR2,3

Illustration T402
No. Description

No.	Description	Part Number	TS/TR			Remarks
			1	2	3	
	Accessory Kit Code KG	570-33460	-	1	1	
1	Spacer	601-41700	-	2	2	
2	Spring Carrier Plate	201-42990	-	1	1	
3	Spring Washer	272-00070	-	4	4	
4	Bolt - M6 x 25mm	272-00256	-	2	2	
5	Spring	201-53140	-	1	1	
6	Setscrew - M6 x 12mm	272-00032	-	2	2	
7	Washer	027-00618	-	1	1	
8	Nut	272-00002	-	1	1	
9	Speed Control Lever	366-08252	-	1	1	Replaces 366-07167
10	Washer	064-06612/006	-	3	3	

Illustration T402

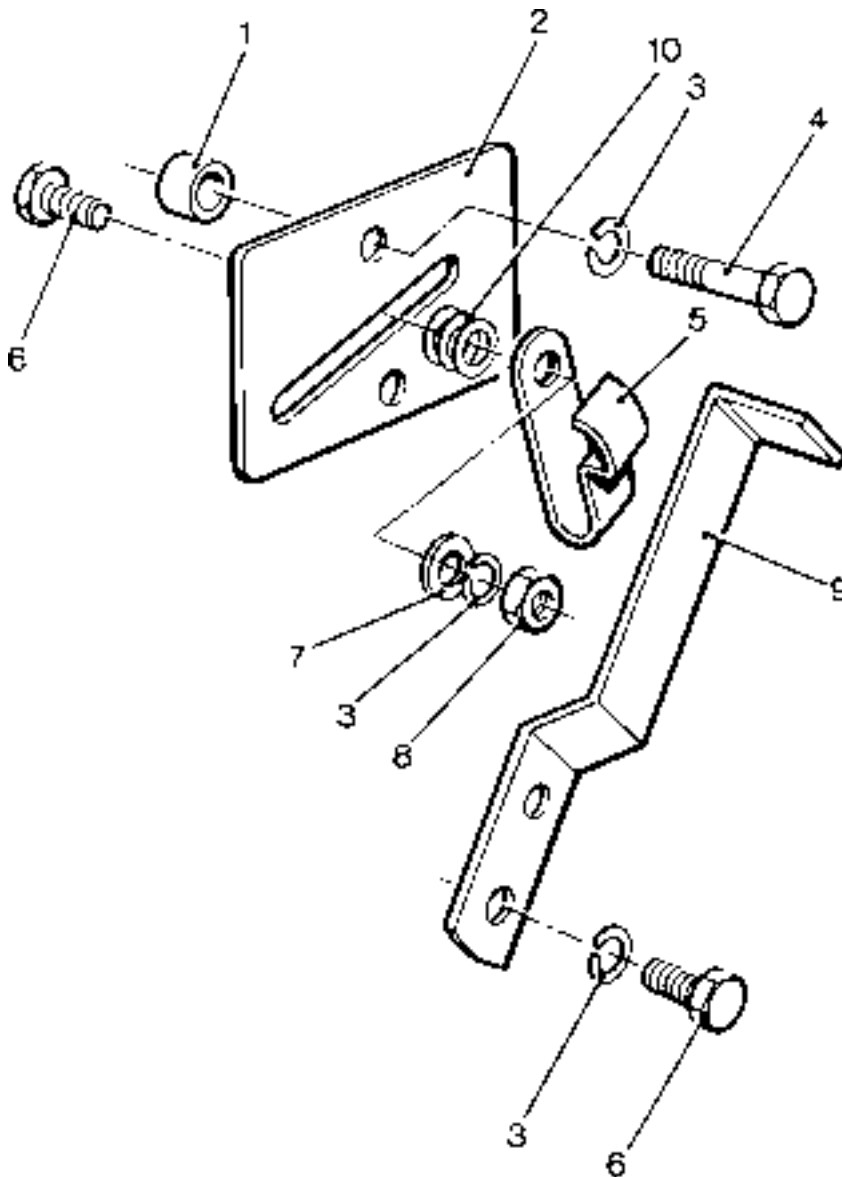

Two Speed Solenoid

Illustration T233

No.	Description	Part Number	TS/TR			Remarks
			1	2	3	
1	Solenoid	366-07216	-	1	1	
2	Connector	201-42630	-	1	1	
3	Nut - 1/4" UNF	270-00002	-	1	1	
4	Setscrew - M6 x 16mm	272-00034	-	4	4	
5	Spring Washer	272-00070	-	4	4	
6	Nut - M6	272-00002	-	4	4	
7	Setscrew - M8 x 30mm	272-00041	-	3	3	
8	Spring Washer	272-00071	-	3	3	
9	Mounting Bracket	366-07214	-	1	1	
10	Link	366-07215	-	1	1	
11	Split Pin	027-01986	-	4	4	
12	Washer	064-06612/004	-	4	4	
13	Speed Control Lever	366-06946	-	1	1	
14	Cheese Head Screw - M6 x 12mm	272-00120	-	1	1	
15	Spring Washer	064-02582/003	-	1	1	
16	Terminal	064-15649/012	-	2	2	

Illustration T233

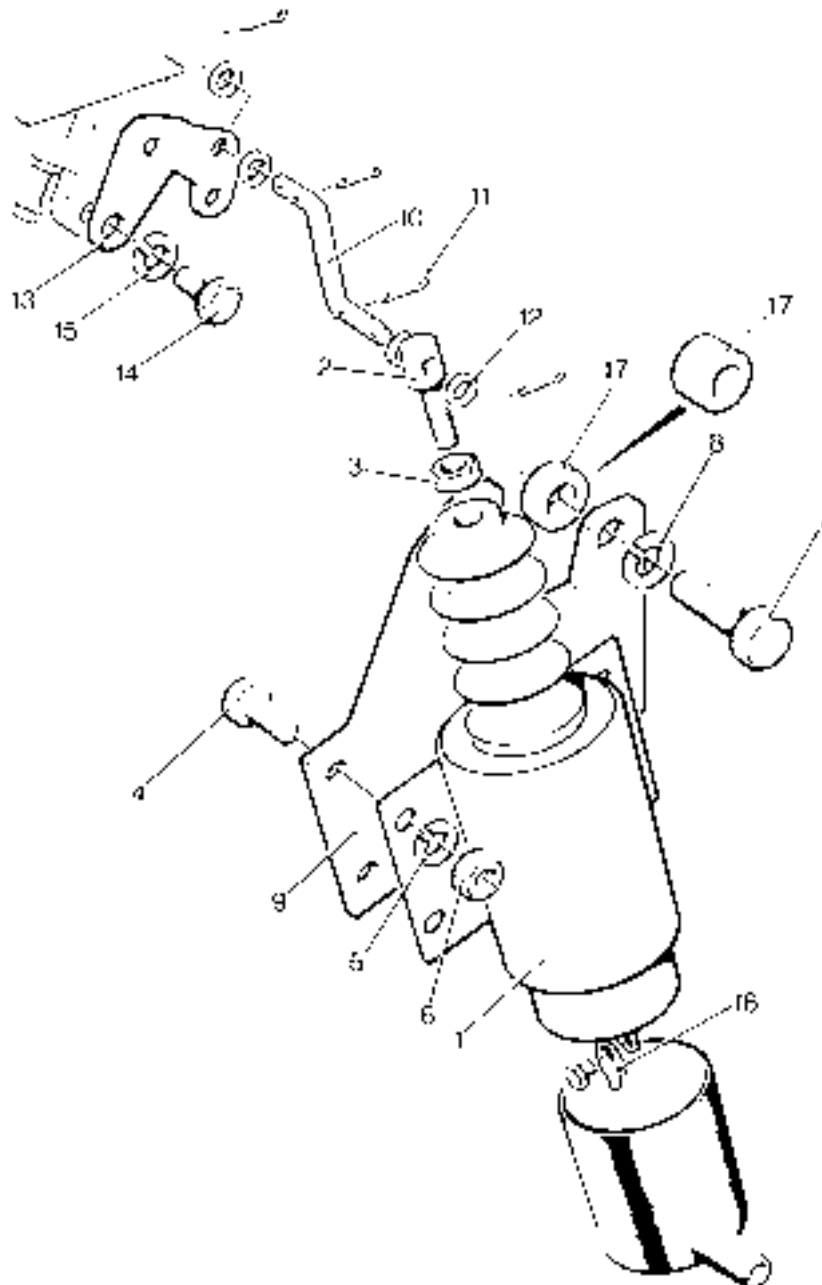

1,8 Metre Cable Operated Remote Stop

Illustration T111
No. Description

Part Number TS/TR
1 2 3 Remarks

Accessory Kit Code KD - TS/TR1	570-33180	1	-	-	
Accessory Kit Code KD - TS/TR2,3	570-31930	-	1	1	
- Cable Mounting Bracket - TS/TR1	201-41070	1	-	-	
- Setscrew - M6 x 20mm	272-00117	2	-	-	
1 Cable Mounting Bracket - TS/TR2,3	202-35990	-	1	1	
2 Setscrew - M6 x 16mm	272-00034	-	2	2	
3 Spring Washer	272-00070	2	2	2	
4 Cable	202-36050	1	1	1	
5 Return Spring	382-07369	1	1	1	
6 Locating Washer	366-06926	1	1	1	
- Stopping Lever - TS/TR1	201-41140	1	-	-	
7 Stopping Lever - TS/TR2,3	202-36030	-	1	1	
8 Cheese Head Screw - M5 x 12mm	272-00062	2	2	2	
9 Spring Washer	272-00069	2	2	2	
10 Washer	027-01698	2	2	2	
- Swivel Connector - TS/TR1	201-41130	1	-	-	
11 Swivel Connector - TS/TR2,3	366-07071	-	1	1	

Illustration T111

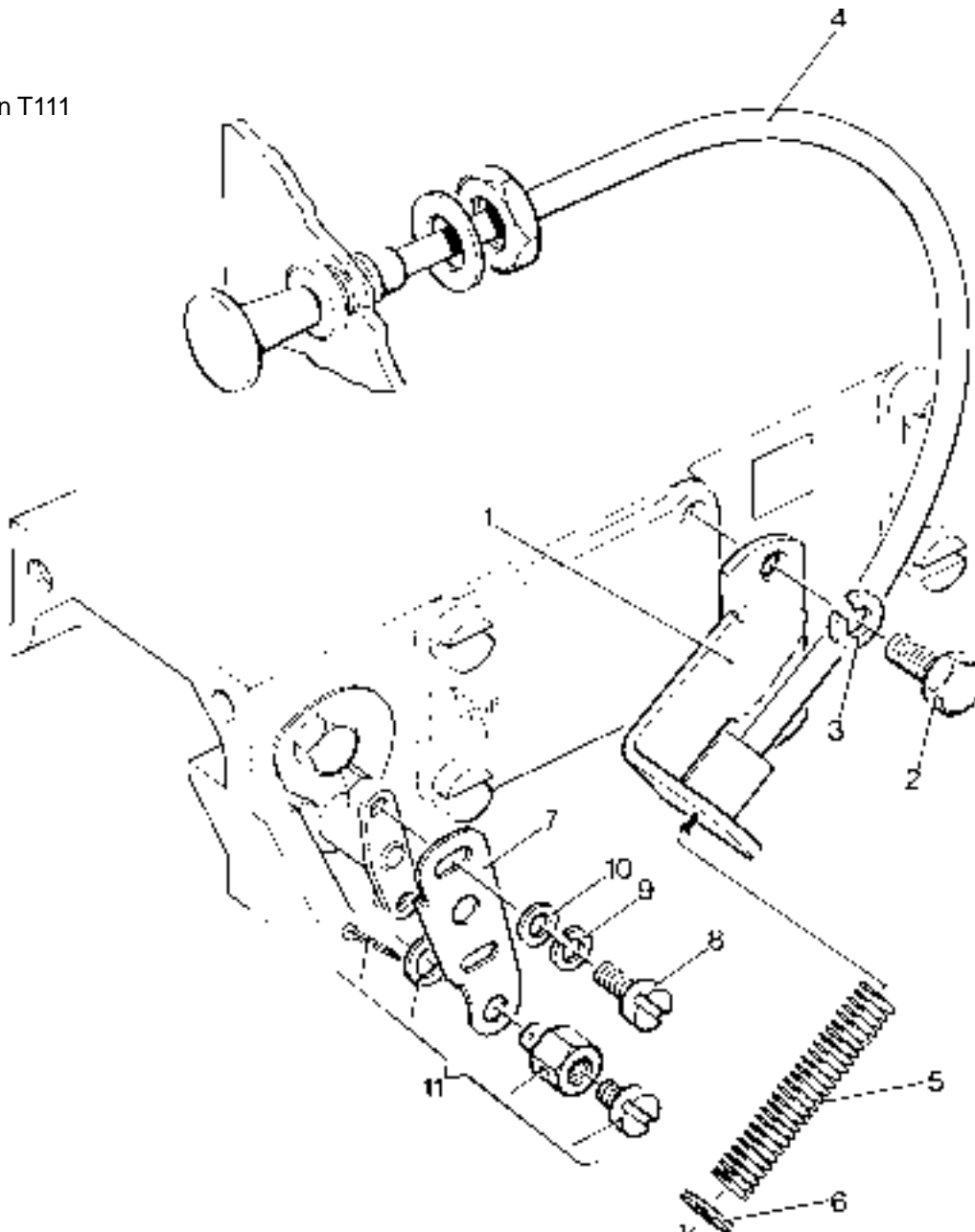

Dumper Accessories (Loose)

Illustration T425
No. Description

No.	Description	Part Number	TS/TR			Remarks
			1	2	3	
	Accessory Kit Code XD	570-41310	1	1	1	
1	Locknut	707004	1	1	1	
2	Washer	785352	1	1	1	
3	Bolt - M6 x 60mm	705231	1	1	1	
4	Eye Bolt	362612	1	1	1	
5	Speeder Spring	314554	1	1	1	
6	Pipe Connection	365253	1	1	1	
-	Dumper Hook-up Bracket Kit	570-34940	1	1	1	Not part of kit
7	Speed Control Lever	366-07888	1	1	1	Not part of kit
8	Screw - M6 x 12mm	272-00120	1	1	1	Not part of kit
-	Spring Washer	272-00070	1	1	1	Not part of kit

Illustration T425

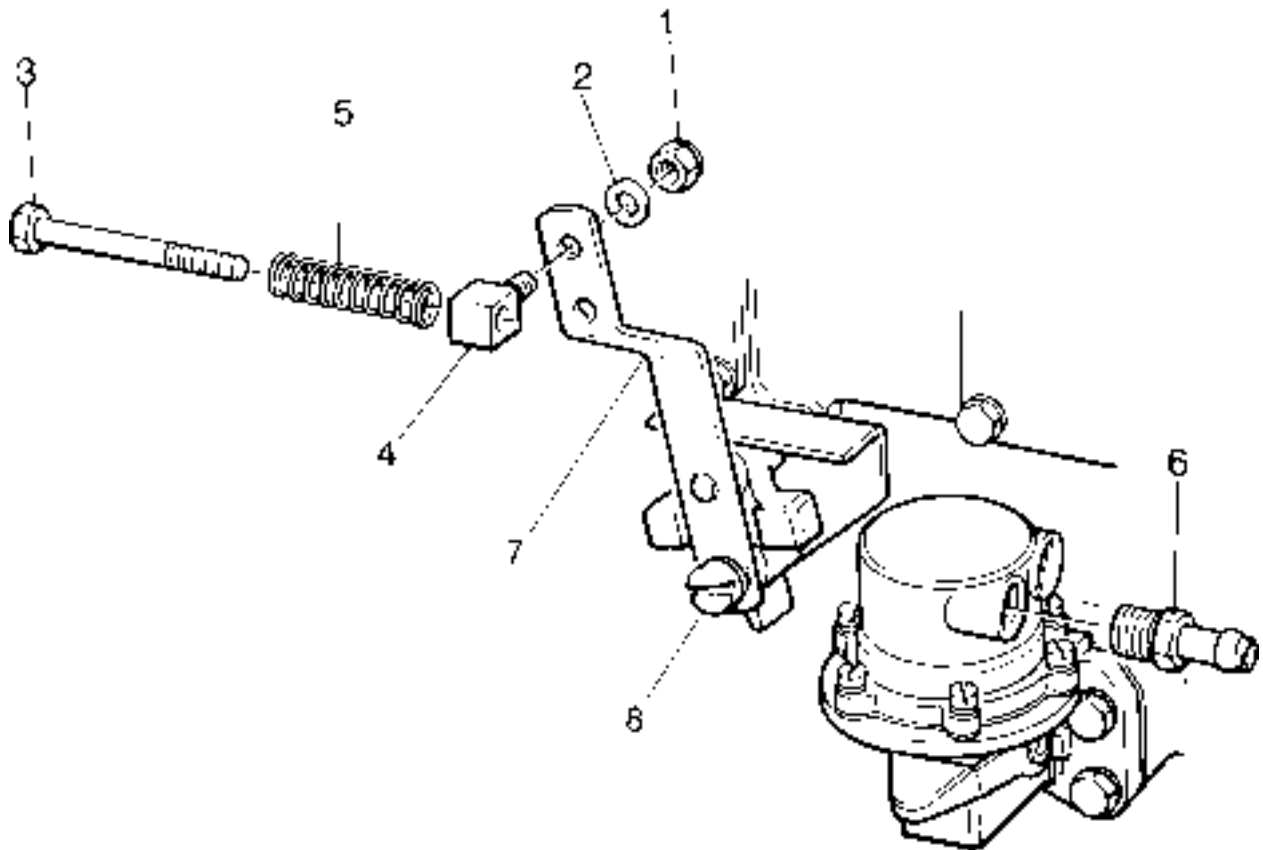

Electronic Governor Adaptor

Illustration T151

No.	Description	Part Number	TS/TR			Remarks
			1	2	3	
	Accessory Kit Code KE	570-33080	-	1	1	
1	Control Lever	570-33100	-	1	1	
2	Stopping Control Lever	201-31780	-	1	1	
3	Nut	272-00002	-	1	1	
4	Spring Washer	272-00070	-	1	1	
5	Spring	601-32670	-	1	1	
6	'O' Ring	201-13120	-	1	1	
7	End Cover Joint	201-33010	-	1	1	
8	Door Joint	201-30610	-	1	1	

Illustration T151

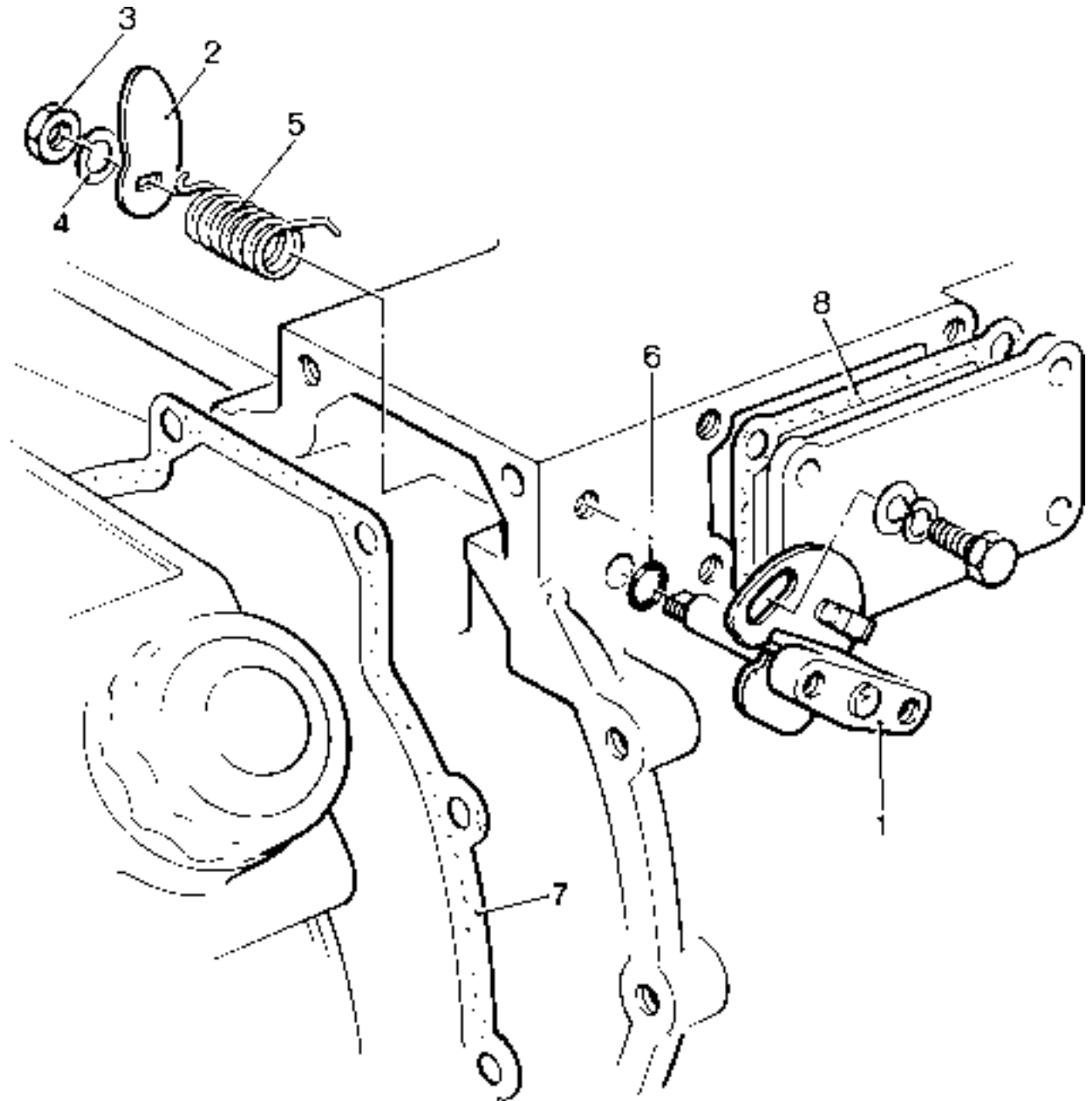

Shaft Extension - Flywheel End

Illustration T171
No. Description

TS/TR

No.	Description	Part Number	1	2	3	Remarks
	Accessory Kit Code BA	570-31460	1	1	1	40mm diameter. Comprises 2, 5 & 6
	Accessory Kit Code BB	602-51620	1	-	-	40mm diameter. Comprises 1, 4 & 6
	Accessory Kit Code BC	570-31470	1	1	1	Unmachined. Comprises 3, 5 & 6
1	Short Shaft Extension - TS/TR1	602-38680	1	-	-	3 bolt fixing
2	Long Shaft Extension	202-35271	1	1	1	
3	Long Shaft Extension	202-35272	1	1	1	Unmachined
4	Bolt - M12 x 50mm	272-00254	3	6	6	
5	Bolt - M12 x 55mm	272-00177	-	6	6	
6	Spring Washer	272-00073	3	6	6	

Illustration T171

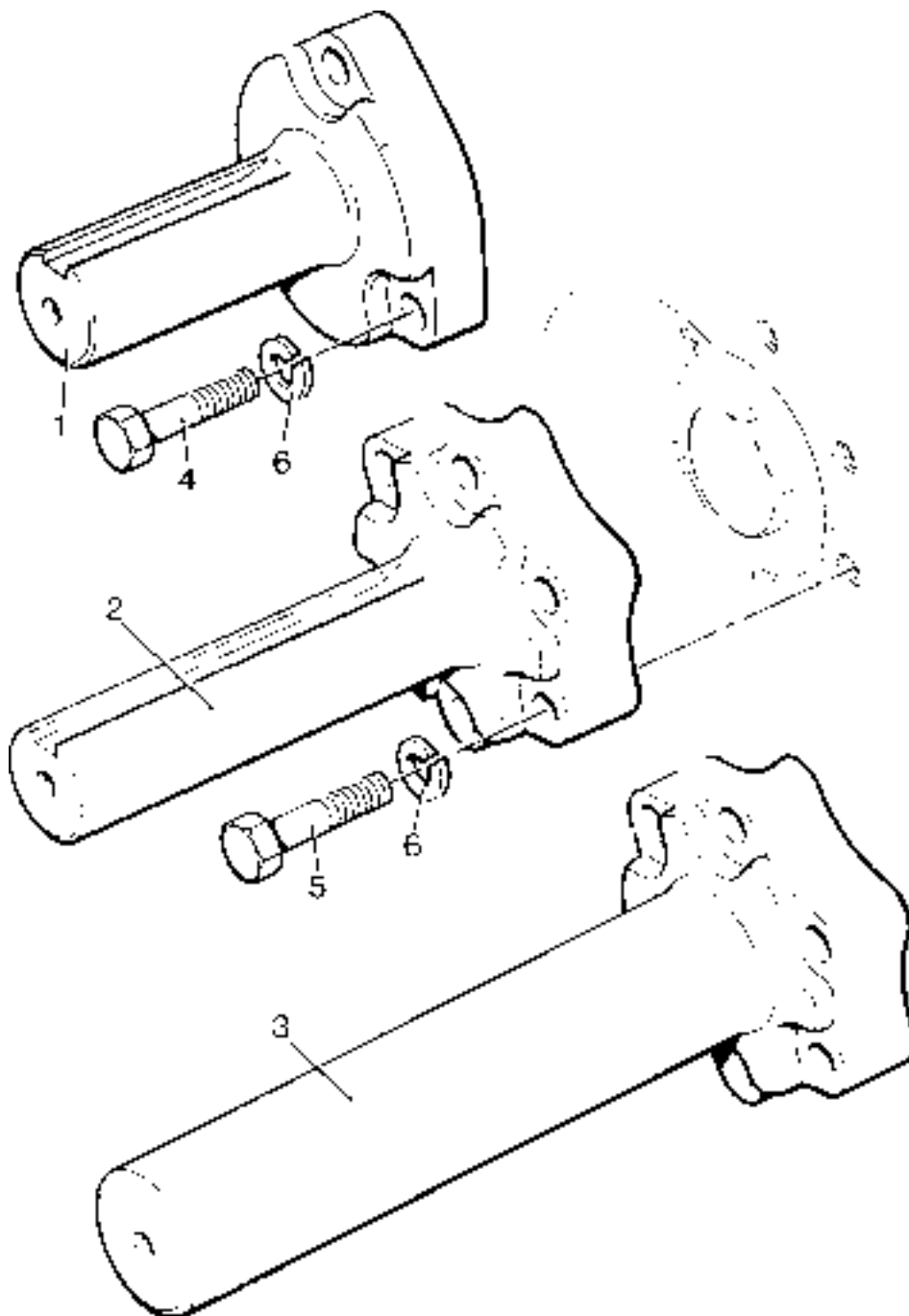

Shaft Extension - Gear End

Illustration T52
No. Description

Part Number TS/TR
1 2 3 Remarks

No.	Description	Part Number	TS	TR	Remarks
	Accessory Kit Code BW	570-31580	1	1	1 40mm diameter
1	End Cover	201-47981	1	1	1 Replaces 201-33850
2	Oil Seal	601-39550	1	1	1
3	Crankshaft Extension	202-35441	1	1	1
4	Stud	202-35430	1	1	1
5	Oil Seal	201-30690	1	1	1
6	End Cover Joint	201-33013	1	1	1

Illustration T52

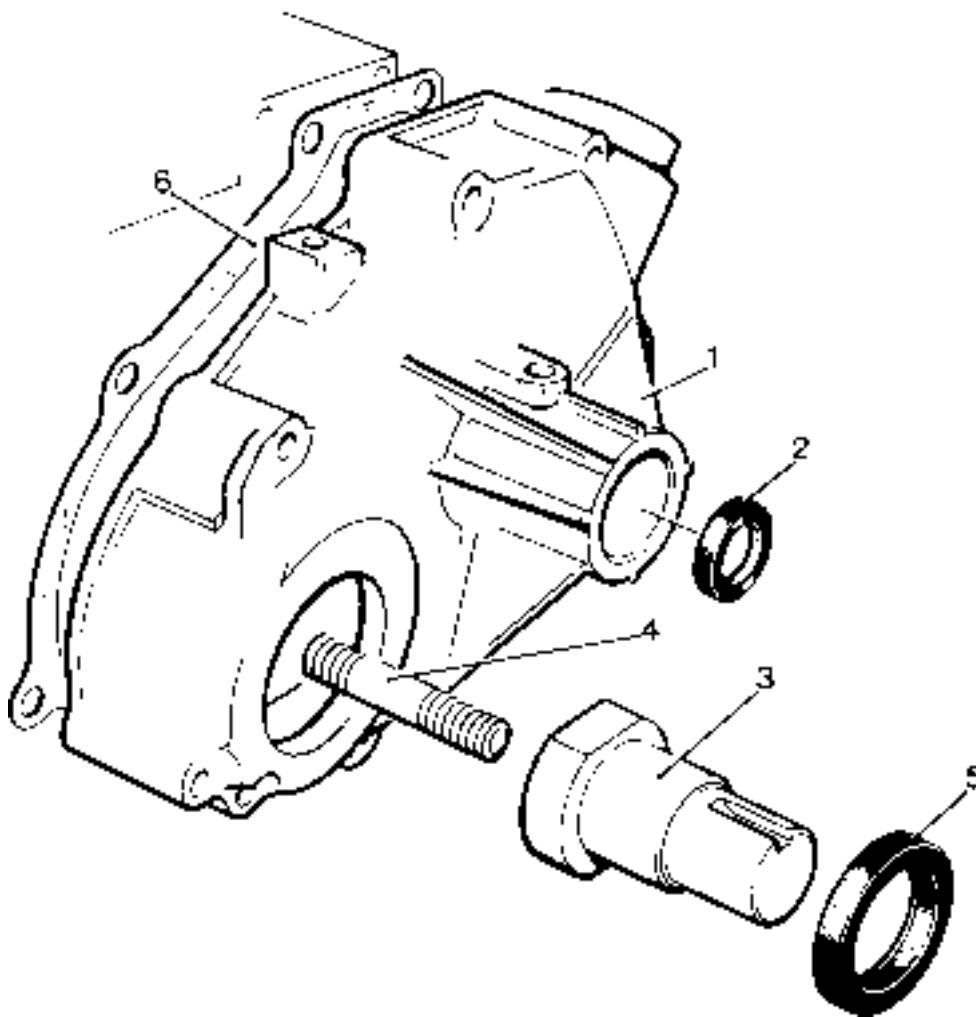

Shaft Extension Kit - TS/TR2,3

Illustration T145
No. Description

Part Number TS/TR
1 2 3 Remarks

	Accessory Kit Code XA	570-32880	1	1	1	
1	Extension Shaft	202-41310	1	1	1	
2	Bolt - M12 x 1.75-6g x 55mm	272-00177	6	6	6	
3	Spring Washer - M12	272-00073	6	6	6	

Illustration T145

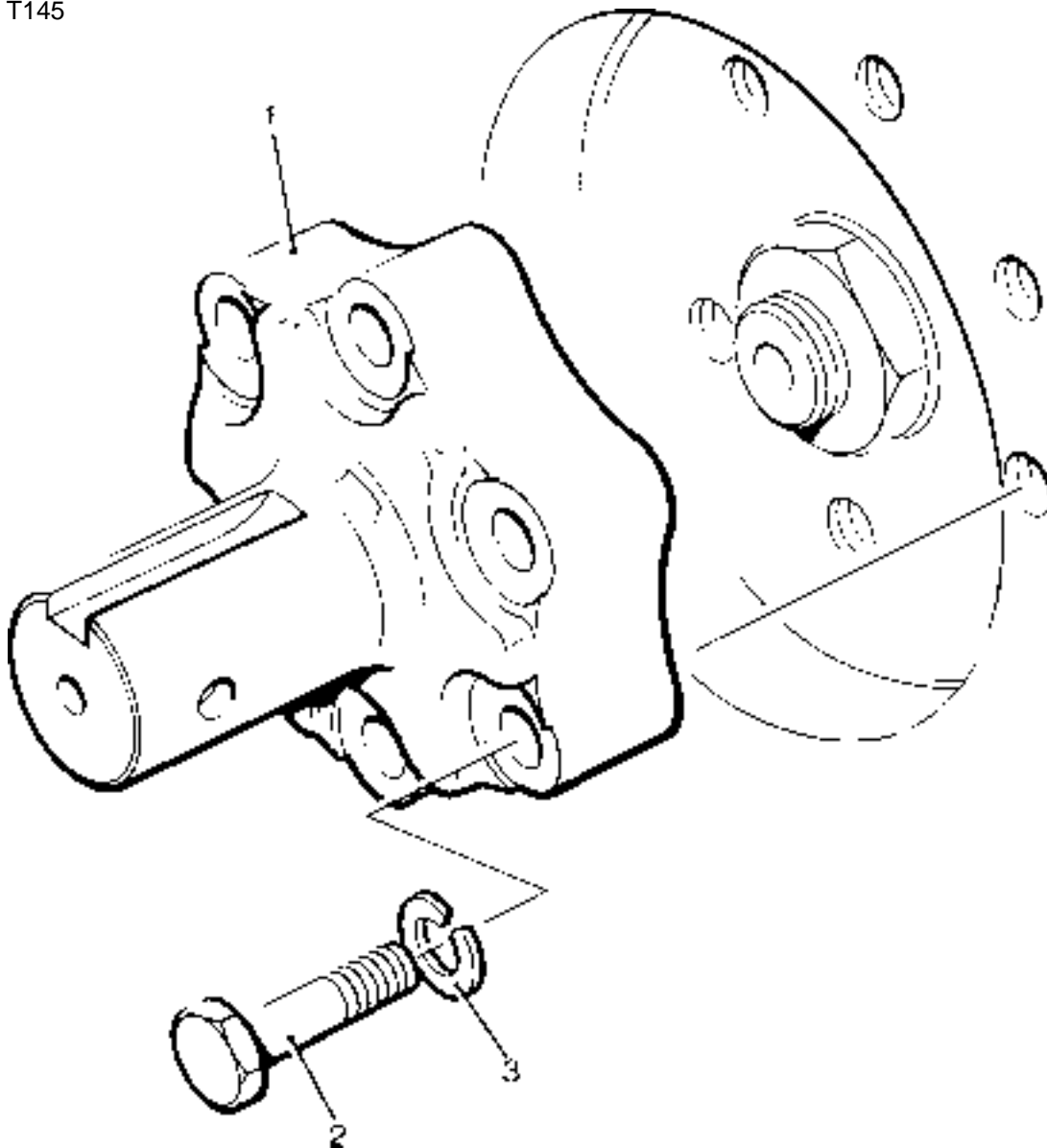

Shaft Extension - Gear End - Build 40

Illustration T146
No. Description

Part Number TS/TR
1 2 3 Remarks

No.	Description	Part Number	TS	TR	Remarks
1	Crankshaft Pinion	202-39890	1	1	1
2	Oil Seal	201-30690	1	1	1
3	Crankshaft Extension	202-39870	1	1	1
4	Driving Key	202-41250	2	2	2
5	Stud	202-39880	1	1	1
6	Nut.....	202-41690	1	1	1
7	Disc Spring Washer	639-11070	1	1	1

Illustration T146

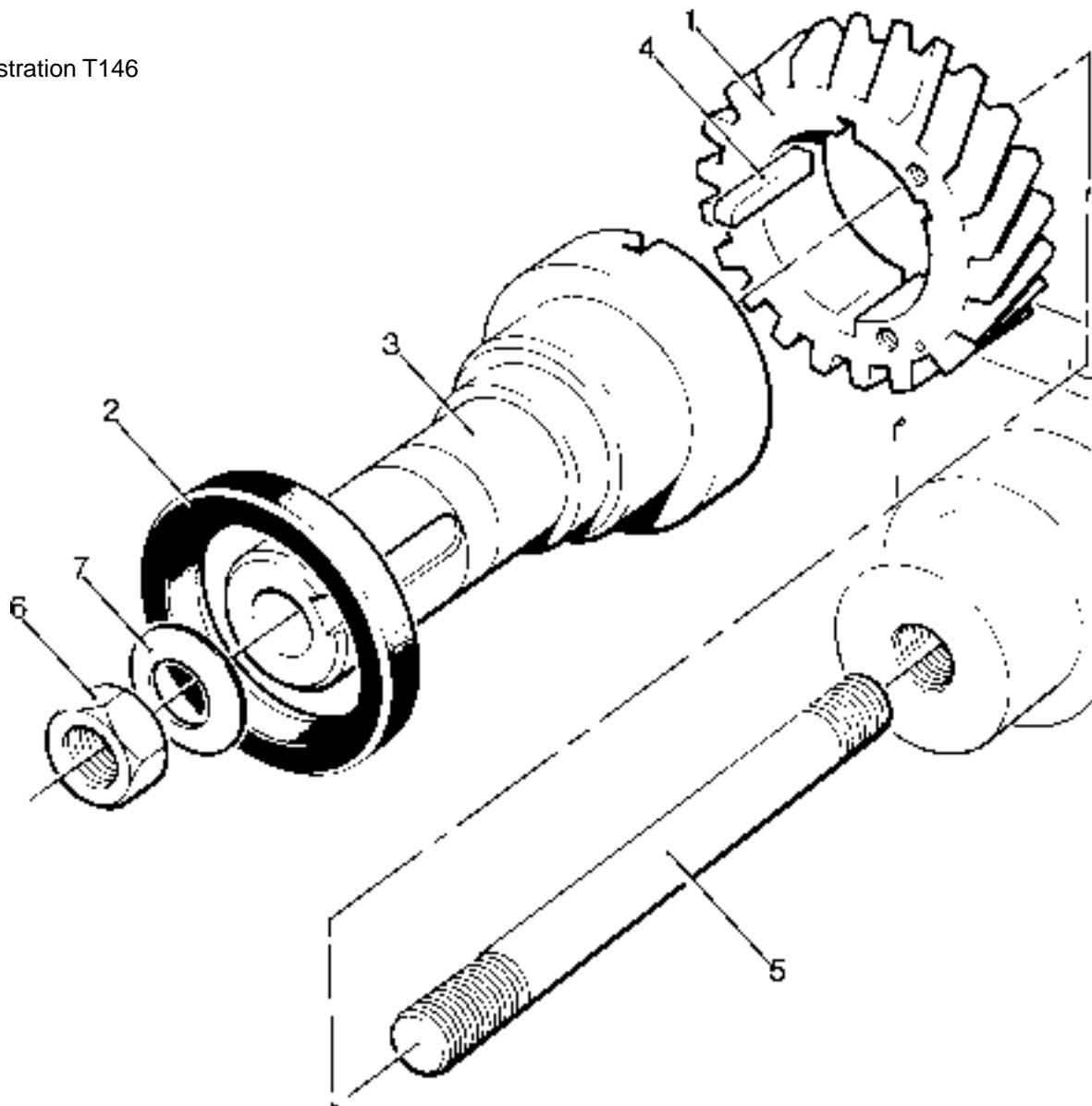

Oil Distribution Block - Flexible Pipes

Illustration T150
No. Description

TS/TR

No.	Description	Part Number	1	2	3	Remarks
	Accessory Kit Code LG	570-17100	1	1	1	
1	Swivel Union Plug	366-07039	1	1	1	
2	Copper Washer	616-01608	2	2	2	
-	Distribution Block Assembly	366-07157	1	1	1	
3	Plug	366-07041	1	1	1	
4	Plug	008-03019	1	1	1	
5	Union	291-21141	1	1	1	
6	Copper Washer	600-00106	2	2	2	
7	Distribution Block	366-07129	1	1	1	Replaces 366-07151
8	Flexible Pipe	366-07518	1	1	1	
9	Washer	027-00184	4	4	4	
10	Setscrew - M10 x 25mm	272-00067	2	2	2	

Illustration T150

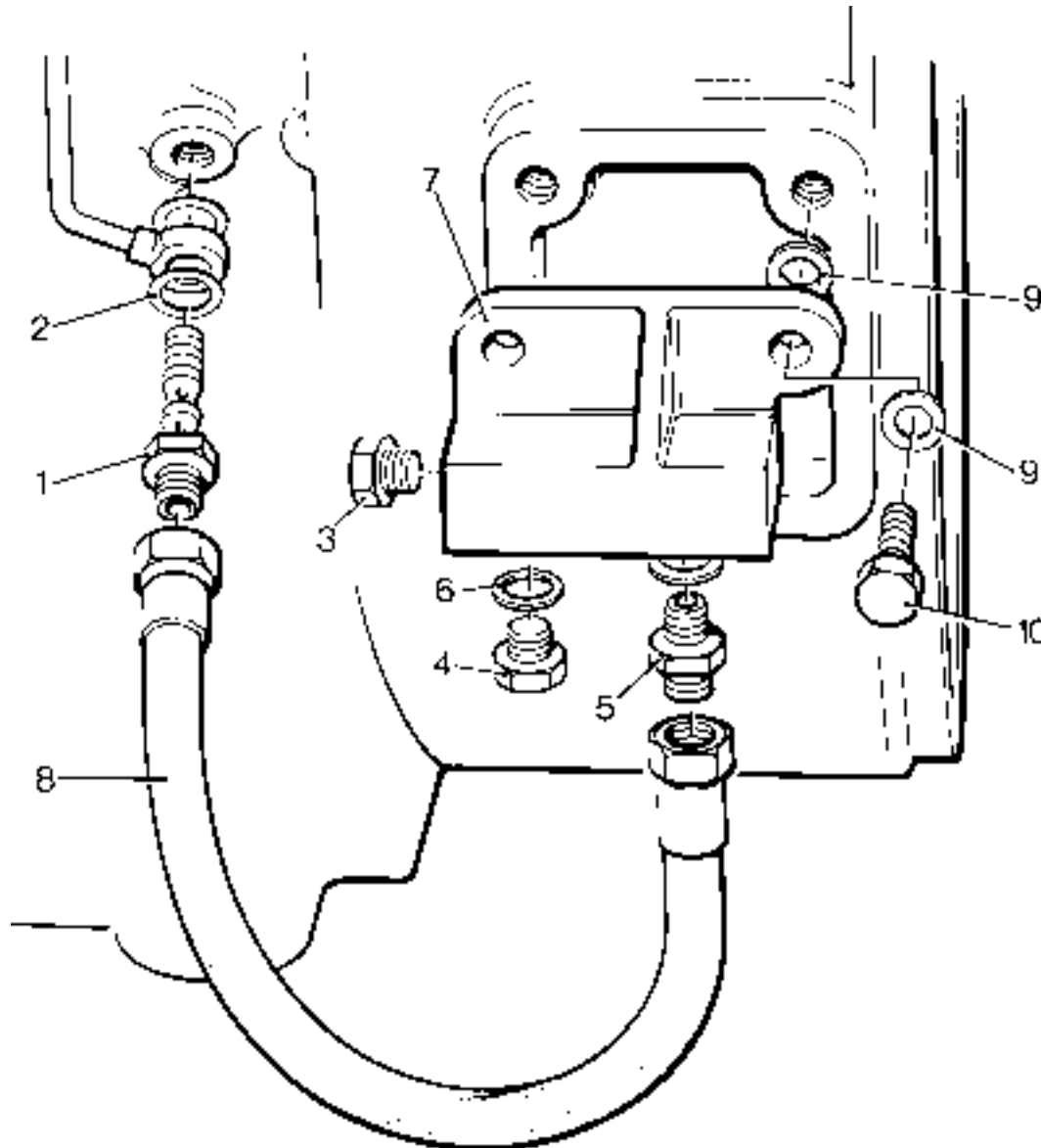

Oil Distribution Block - Steel Pipes - TS/TR2,3

Illustration T178
No. Description

TS/TR
Part Number 1 2 3 Remarks

No.	Description	Part Number	1	2	3	Remarks
	Accessory Kit Code LF	570-33090	-	1	1	
1	Swivel Union Plug	366-07039	-	1	1	
2	Copper Washer	616-01608	-	2	2	
3	Pipe Assembly	366-07112	-	1	1	
4	Oil Distribution Block Assembly	366-07114	-	1	1	
5	Plug	366-07041	-	1	1	
6	Plug	008-03019	-	1	1	
7	Union	291-21141	-	1	1	
8	Copper Washer	600-00106	-	2	2	
9	Oil Distribution Block	366-07129	-	1	1	Replaces 366-07151
10	Bracket Assembly	366-07110	-	1	1	
11	Bolt - M8 x 40mm	272-00043	-	1	1	
12	Setscrew - M10 x 25mm	272-00067	-	2	2	
13	Washer	272-00072	-	2	2	
14	Nut	272-00018	-	2	2	

Illustration T178

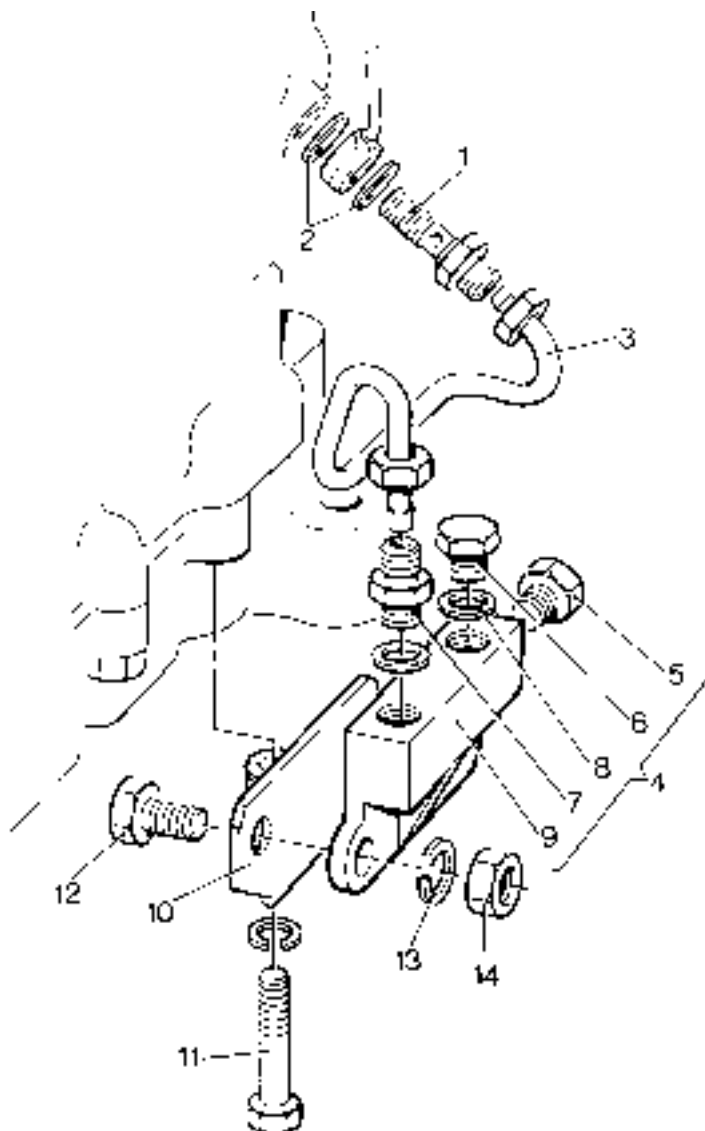

Oil Distribution Block - TR2

Illustration T431

No.	Description	Part Number	TS/TR			Remarks
			1	2	3	
	Accessory Kit Code JG	570-37360	-	1	-	
1	Spring Washer	272-00072	-	2	-	
2	Bolt - M10 x 40mm	272-00116	-	2	-	
3	Union	366-07038	-	1	-	
4	Swivel Union Plug	366-07039	-	1	-	
5	Plug	366-07041	-	1	-	
6	Flexible Pipe Assembly	366-07518	-	1	-	
7	Spacer	382-07208	-	2	-	
8	Copper Washer	616-01608	-	2	-	
9	Oil Distribution Block	757-12100	-	1	-	
10	Oil Pressure Switch	757-15420	-	1	-	

Illustration T431

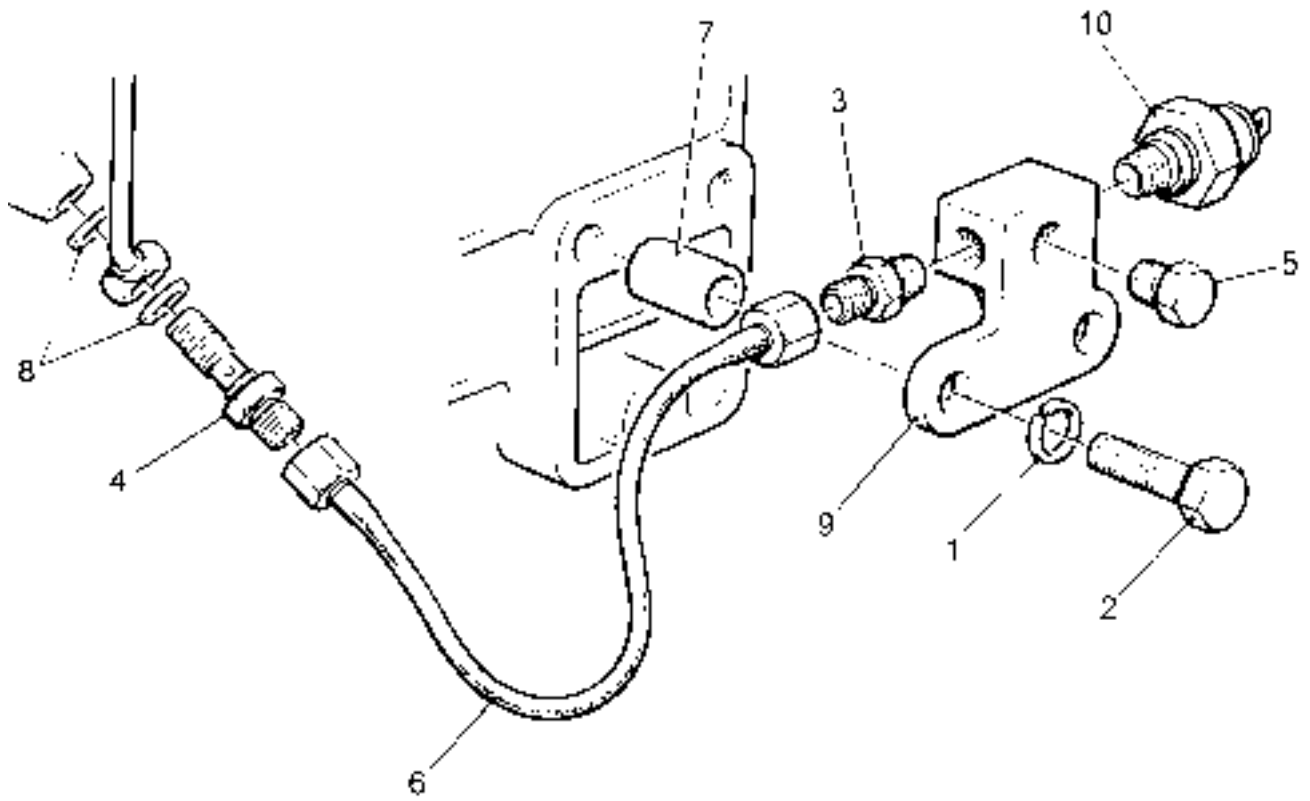

Temperature Switch

Illustration T80 No.	Description	Part Number	TS/TR			Remarks
			1	2	3	
	Accessory Kit Code JA	570-34200	1	1	1	Up to 1850 r/min, NC contacts
	Accessory Kit Code JB	570-32390	1	1	1	Above 1851 r/min, NC contacts
	Accessory Kit Code JM	570-36820	1	1	1	Up to 1850 r/min, NO contacts
	Accessory Kit Code JK	570-42170	1	1	1	NC contacts
1	Head Switch - up to 1850r/min	382-08564	1	1	1	Set at 150°C break on rise
-	Head Switch - above 1851r/min	202-36650	1	1	1	Set at 130°C break on rise
-	Head Switch	382-09120	1	1	1	Set at 150°C make on rise
-	Head Switch	366-07221	-	1	1	Set at 130°C make on rise
2	Push-on Connector	064-33068/001	2	2	2	
3	Cover	064-33991/001	2	2	2	
	Accessory Kit Code JC - TS/TR1	570-33220	1	1	1	Kit comprising no's 4, 5, 10, 11
	Accessory Kit Code JC - TS/TR2,3	570-30540	1	1	1	Kit comprising no's 4-11
4	Air Temperature Switch	202-45310	1	1	1	
5	Moulded Seal	202-37580	1	1	1	
6	Mounting Bracket	202-36670	1	1	1	
7	Clamp	382-08102	1	1	1	
8	Setscrew - M6 x 12mm	272-00032	2	2	2	
9	Spring Washer	272-00070	2	2	2	
10	Push-on Connector	064-33068/001	2	2	2	
11	Cover	064-33991/001	2	2	2	

Note:

For wiring cable loom refer to "Cable Loom - Protective Switches" (Code WC).

Illustration T80

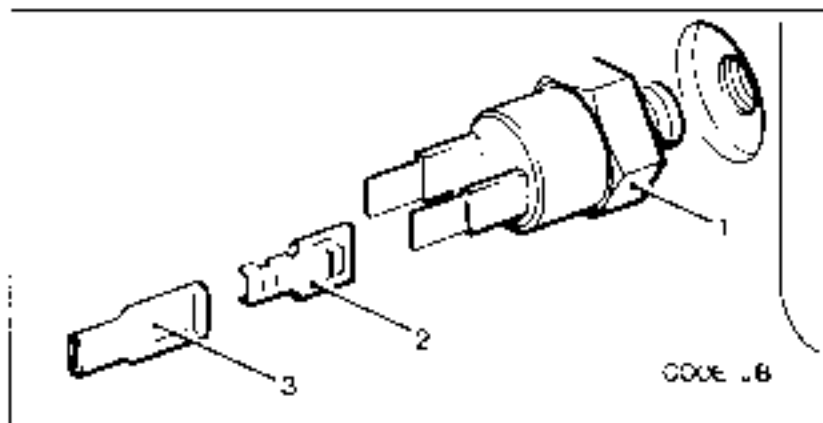
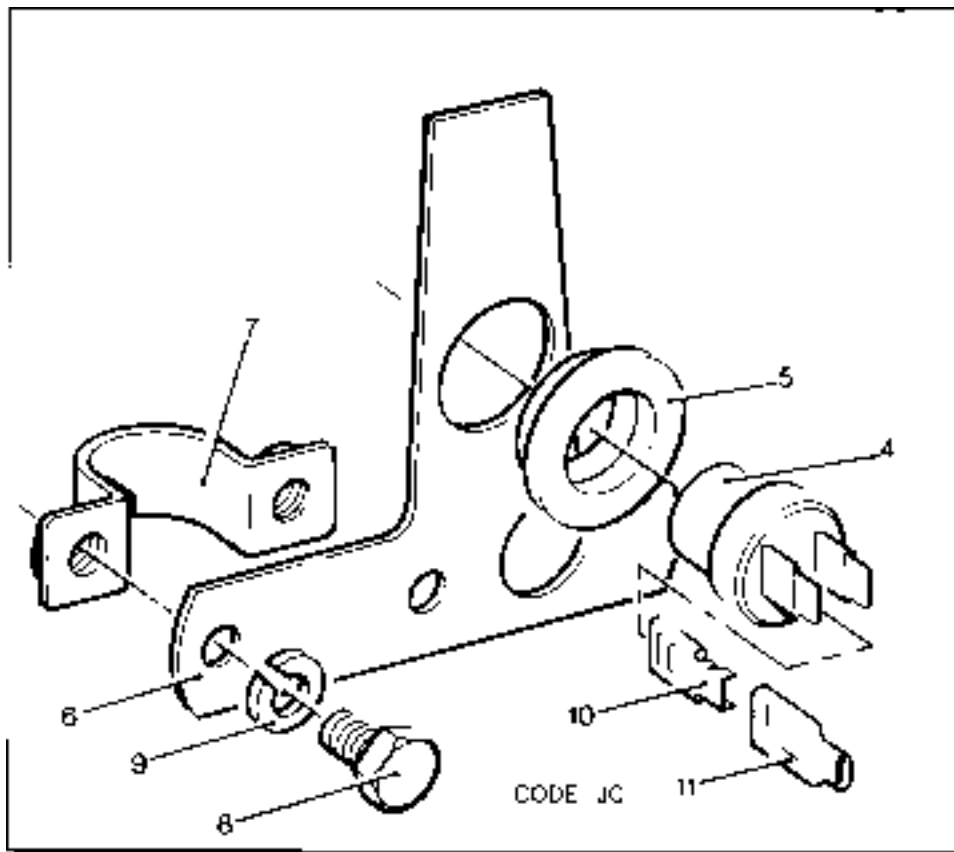

Oil Pressure Switch

Illustration T294 No. Description	Part Number	TS/TR			Remarks
		1	2	3	
Accessory Kit Code JD	570-30512	1	1	1	Includes code LG
1 Swivel Union Plug	366-07039	1	1	1	
2 Copper Washer	616-01608	2	2	2	
3 Flexible Pipe Assembly	366-07518	1	1	1	
4 Oil Distribution Block Assembly	366-07129	1	1	1	Replaces 366-07151
5 Washer	785515	4	4	4	
6 Setscrew - M10 x 25mm	272-00067	2	2	2	
7 Copper Washer	600-00106	2	2	2	
8 Oil Pressure Switch	757-15721	1	1	1	Replaces 757-15720 & 366-07040
9 Cover	757-17390	1	1	1	
10 Union	291-21141	1	1	1	
11 Setscrew	008-03019	1	1	1	
12 Push Button	366-06378	1	1	1	
13 Push-on Connector	757-14150	2	2	2	
14 Push-on Connector	064-33380/001	2	2	2	
15 Cover	064-33991/001	2	2	2	
16 Cable Link Assembly	366-06433	2	2	2	
17 Cable Assembly	366-06934	1	1	1	
18 Cable Assembly	366-06988	1	1	1	
19 Relay	382-07974	1	1	1	
20 Cheese Head Screw	064-06772/002	1	1	1	
21 Spring Washer	064-02582/002	1	1	1	
22 Nut	064-06611/003	1	1	1	
23 Cover	757-14160	2	2	2	

Note:

For wiring cable loom refer to "Cable Loom - Protective Switches" (Code WC).

Illustration T294

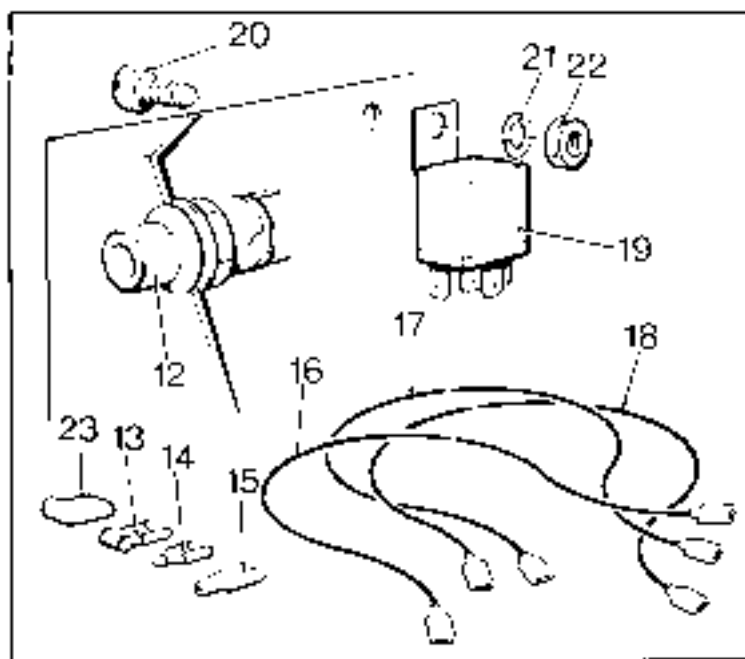
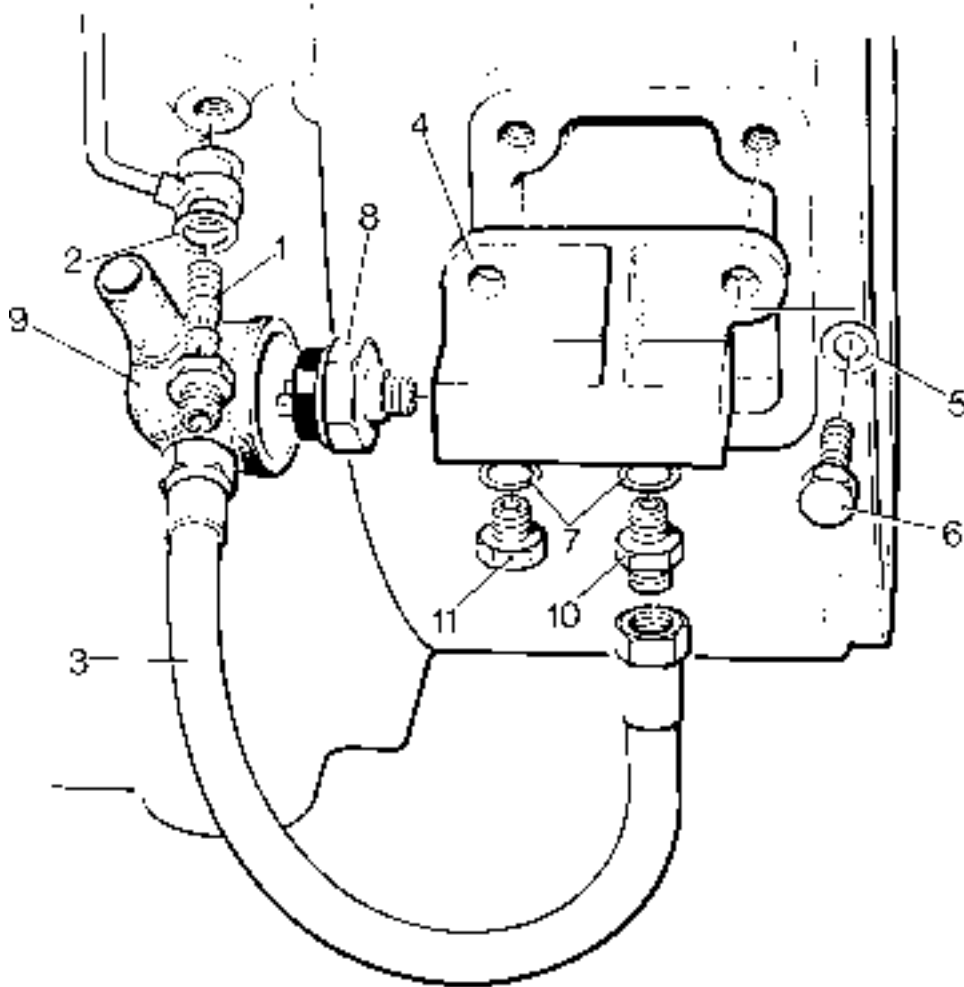

Fuel Control Solenoid - TS/TR2, 3

Illustration T356 No. Description	Part Number	TS/TR			Remarks
		1	2	3	
Accessory Kit Code JE	570-31882	-	1	1	
1 Solenoid - 12V	366-07197	-	1	1	
- Solenoid - 24V	366-07198	-	1	1	
2 Locking Nut	270-00002	-	1	1	
3 Solenoid Link Assembly	366-07913	-	1	1	
4 Bracket	366-07911	-	1	1	
5 Setscrew	272-00033	-	2	2	
6 Setscrew - M6 x 16mm	272-00034	-	2	2	
7 Spring Washer	272-00070	-	4	4	
8 Nut	272-00002	-	2	2	
9 Stopping Lever	366-07190	-	1	1	
10 Cheese Head Screw - M4 x 12mm	272-00062	-	2	2	
11 Safety Spring Washer	272-00084	-	2	2	
12 Cable Assembly	366-06906	-	1	1	
13 Connector	064-33068/002	-	1	1	
14 Cover	064-33991/002	-	1	1	
15 Cable Assembly	366-07204	-	1	1	
16 Cable Loom	366-07207	-	1	1	
17 Nylon Washer	366-08093	-	1	1	
18 Circuit Breaker - 12V 6A	366-08092	-	1	1	See Note
- Label	027-07893	-	1	1	
- Label	027-07894	-	1	1	

Note:

Circuit breaker replaces 10A fuse 382-08043 and holder 382-08042

Illustration T356

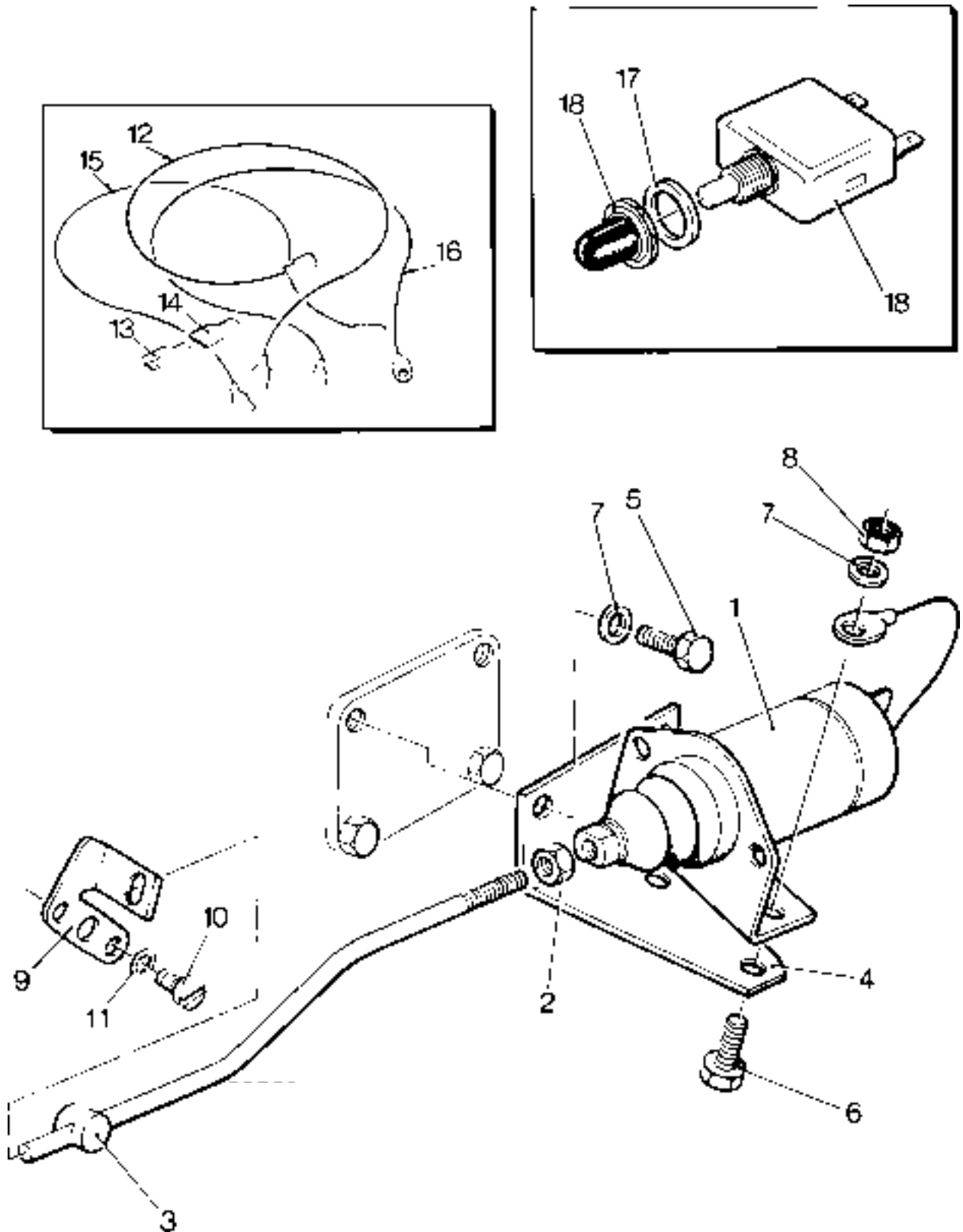

Fuel Control Solenoid - TS/TR1 (Later Type)

Illustration T427 No. Description	Part Number	TS/TR			Remarks
		1	2	3	
Accessory Kit Code JE	570-32841	1	-	-	
1 Solenoid - 12V	366-07197	1	-	-	
- Solenoid - 24V	366-07198	1	-	-	
2 Nut	270-00002	1	-	-	
3 Solenoid Link Assembly	366-07913	1	-	-	
4 Solenoid Support Bracket	366-08255	1	-	-	
5 Solenoid Mounting Bracket	366-08256	1	-	-	
6 Capscrew - M6 x 12mm	272-00167	1	-	-	
7 Lockwasher - 6mm	272-00086	1	-	-	
8 Setscrew - M10 x 20mm	272-00241	1	-	-	
9 Spring Washer	272-00072	1	-	-	
- Washer	027-00545	1	-	-	
10 Stopping Lever	366-07190	1	-	-	
11 Cheese Head Screw - M4 x 12mm	272-00062	2	-	-	
12 Safety Spring Washer	272-00084	2	-	-	
13 Setscrew - M6 x 16mm	272-00034	2	-	-	
14 Spring Washer	272-00070	2	-	-	
15 Nut	270-00002	2	-	-	
16 Cable Assembly	366-06906	1	-	-	
17 Connector	064-33068/002	1	-	-	
18 Cover	064-33991/002	1	-	-	
19 Cable Assembly	366-07204	1	-	-	
20 Cable Loom	366-07207	1	-	-	
21 Nylon Washer	366-08093	1	-	-	
22 Circuit Breaker - 12V 6A	366-08092	1	-	-	
- Label	027-07893	1	-	-	
- Label	027-07894	1	-	-	

Illustration T427

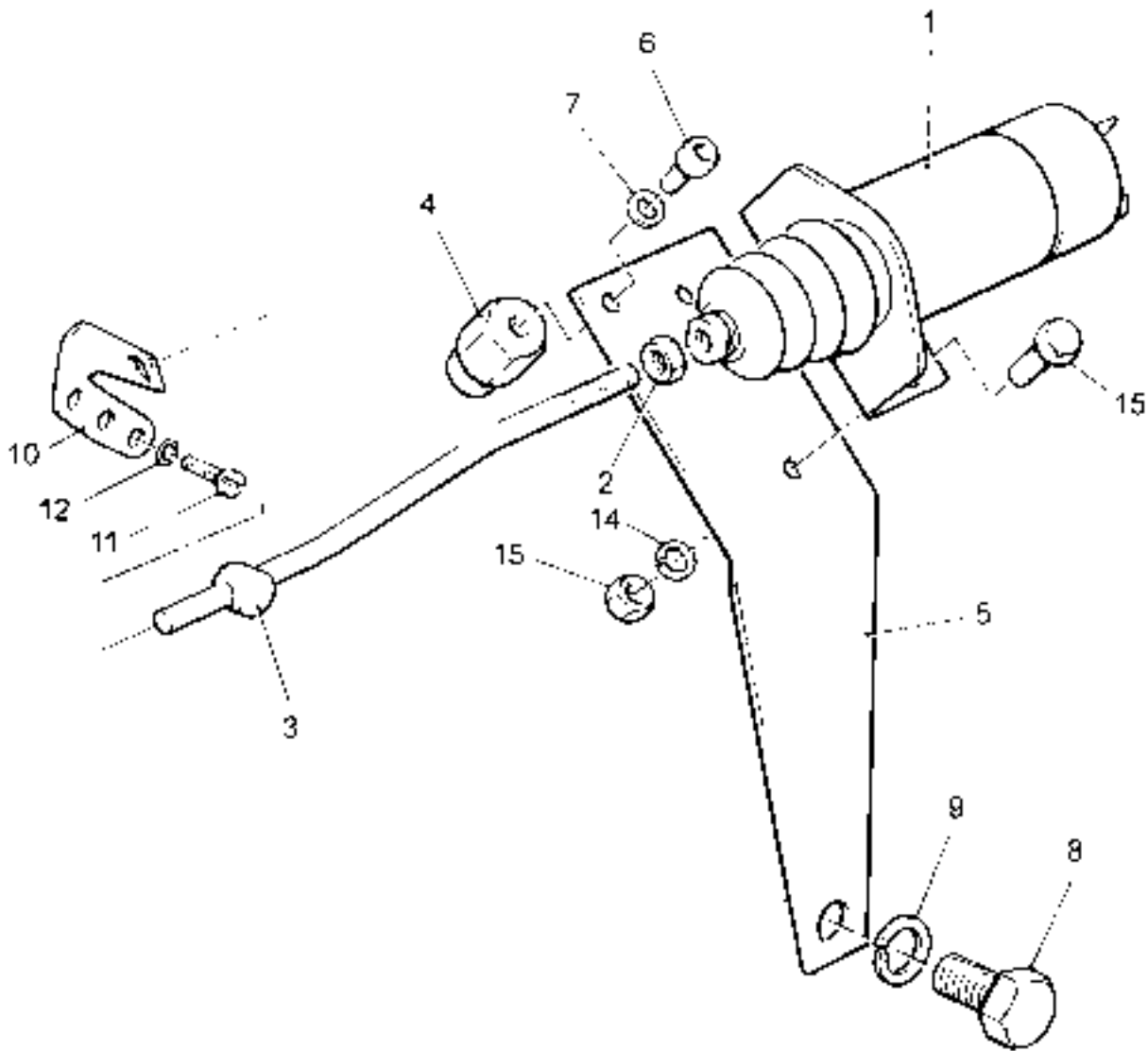
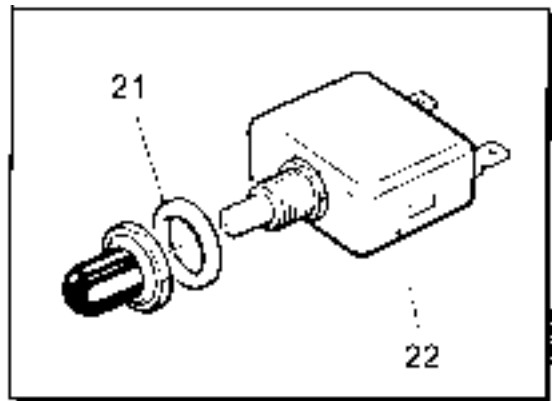
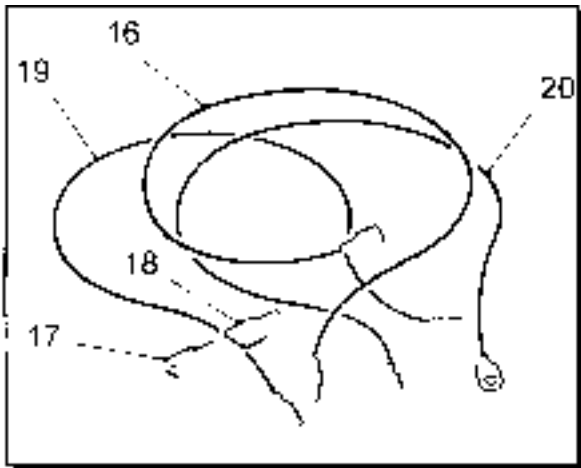

Gauge Panel

Illustration T99 No. Description	Part Number	TS/TR			Remarks
		1	2	3	
Accessory Kit Code PA	570-32421	1	1	1	
1 Gauge Panel - less gauges	382-07070	1	1	1	
2 Flexible Mounting	064-07640	3	3	3	
3 Spring Washer	064-02582/002	6	6	6	
4 Nut.....	064-06610/003	6	6	6	
5 Mounting Bracket	366-07042	1	1	1	
6 Setscrew - M10 x 25mm.....	272-00067	2	2	2	
7 Spring Washer	272-00072	2	2	2	
- Spacer - TS/TR1	396-18000	2	-	-	
8 Washer	027-00184	2	2	2	
9 Grommet	382-07342	1	1	1	

Illustration T99

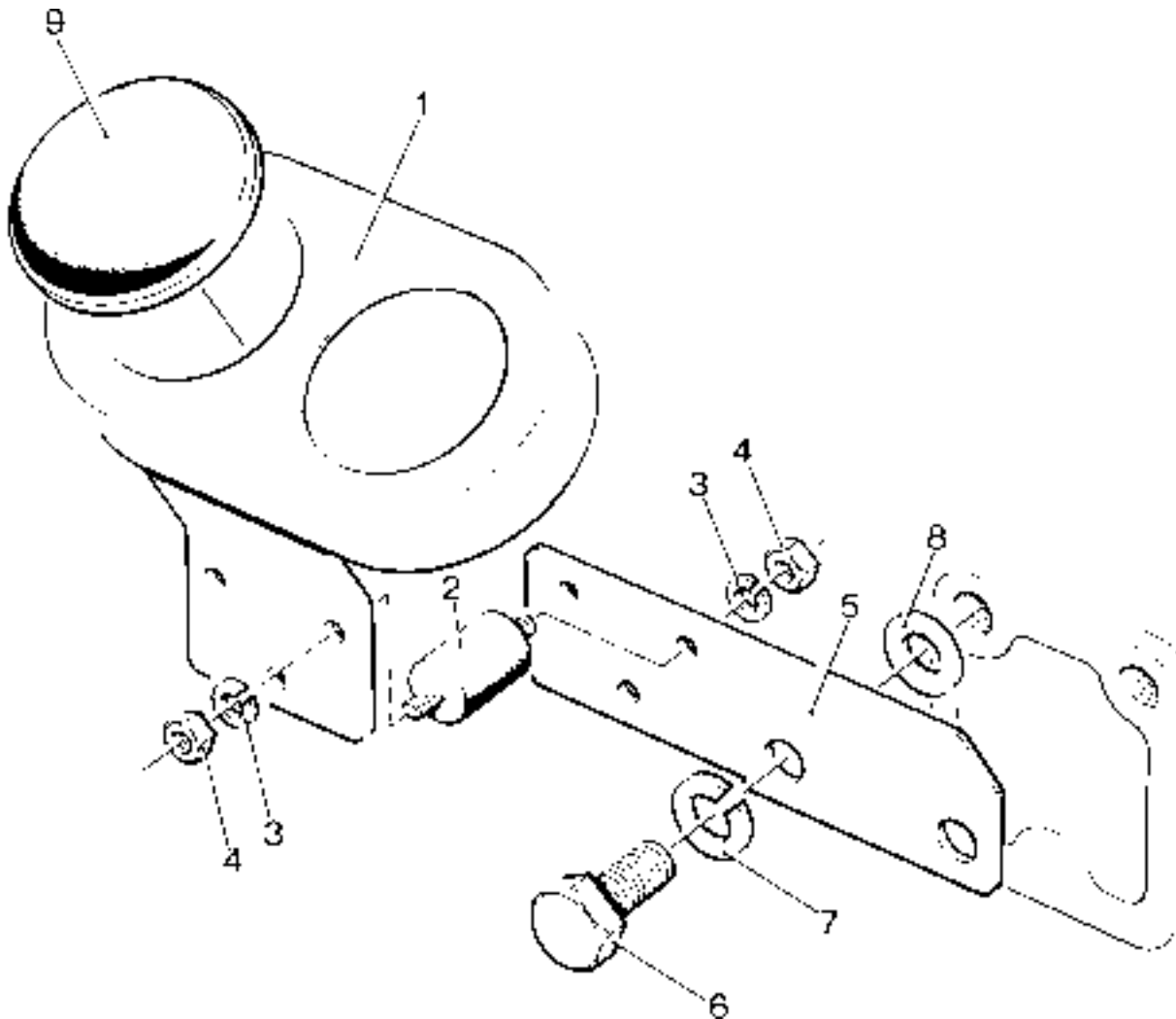

Oil Pressure Gauge - TS/TR1

Illustration T229
No. Description

TS/TR
Part Number 1 2 3 Remarks

1	Mounting Bracket	201-41160	1	-	-	
2	Setscrew - M6 x 12mm	272-00032	1	-	-	
3	Setscrew - M6 x 16mm	272-00034	2	-	-	
4	Spring Washer	272-00070	3	-	-	
5	Oil Pressure Gauge	351-15160	1	-	-	
6	Self-tapping Screw	291-37460	3	-	-	
7	Oil Pipe Assembly	201-41190	1	-	-	
8	Swivel Union Plug	366-07039	1	-	-	
9	Copper Washer	616-01608	1	-	-	

Illustration T229

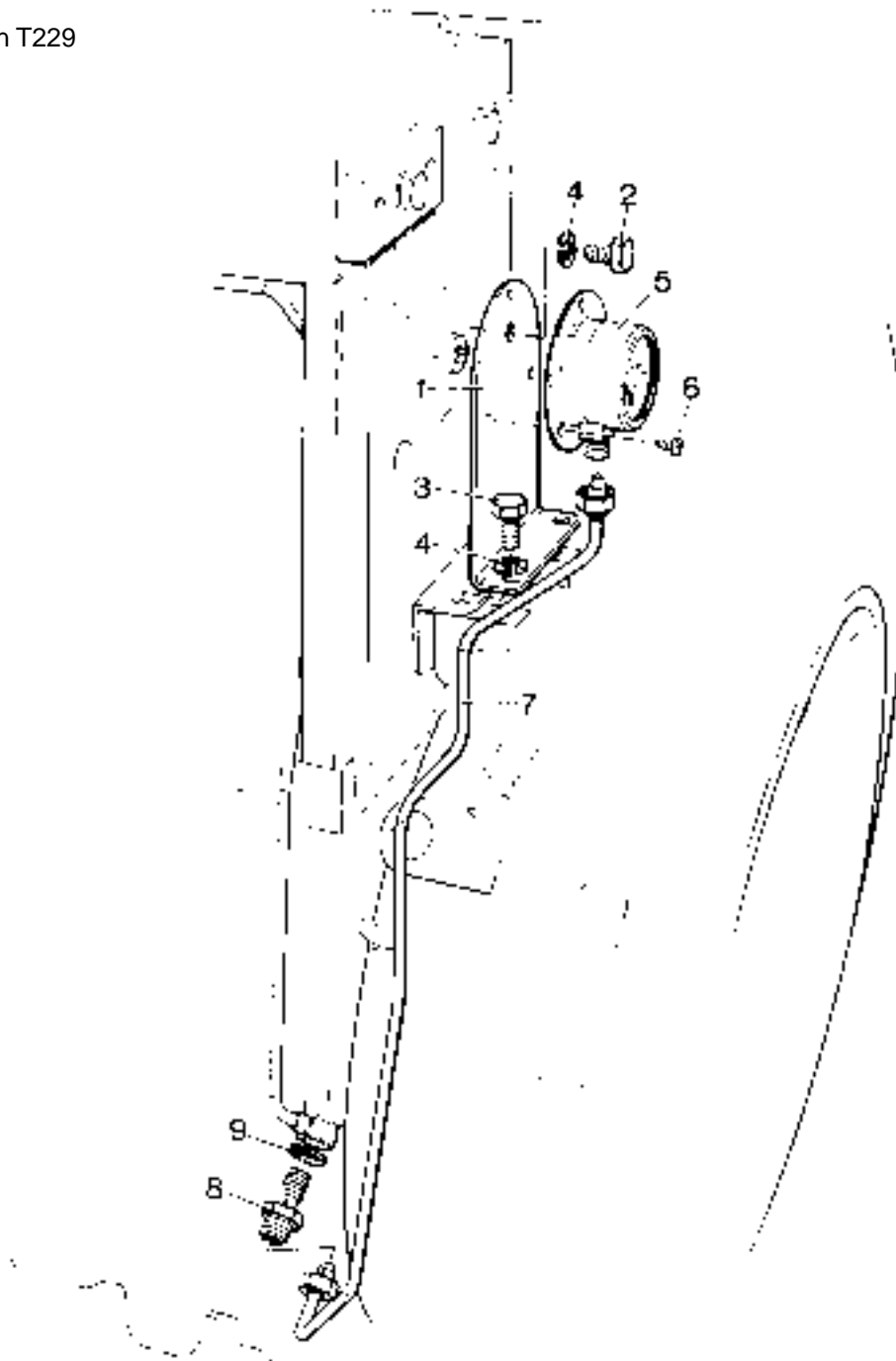

Oil Pressure Gauge

Illustration T104
No. Description

TS/TR
Part Number 1 2 3 Remarks

No.	Description	Part Number	1	2	3	Remarks
	Accessory Kit Code PE	570-32011	1	1	1	
1	Oil Pressure Gauge	370-12970	1	1	1	
2	Flexible Pipe	366-07044	1	1	1	
3	Swivel Union Plug	366-07039	1	1	1	
4	Copper Washer	616-01608	2	2	2	
-	Adaptor	291-37920	1	1	1	

Illustration T104

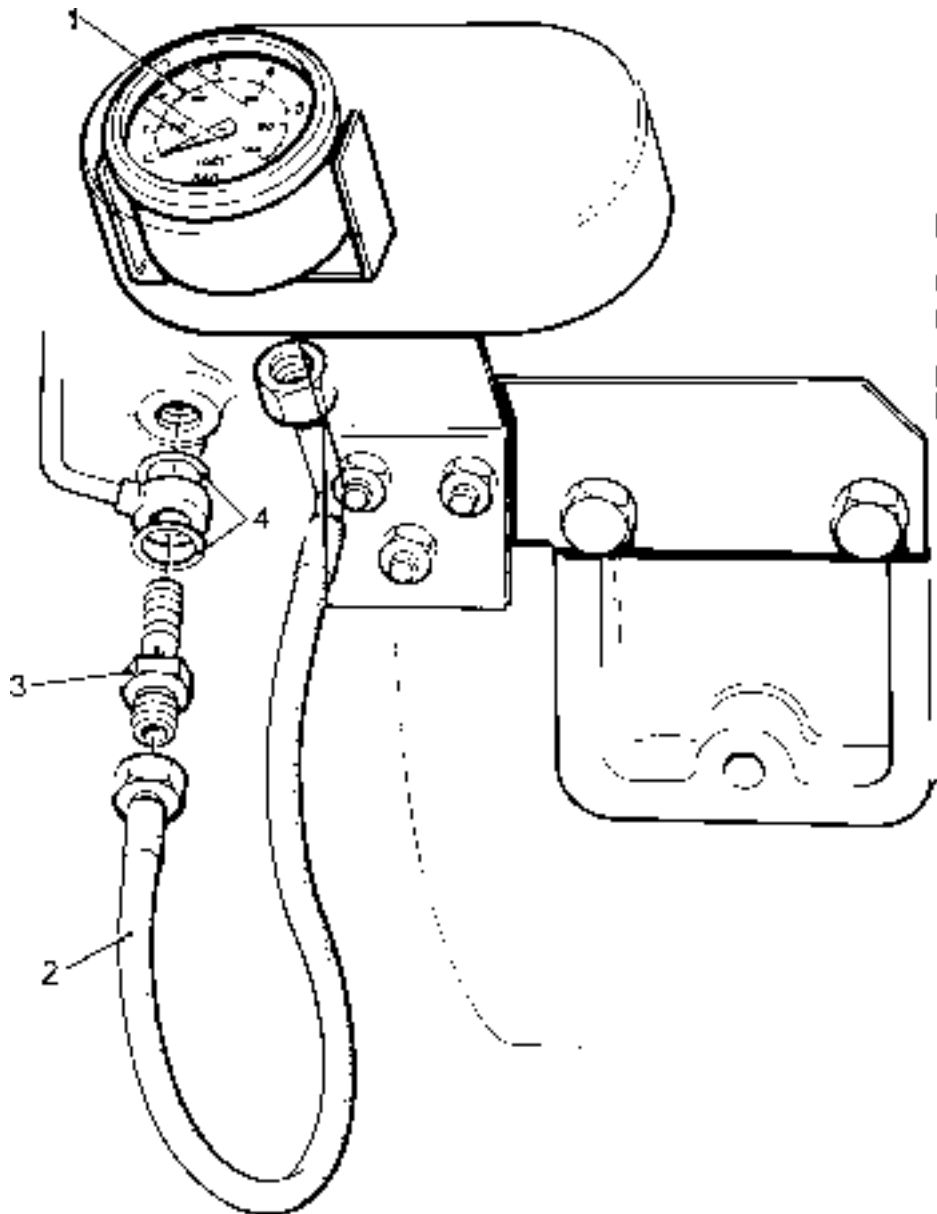

Temperature Gauge

Illustration T109
No. Description

TS/TR
Part Number 1 2 3 Remarks

	Accessory Kit Code PF	570-32020	1	1	1	
1	Temperature Gauge	370-12991	1	1	1	
2	Probe Mounting Bracket	202-36670	1	1	1	
3	Clamp	382-08102	1	1	1	
4	Setscrew - M6 x 12mm	272-00032	2	2	2	
5	Spring Washer	272-00070	2	2	2	
6	Locknut	027-00017	1	1	1	
7	Cable Tie	064-32790/001	4	4	4	

Illustration T109

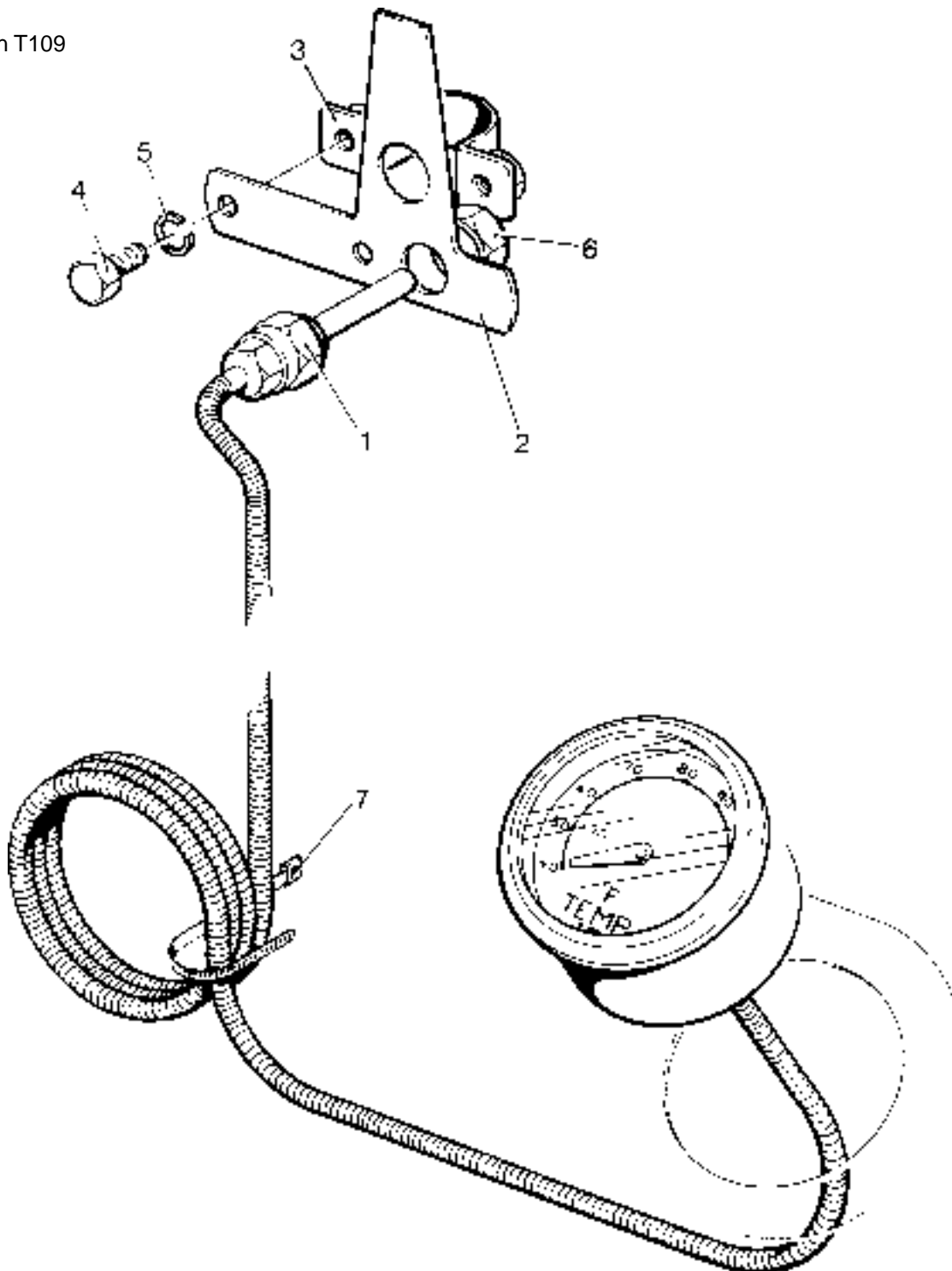

Vibration Running Hour Recorder

Illustration T110
No. Description

Part Number TS/TR
1 2 3 Remarks

	Accessory Kit Code PK	570-32030	1	1	1	
1	Bracket	202-36530	1	1	1	
2	Vibration Hour Recorder	636-21651	1	1	1	
3	Spacer	351-22010	2	2	2	
4	Spring Washer	272-00070	2	2	2	
5	Bolt - M6 x 35mm	272-00191	2	2	2	

Illustration T110

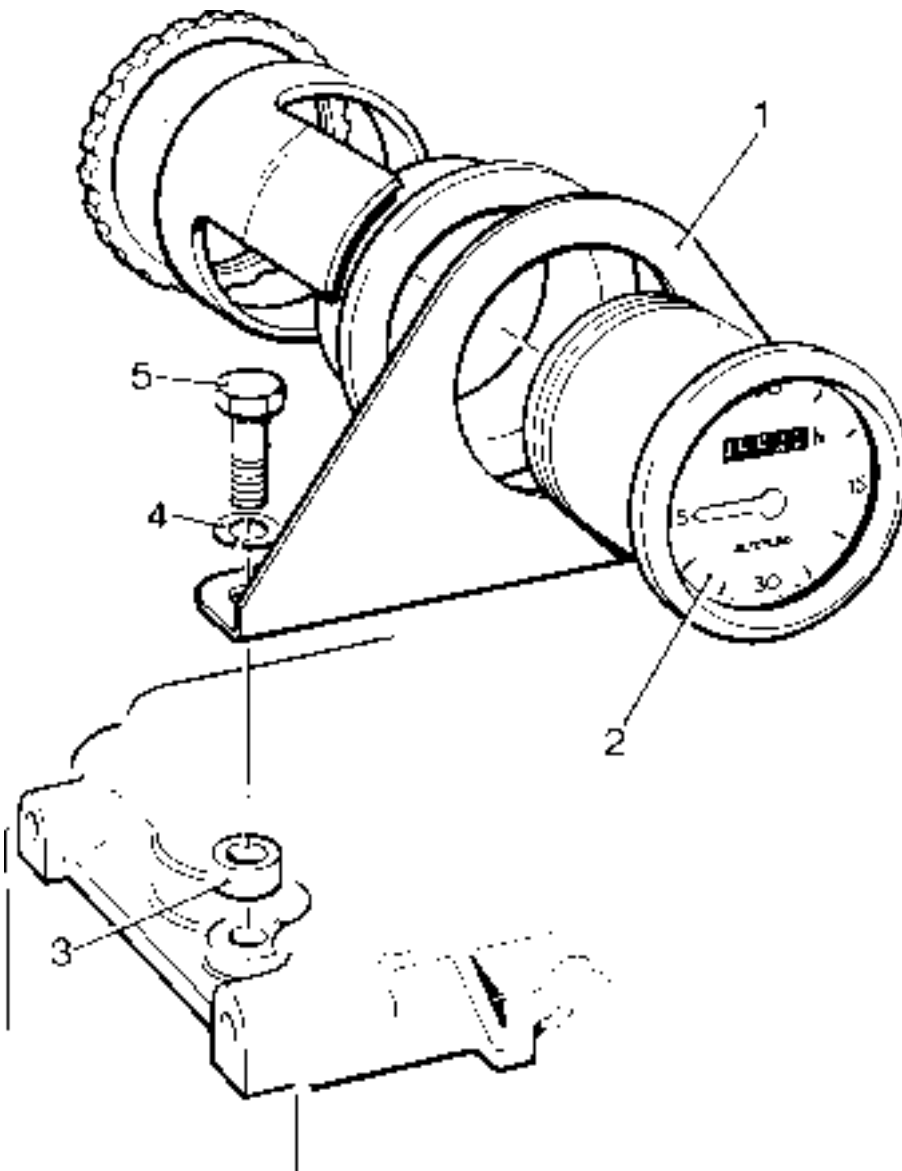

Electrical Running Hour Recorder

Not Illustrated Description	Part Number	TS/TR			Remarks
		1	2	3	
Accessory Kit Code PG	570-30520	1	1	1	
Electrical Running Hour Recorder	757-14501	1	1	1	Replaces 367-14074
Cable	691-01355	1	1	1	
Cable	366-06966	1	1	1	

Ammeter

Not Illustrated Cannot be used with Nicsa charging system Description	Part Number	TS/TR			Remarks
		1	2	3	
Ammeter	291-37050	1	1	1	
Terminal	064-15649/007	2	2	2	
Cable	366-07324	1	1	1	

Air Cleaner - Paper Element

Illustration T295
No. Description

TS/TR
Part Number 1 2 3 Remarks

No.	Description	Part Number	1	2	3	Remarks
	Accessory Kit Code AA - TS/TR1	570-33740	1	-	-	
	Accessory Kit Code AA - TS/TR2,3	570-31381	-	1	1	TR3 up to 1800 r/min
	Accessory Kit Code AO - TS/TR3	570-36100	-	-	1	TR3 above 1801 r/min
1	Air Cleaner - TS/TR1	366-07028	1	-	-	
1	Air Cleaner - TS/TR2,3	366-07186	-	1	1	TR3 up to 1800r/min
-	Air Cleaner - TR3	366-07721	-	-	1	TR3 above 1801r/min
2	Element	366-07188	1	1	1	TR3 up to 1800r/min
-	Element	366-07723	-	-	1	TR3 above 1801r/min
3	Clip	365250	1	1	1	
4	Sleeve	366-08094	1	1	1	Not part of kit
5	Hose Clip	027-04234	1	1	1	Not part of kiT

Illustration T295

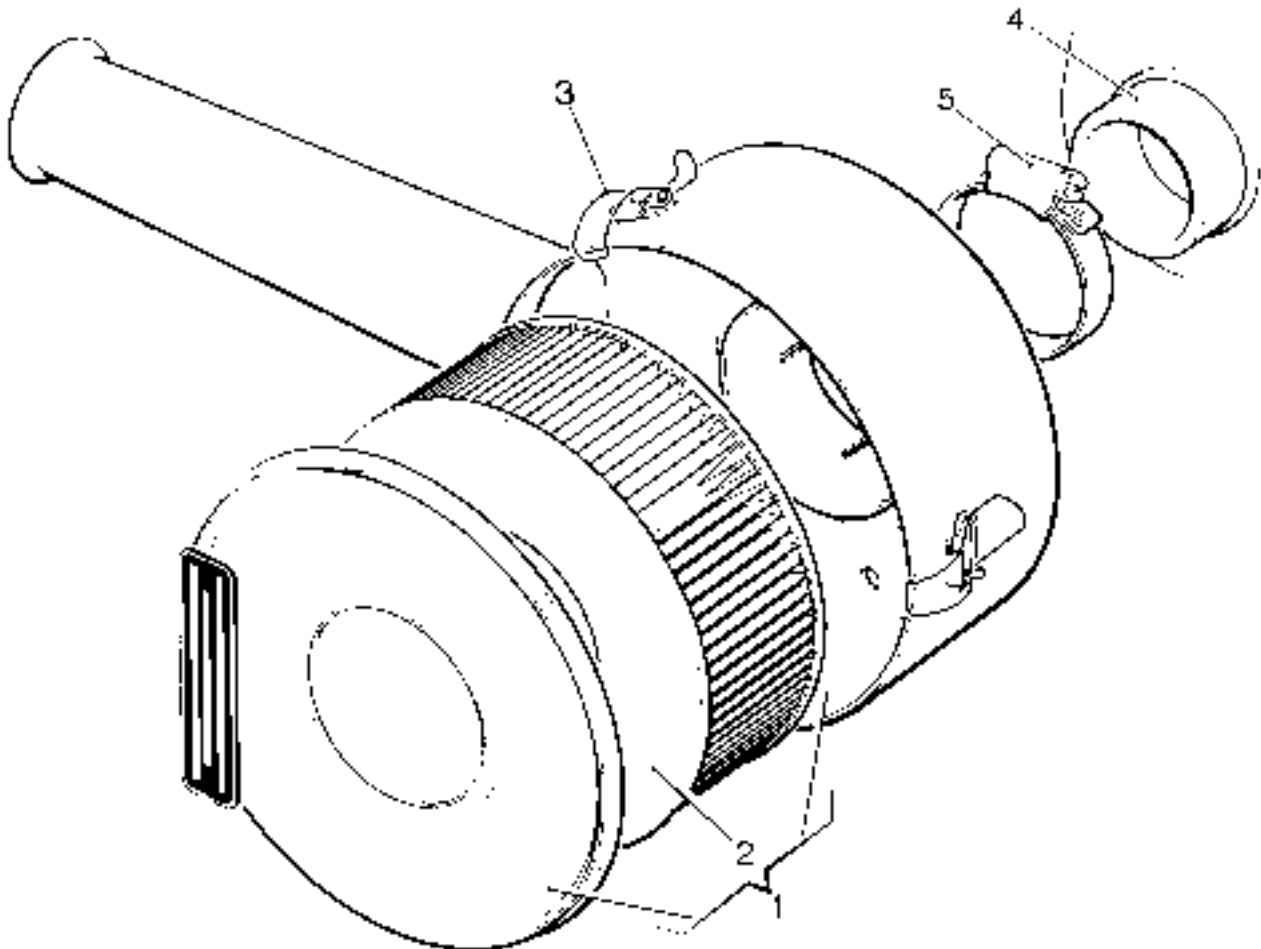

Air Cleaner - Foam Element - TS/TR2,3

Illustration T184
No. Description

TS/TR
Part Number 1 2 3 Remarks

No.	Description	Part Number	1	2	3	Remarks
	Accessory Kit Code AB	570-31391	-	1	1	
1	Air Cleaner - TS/TR2,3	366-07187	-	1	1	
2	Element	366-07189	-	1	1	
3	Clip	365250	-	1	1	
4	Sleeve	366-08094	-	1	1	Not part of kit
5	Hose Clip	027-04234	-	1	1	Not part of kit

Illustration T184

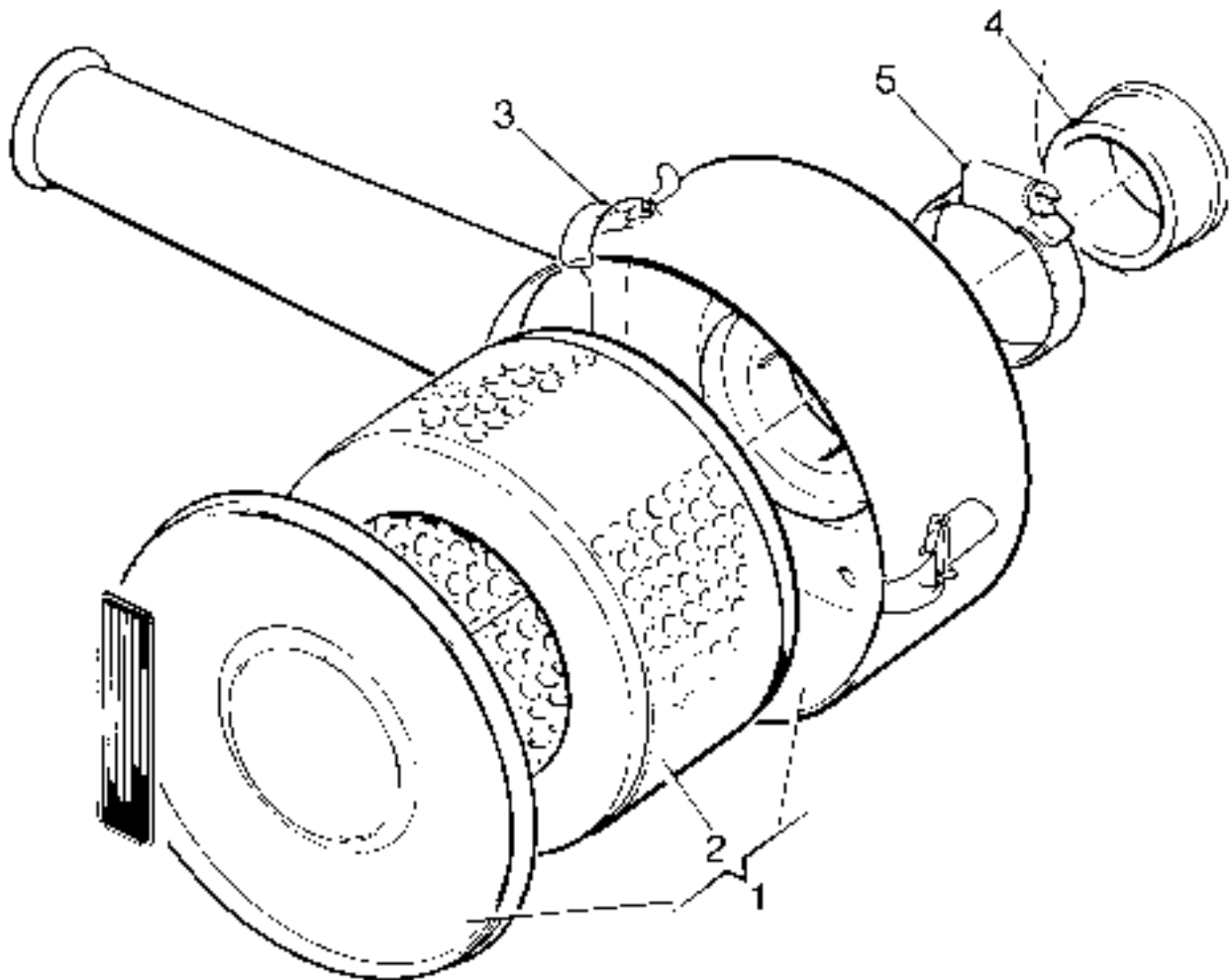

Heavy Duty Air Cleaner - TS/TR1

Replaced from 4200531TS1 by Cyclonic type

Illustration T337

No.	Description	Part Number	TS/TR			Remarks
			1	2	3	
1	Inlet Manifold	201-37861	1			
2	Joint	201-33420	2	-	-	One each side of the air cowling
3	Stud - M6 x 30mm	272-00304	2	-	-	
-	Spring Washer	272-00070	2	-	-	
-	Nut	272-00379	2	-	-	
4	Mounting Bracket	201-42800	1	-	-	
5	Steady Bracket	201-44680	1	-	-	
6	Bolt - M6 x 35mm	272-00191	2	-	-	For fuel filter fixing
7	Spacer	202-33960	2	-	-	
8	Spring Washer	272-00070	2	-	-	
9	Setscrew - M6 x 16mm	272-00034	3	-	-	
10	Spring Washer	272-00070	3	-	-	
11	Setscrew - M8 x 25mm	272-00040	1	-	-	
12	Spring Washer	272-00071	1	-	-	
13	Mounting Band Assembly	382-04373	2	-	-	
14	Setscrew - M8 x 20mm	272-00039	4	-	-	
15	Spring Washer	272-00071	4	-	-	
16	Nut	272-00003	4	-	-	
17	Air Cleaner	602-41740	1	-	-	
18	Element	602-41760	1	-	-	
19	Cover	201-39000	1	-	-	
20	Tube	201-42770	1	-	-	
21	Air Inlet Hose	201-38990	2	-	-	
22	Hose Clip	027-04234	4	-	-	
23	Inlet Cap	382-04372	1	-	-	

Illustration T337

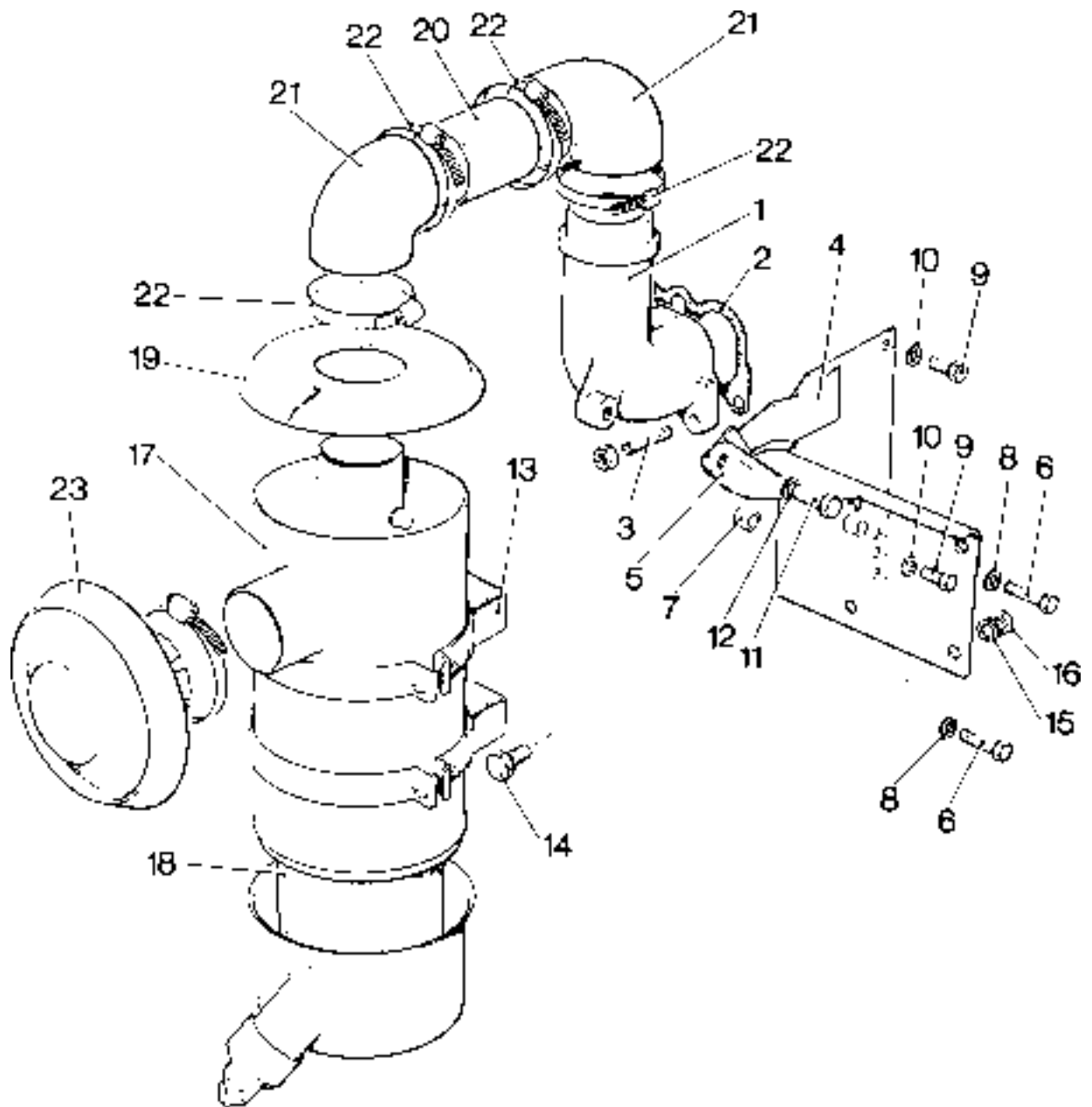

Cyclonic Air Cleaner - TS/TR1

Front Mounted from 4200531TS1

Illustration T406

No.	Description	Part Number	TS/TR			Remarks
			1	2	3	
	Accessory Kit Code AC	570-41580	1	-	-	Not for use with code FB
1	Inlet Manifold	201-37861	1	-	-	
2	Joint	201-33420	1	-	-	
3	Stud - M6 x 30mm	272-00304	1	-	-	
-	Spring Washer	272-00070	1	-	-	
-	Nut	272-00379	1	-	-	
4	Mounting Bracket	366-08085	1	-	-	
5	Bolt - M6 x 30mm	272-00035	2	-	-	For fuel filter fixing
6	Spacer	601-41700	2	-	-	
7	Spring Washer	272-00070	2	-	-	
8	Setscrew - M6 x 16mm	272-00034	3	-	-	
9	Spring Washer	272-00070	3	-	-	
10	Setscrew - M8 x 25mm	272-00040	1	-	-	
11	Spring Washer	272-00071	1	-	-	
12	Setscrew - M8 x 20mm	272-00039	2	-	-	
13	Spring Washer	272-00071	2	-	-	
14	Nut	272-00003	2	-	-	
15	Air Cleaner Assembly	366-08107	1	-	-	
16	Main Element	366-08105	1	-	-	
17	Safety Element	366-08106	1	-	-	
18	Hose Clip	027-04234	4	-	-	
19	Tube	201-42770	1	-	-	
20	Air Inlet Hose	201-38990	2	-	-	

Illustration T406

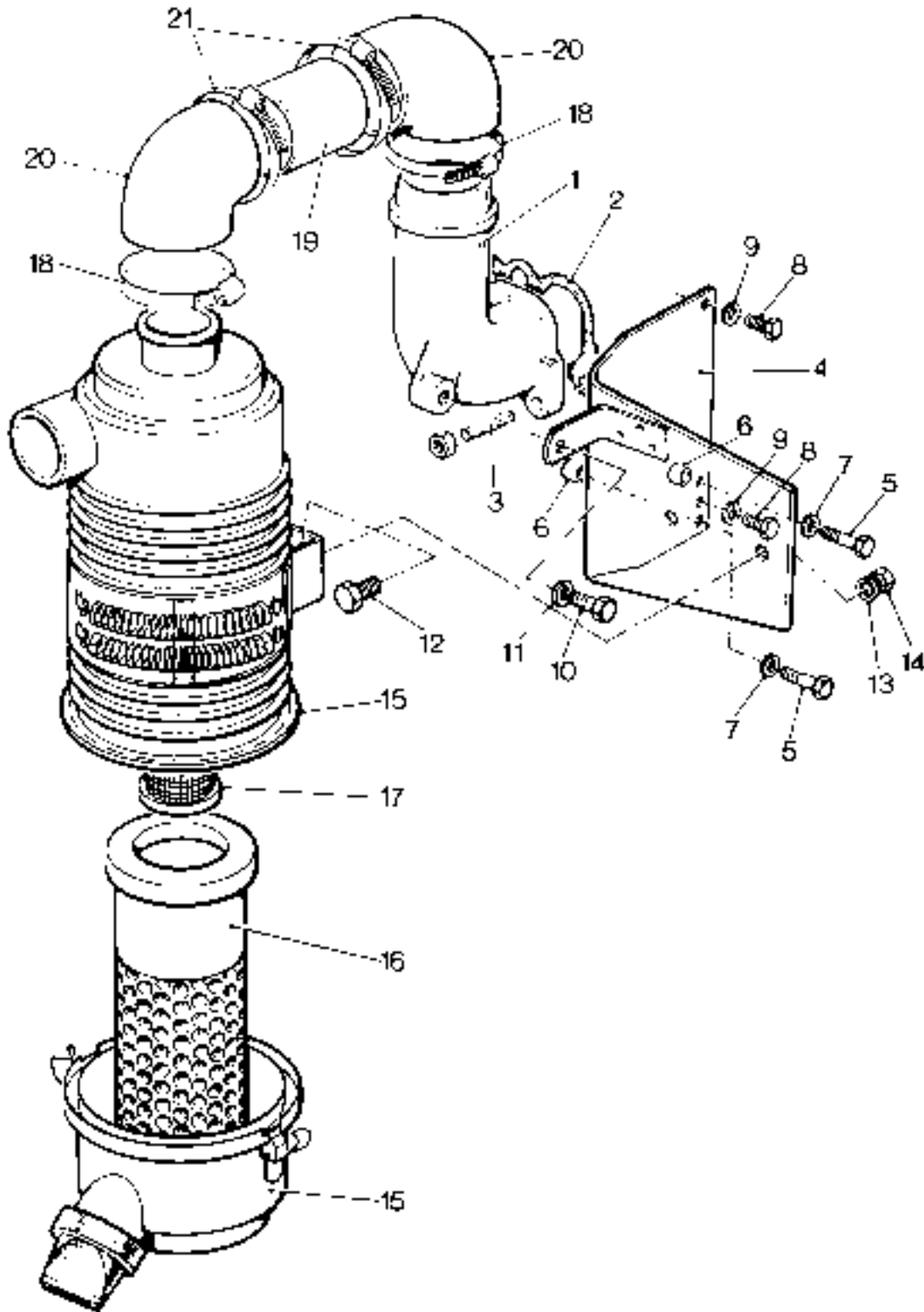

Medium Duty Dry Type Air Cleaner - TS/TR1

Illustration T417

No. Description

Part Number

TS/TR

1 2 3 Remarks

	Accessory Kit Code AJ	570-33750	1	-	-	
1	Air Cleaner - 8"	366-07028	1	-	-	
-	Element	366-07188	1	-	-	
2	Vertical Air Inlet Manifold	201-37861	1	-	-	
3	Stud - M6 x 30mm	272-00304	1	-	-	
4	Manifold Joint	201-33420	1	-	-	

Illustration T417

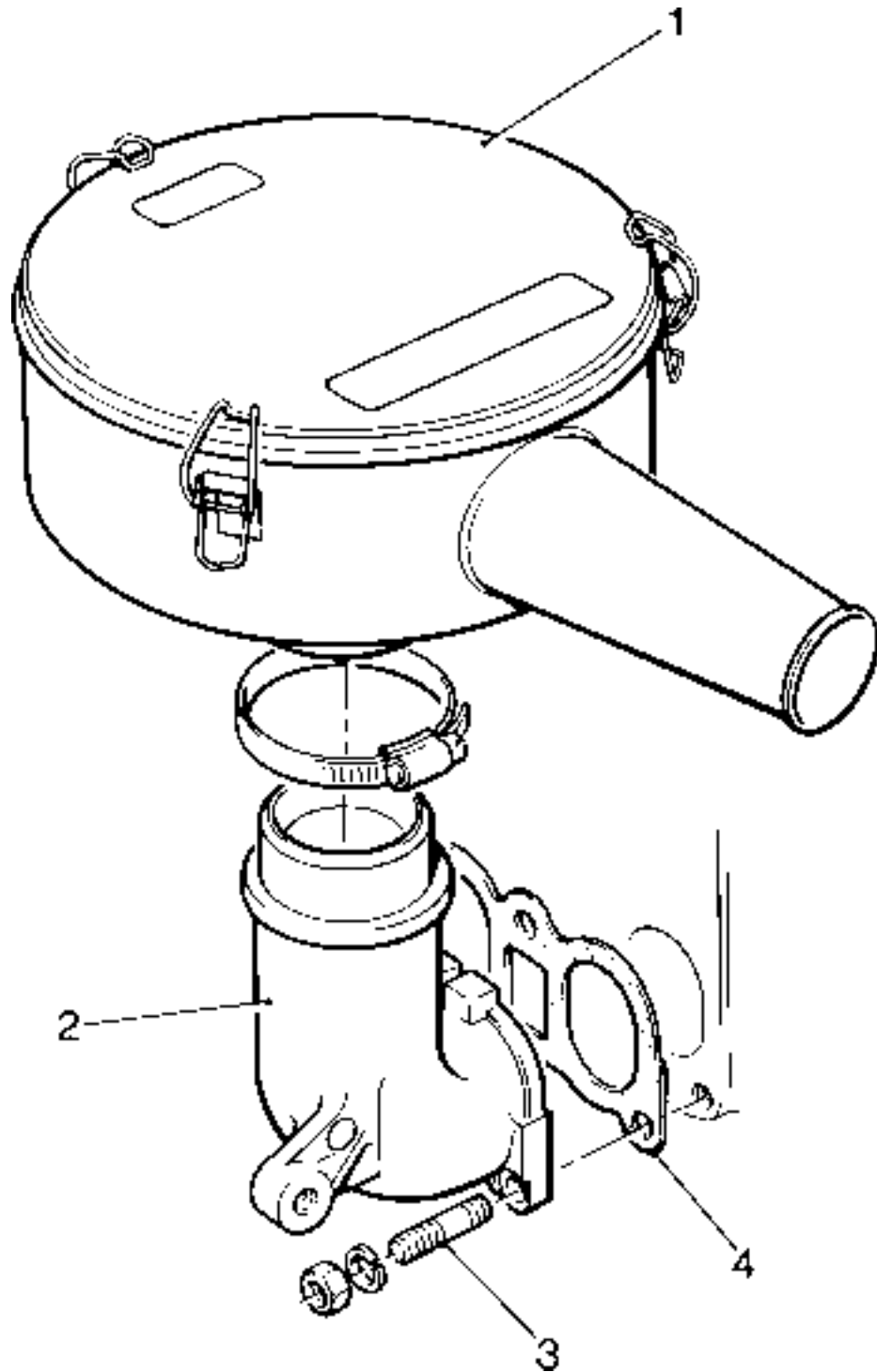

6 1/2" Side Mounted Cyclonic Air Cleaner - TS/TR2,3

TR3 Engines up to 2500 r/min only

Illustration T235

No.	Description	Part Number	TS/TR			Remarks
			1	2	3	
-	Air Cleaner Kit - 2 Cyl	570-34230	-	1	-	
-	Air Cleaner Kit - TS3	570-34250	-	-	1	
-	Air Cleaner Kit - TR3	570-41330	-	-	1	
1	Air Cleaner Assembly	366-07280	-	1	1	
2	Element	366-07282	-	1	1	
3	Mounting Band	382-04377	-	2	2	
4	Manifold Adaptor	366-07202	-	1	1	
5	Joint	202-33231	-	1	1	
-	Mounting Plate - 2 Cyl	366-07437	-	1	-	
6	Mounting Plate - 3 Cyl	366-07283	-	-	1	
7	Setscrew - M8 x 20mm	272-00039	-	2	2	
8	Spring Washer	272-00071	-	2	2	
9	Setscrew - M10 x 20mm	272-00241	-	4	4	
10	Spring Washer	272-00072	-	4	4	
11	Nut - M10	272-00004	-	4	4	
-	Hose - 2 Cyl	203-35580	-	1	-	
12	Hose - 3 Cyl	366-05870	-	-	1	
13	Hose Clip	027-04234	-	2	2	
14	Fanshroud - TS2-3/TR2	366-07227	-	1	1	See Note
-	Fanshroud - TR3	366-08048	-	-	1	See Note
15	Lock Washer	201-30950	-	6	6	
-	Spring Washer - TR3	272-00070	-	-	3	

Note:

Must be fitted to allow air cleaner mounting.

Illustration T235

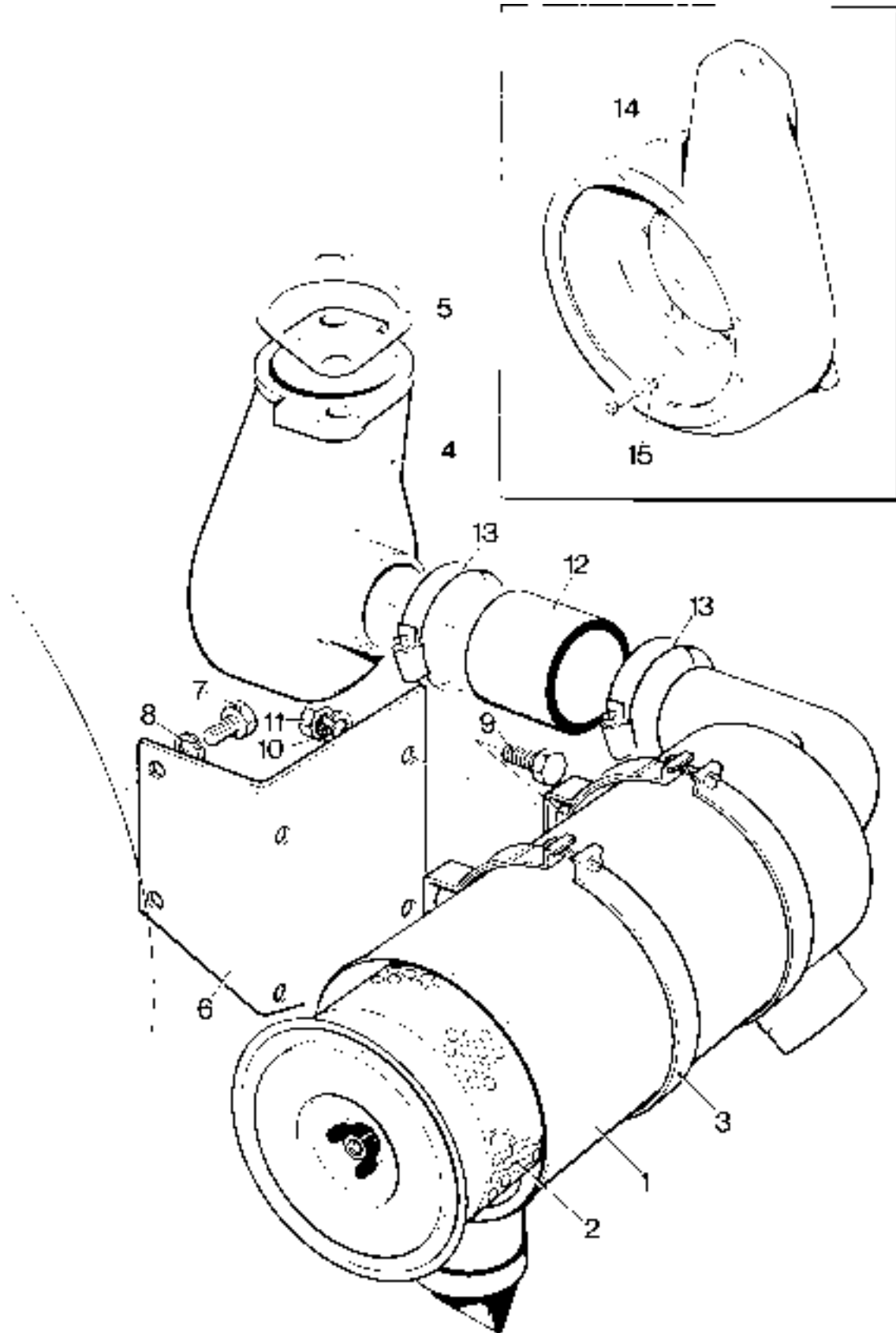

7" Side Mounted Cyclonic Air Cleaner - TS/TR2,3

Illustration T394
No. Description

No.	Description	Part Number	TS/TR			Remarks
			1	2	3	
	Accessory Kit Code AD - TS/TR2	570-35651	-	1	-	
	Accessory Kit Code AD - TS/TR3	570-35652	-	-	1	
1	Air Cleaner Assembly	366-08108	-	1	1	
2	Main Element	366-08109	-	1	1	
3	Safety Element	366-08110	-	1	1	
4	Hose Clip	027-04234	-	1	1	
5	Sleeve	366-08094	-	1	1	
6	Mounting Bracket - TS/TR2	201-47330	-	1	-	Replaces 366-08075, See Note
-	Mounting Bracket - TS/TR3	201-47330	-	-	1	Replaces 366-08103, See Note
7	Setscrew - M8 x 20mm	272-00039	-	4	4	
8	Spring Washer	272-00071	-	4	4	
9	Nut	272-00003	-	2	2	
10	Air Inlet Hose	366-08098	-	1	1	
11	Hose Clip	027-04696	-	1	1	
12	Fanshroud	366-07227	-	1	1	See Note

Note:

Latest kits only suitable for engines fitted with 13.5 litre tanks - mounted vertically instead of horizontally. (Heatshield and special Fanshroud no longer needed).

Illustration T394

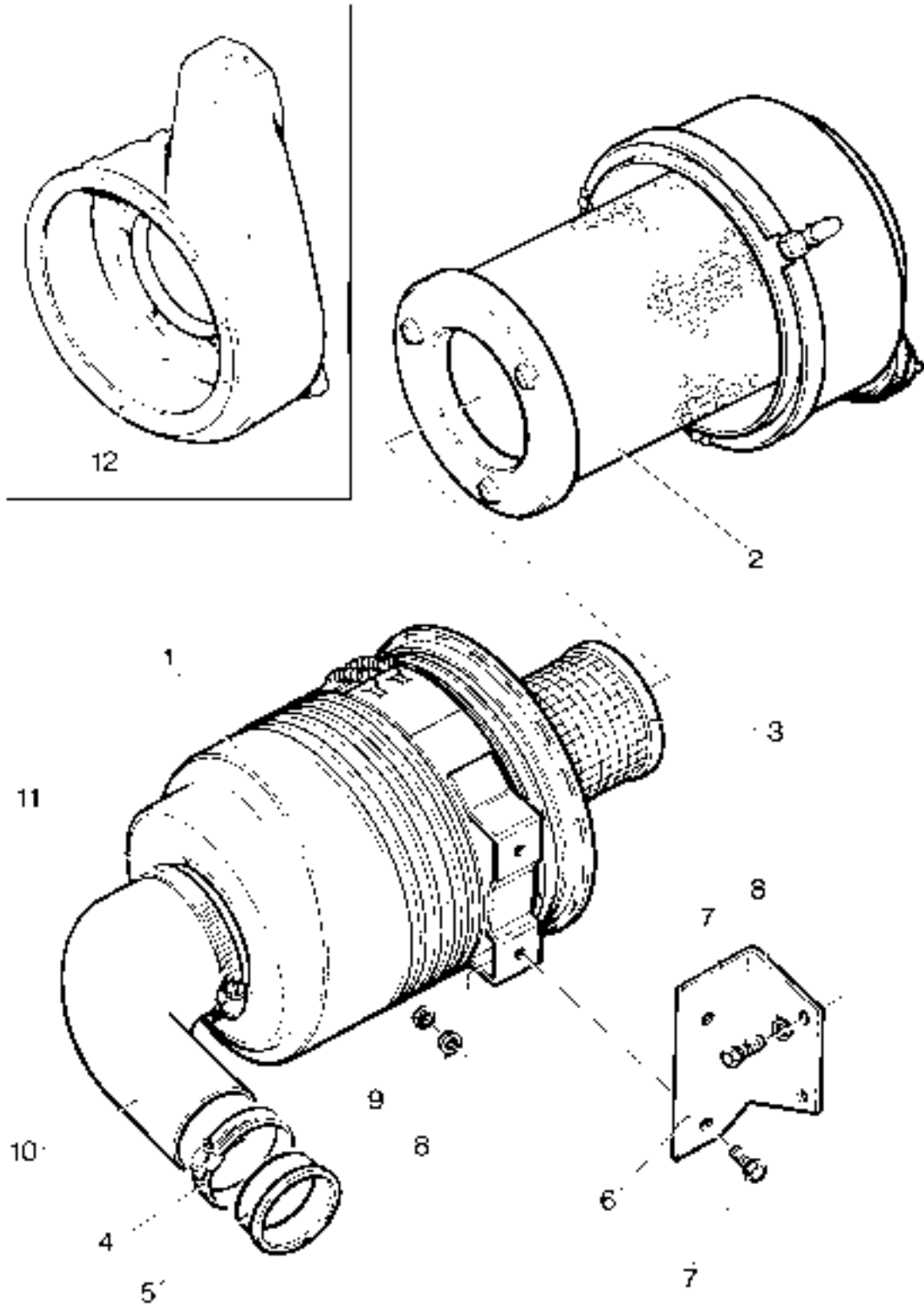

6 1/2" Front Mounted Heavy Duty Cyclonic Air Cleaner - TS/TR2,3

Illustration T197

No. Description

Part Number

TS/TR

1 2 3 Remarks

1	Air Cleaner	366-07008	-	1	1	See Note
2	Element	202-33380	-	1	1	
3	Joint.....	202-33230	-	1	1	
4	Stud - M8 x 35mm	272-00266	-	2	2	
5	Spring Washer	272-00071	-	2	2	
6	Nut.....	272-00003	-	2	2	
7	Pre-cleaner	382-07900	-	1	1	
8	Setscrew - M8 x 16mm	272-00038	-	1	1	
9	Spring Washer	272-00071	-	1	1	

Note:

Air cleaner no longer available.

To convert to current 7" cyclonic air cleaner (Code AE) use Conversion Kit SK2150/90

Illustration T197

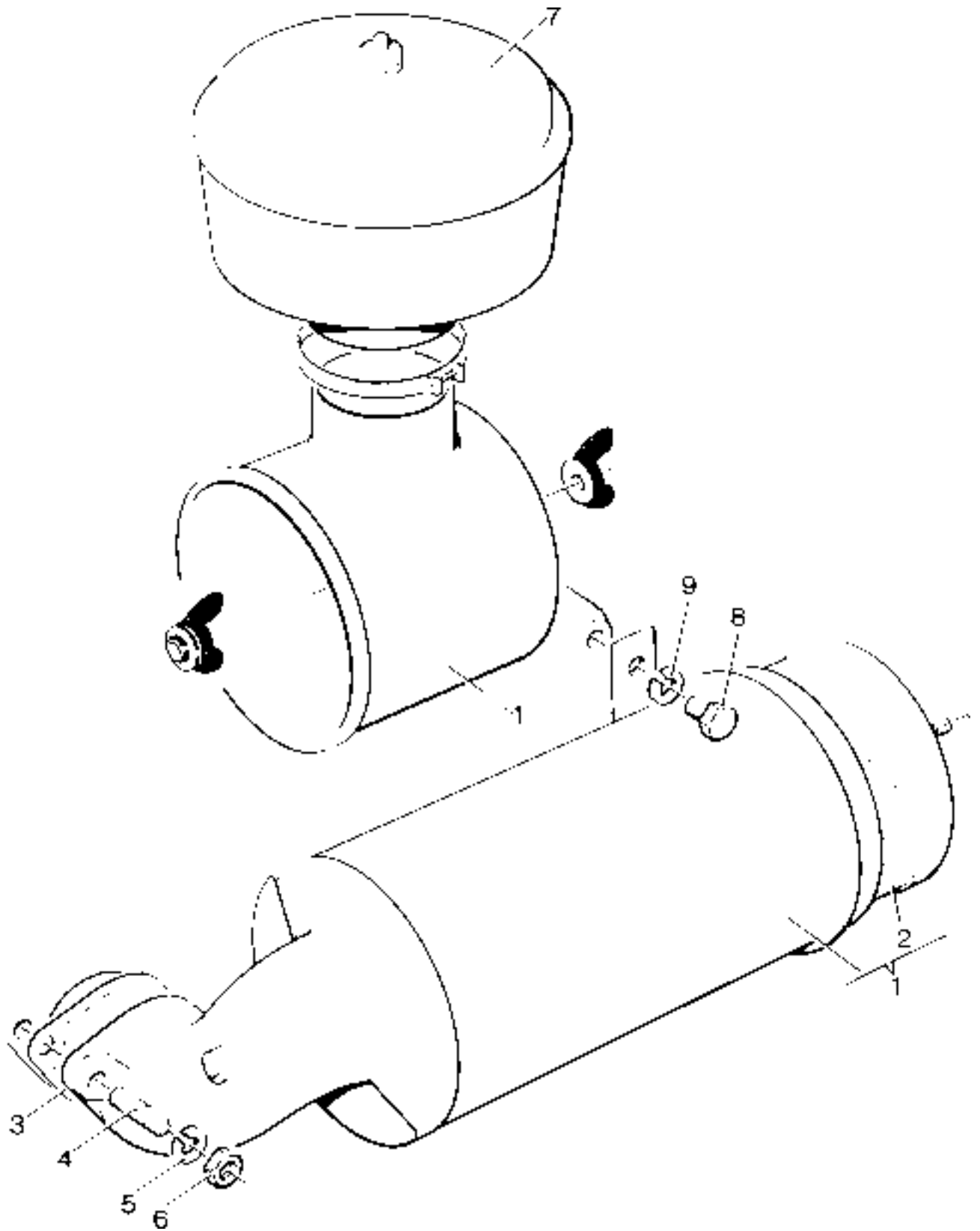

7" Front Mounted Cyclonic Air Cleaner - TS/TR2,3

Illustration T397

First fitted on the following engines:

4103375TS2 4200321TR2

4103291TS3 4100643TR3

No.	Description	Part Number	TS/TR			Remarks
			1	2	3	
	Accessory Kit Code AE - TS/TR2	570-41611	-	1	-	
	Accessory Kit Code AE - TS/TR3	570-41612	-	-	1	
1	Air Cleaner Assembly	366-08108	-	1	1	
2	Main Element	366-08109	-	1	1	
3	Safety Element	366-08110	-	1	1	
4	Hose Clip	027-04696	-	1	1	
5	Mounting Plate	366-08101	-	1	1	
6	Spacer	027-07804	-	3	3	
7	Bolt - M6 x 30mm	272-00035	-	2	2	
8	Washer	027-00618	-	8	8	
9	Air Inlet Manifold - TS/TR2	202-31004	-	1	-	
-	Air Inlet Manifold - TS/TR3	203-31005	-	-	1	
10	Air Inlet Hose	366-08099	-	1	1	
11	Hose Clip	027-04234	-	1	1	
12	Setscrew - M8 x 20mm	272-00039	-	2	2	
13	Spring Washer	272-00071	-	2	2	
14	Nut	272-00003	-	2	2	
15	Bracket	201-38071	-	1	1	
16	Spring Washer	272-00070	-	1	1	
17	Nut	272-00002	-	1	1	
18	Bolt - M6 x 35mm	272-00191	-	1	1	
19	Washer	027-00082	-	1	1	
20	Bolt - M8 x 80mm	272-00128	-	1	1	

Illustration T397

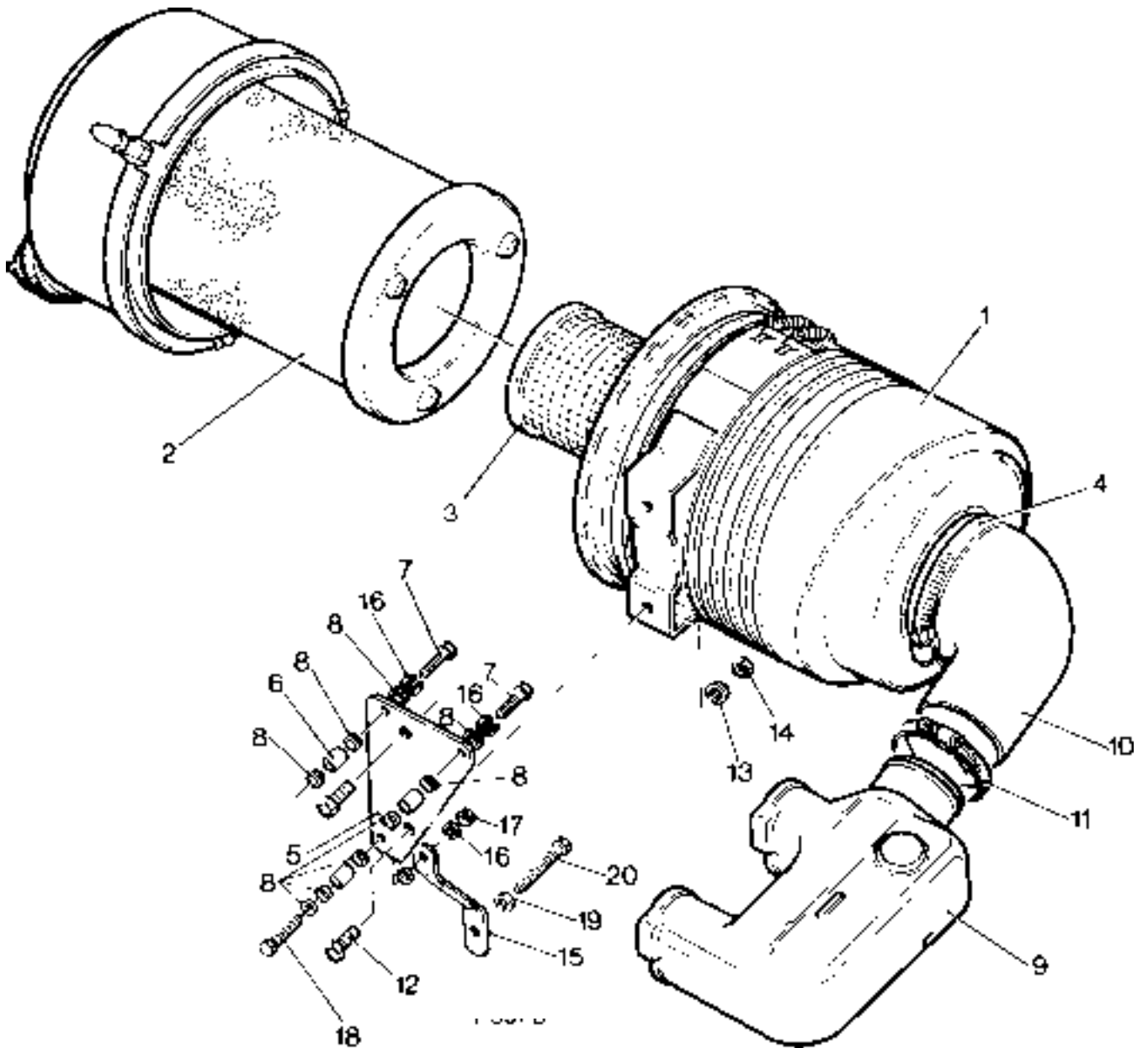

7" Front Remote Mounted Cyclonic Air Cleaner - TS/TR2,3

Illustration T398

No. Description

Part Number

TS/TR

1 2 3 Remarks

	Accessory Kit Code AG - TS/TR2,3.....	570-41670	-	1	1	
1	Air Cleaner Assembly	366-08108	-	1	1	See Note:
2	Main Element	366-08109	-	1	1	
3	Safety Element	366-08110	-	1	1	
4	Sleeve	366-08094	-	1	1	
5	Air Inlet Hose	366-08098	-	1	1	
6	Hose Clip	027-04234	-	3	3	
7	Spigot	366-07657	-	1	1	
8	Air Hose	366-06986	-	1	1	
9	Hose Clip	027-04696	-	1	1	
-	Setscrew - M8 x 20mm	272-00039	-	2	2	
-	Nut.....	272-00003	-	2	2	
-	Spring Washer.....	272-00071	-	2	2	

Note:

Replaces 366-07280 (TR3 up to 2500r/min)
and 382-04369 (TR3 above 2500r/min)

Illustration T398

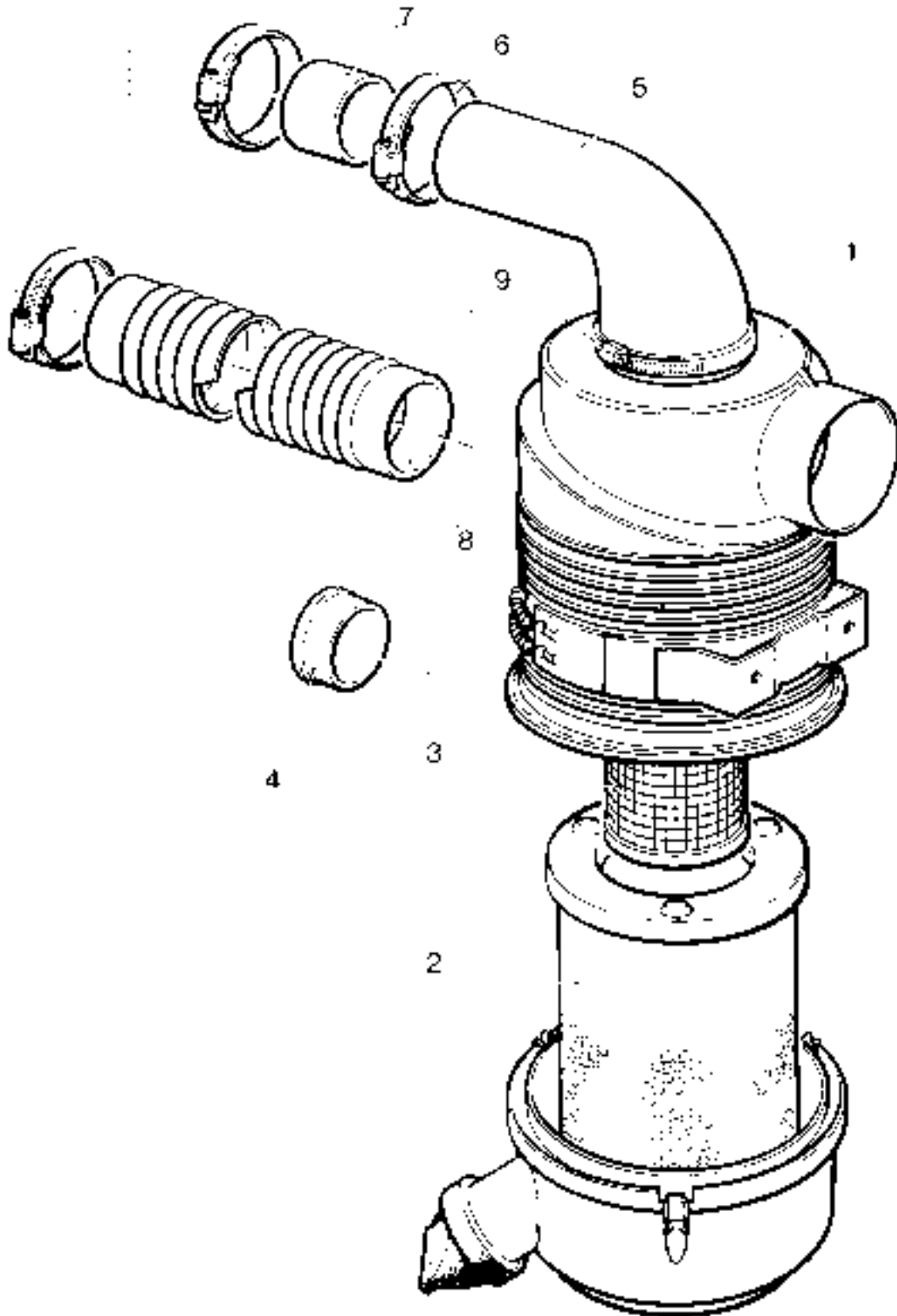

Heavy Duty Oil Bath Air Cleaner - TS/TR1

Illustration T400
No. Description

Part Number TS/TR
1 2 3 Remarks

No.	Description	Part Number	TS	TR	Remarks
	Accessory Kit Code AN	570-33880	1	-	-
1	Oil Bath Air Cleaner	201-42700	1	-	-
2	Inlet/Exhaust Manifold	201-42670	1	-	-
3	Joint.....	201-33420	1	-	-
4	Stud - M8 x 90mm	272-00602	1	-	-
5	Stud - M6 x 30mm	272-00304	1	-	-
6	Joint.....	201-42680	2	-	One each side of air cowling
7	Setscrew - M8 x 20mm	272-00039	2	-	-
8	Spring Washer	272-00071	2	-	-
9	Washer	204-53470	1	-	-
10	Air Cleaner Stay	201-42690	1	-	-
11	Spring Washer	027-00984	1	-	-
12	Setscrew - 7/16"UNC x 7/8"	270-00350	1	-	-
13	Setscrew - M6 x 16mm	272-00034	1	-	-
14	Spring Washer	272-00070	1	-	-
15	Nut.....	272-00002	1	-	-

Illustration T400

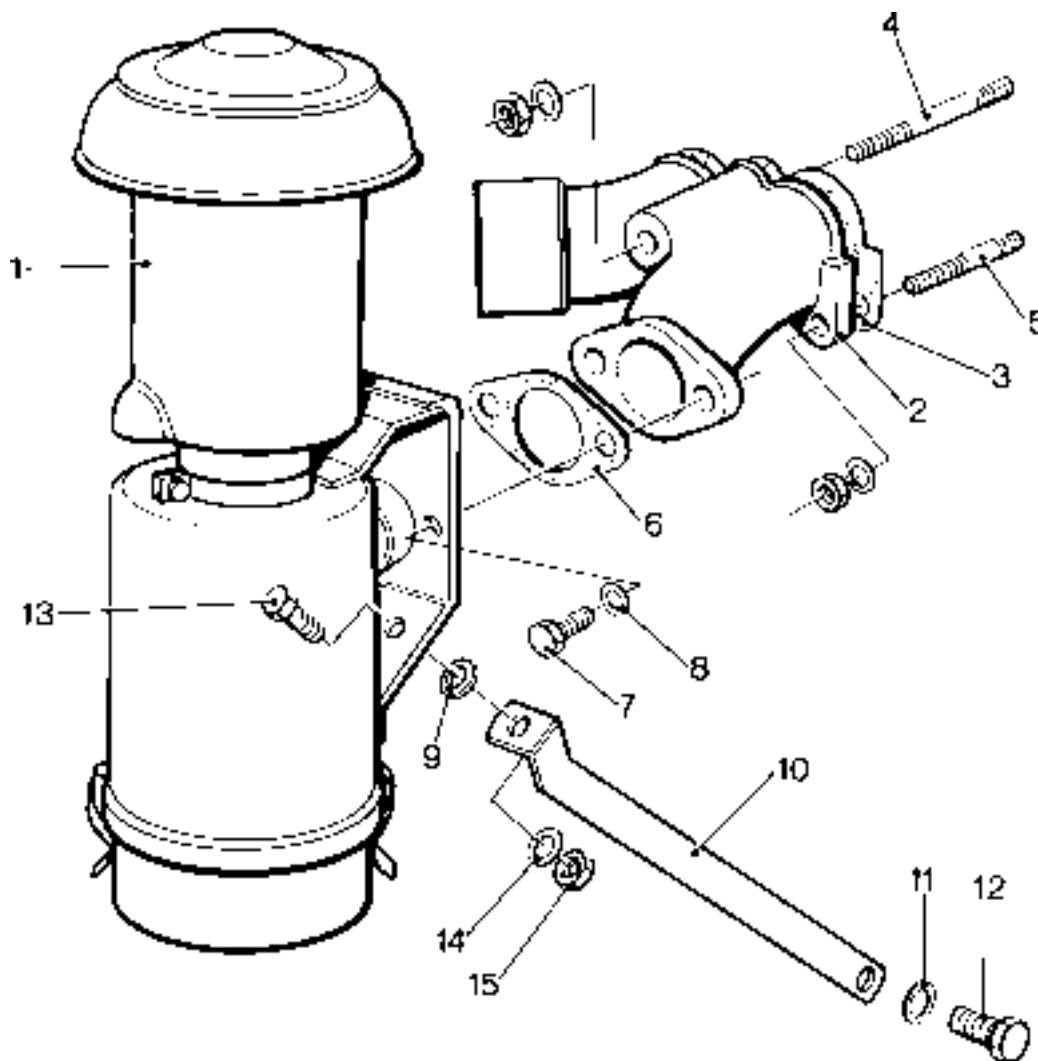

Medium Duty Oil Bath Air Cleaner

Illustration T162
No. Description

TS/TR
Part Number 1 2 3 Remarks

	Accessory Kit Code AK - TS/TR1	570-32770	1	-	-	Use with code AS
	Accessory Kit Code AR - TS/TR2	570-36901	-	1	-	
	Accessory Kit Code AR - TS/TR3	570-36902	-	-	1	TR3 up to 2000 r/min
1	Oil Bath Air Cleaner	203-11422	1	1	1	
2	Hose Clip	027-04234	2	2	2	
3	Bush	201-55530	1	1	1	
4	Sleeve	201-54980	1	1	1	

Note:

On the TS/TR2 Accessory Kit Code AR also includes:
Air Inlet Manifold (202-45880) and Manifold Joint (201-33420)

On the TS/TR3 Accessory Kit Code AR also includes:
Air Inlet Manifold (203-45880) and Manifold Joint (201-33420)

Illustration T162

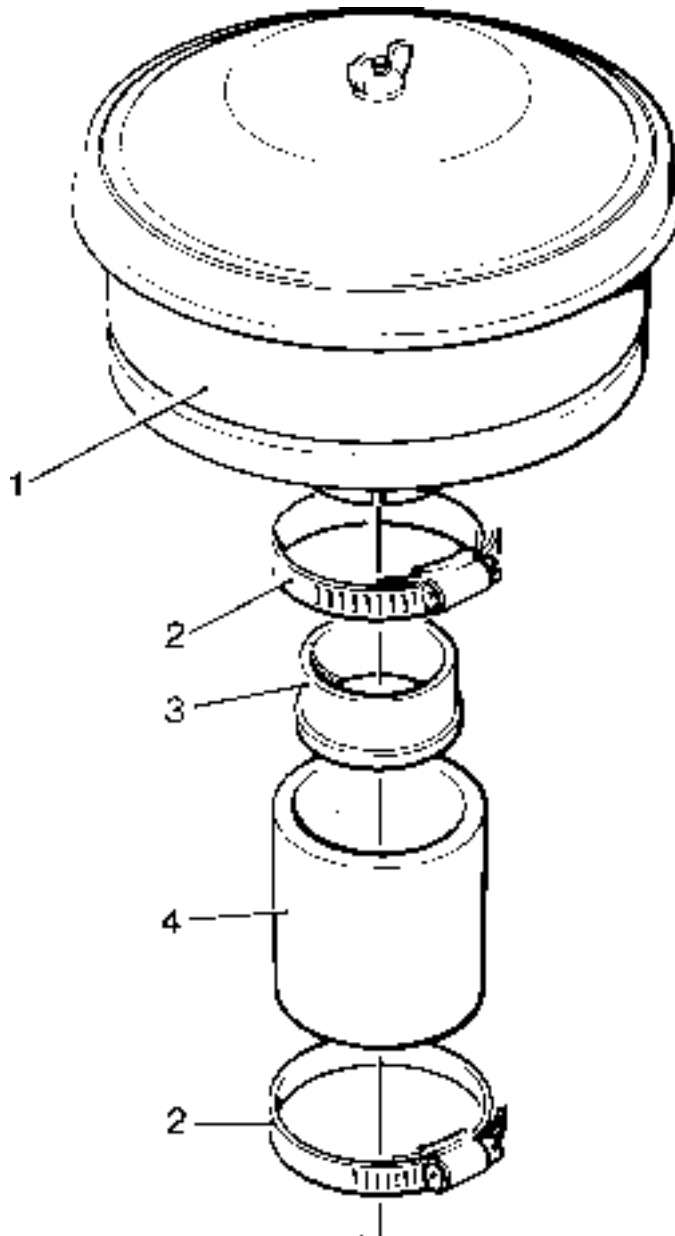

Power Take-Off

8" Newage SAE5

Illustration T120

No. Description

Part Number	TS/TR			Remarks
	1	2	3	

1	Clutch Drive Member	202-35210	-	1	1	
2	Bolt - M12 x 80	272-00368	-	3	3	
3	Spring Washer	272-00073	-	3	3	
4	Bolt - M8 x 30	272-00041	-	4	4	
5	Spring Washer	272-00071	-	4	4	
6	Dowel	351-13660	-	1	1	
7	SAE4 - SAE5 Adaptor	202-35200	-	1	1	
8	Adaptor Guard	202-34972	-	1	1	
9	Clamping Bracket	601-38441	-	2	2	
10	Bolt - M6 x 50mm	272-00180	-	2	2	
11	Washer	027-00618	-	2	2	
12	Self-locking Nut	272-00024	-	2	2	
13	Bolt - ³ / ₈ "UNC x ² / ₄ "	270-00780	-	12	12	
14	Spring Washer	027-00393	-	12	12	
15	Washer	027-00184	-	12	12	
16	Setscrew - ³ / ₈ "UNC x 1 ¹ / ₈ "	270-00485	-	8	8	
17	Spring Washer	027-00393	-	8	8	
18	Power Take-off Assembly	366-06978	-	1	1	
19	Clutch Drive Plate	366-06984	-	1	1	
20	Friction Plate	661-10720	-	1	1	
21	Pressure Plate	366-06983	-	1	1	
22	Setscrew - ⁵ / ₁₆ "UNF x ³ / ₄ "	270-00060	-	6	6	
23	Spring Washer	027-00413	-	6	6	
24	Bearing Release	366-06980	-	1	1	
25	Bearing Retainer	366-07000	-	1	1	

Illustration T120

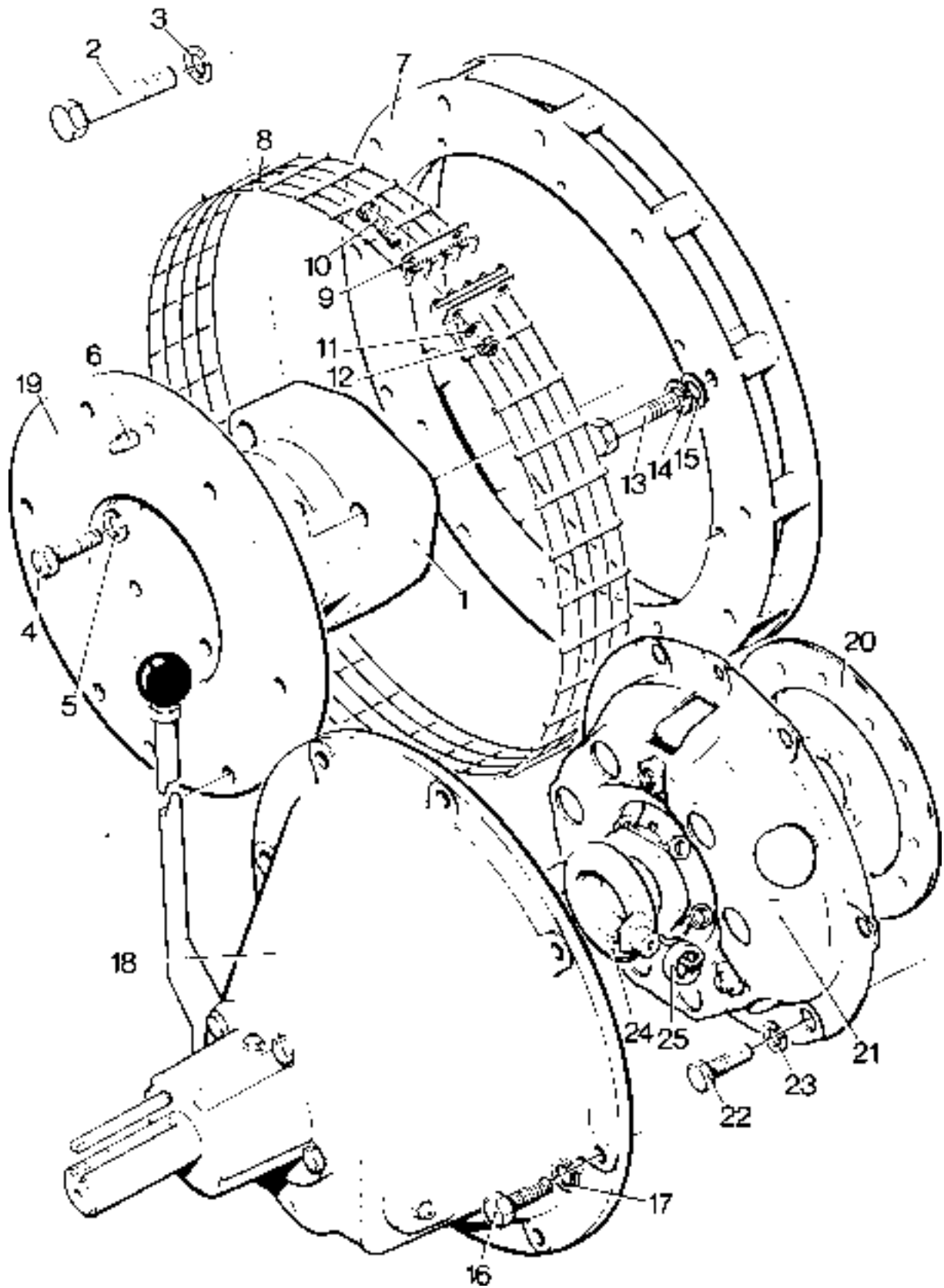

Overcentre Clutch

Illustration T422 No.	Description	Part Number	TS/TR			Remarks
			1	2	3	
	Accessory Kit Code BE	570-31480	1	1	1	
1	7 ¹ / ₂ " Overcentre Clutch	202-35630	1	1	1	
2	Bolt - ³ / ₈ "UNC x 3 ¹ / ₄ "	755060	12	12	12	Replaces 270-00373
3	Spring Washer	027-00393	12	12	12	
4	Setscrew - ⁵ / ₁₆ "UNC x 1"	270-00263	8	8	8	
5	Spring Washer	272-00071	8	8	8	
6	Bearing	366-06997	1	1	1	
7	Guard	202-34972	1	1	1	
8	Clamping Bracket	601-38441	2	2	2	
9	Bolt - M6 x 50mm	272-00180	2	2	2	
10	Washer	027-00618	2	2	2	
11	Self Locking Nut	272-00372	2	2	2	
12	SAE4 Adaptor	202-31852	1	1	1	
13	Drive Member	202-34980	1	1	1	See Note
14	Bolt - M12 x 80mm	272-00368	3	3	3	
15	Spring Washer	272-00073	3	3	3	
16	Clutch Friction Disc	660-13940	1	1	1	
17	Case Bearing	660-14010	1	1	1	

Note:

Drive member Accessory Kit available under code CL (570-31650)
consisting of no's 4, 5, 6, 13, 14, 15

Illustration T422

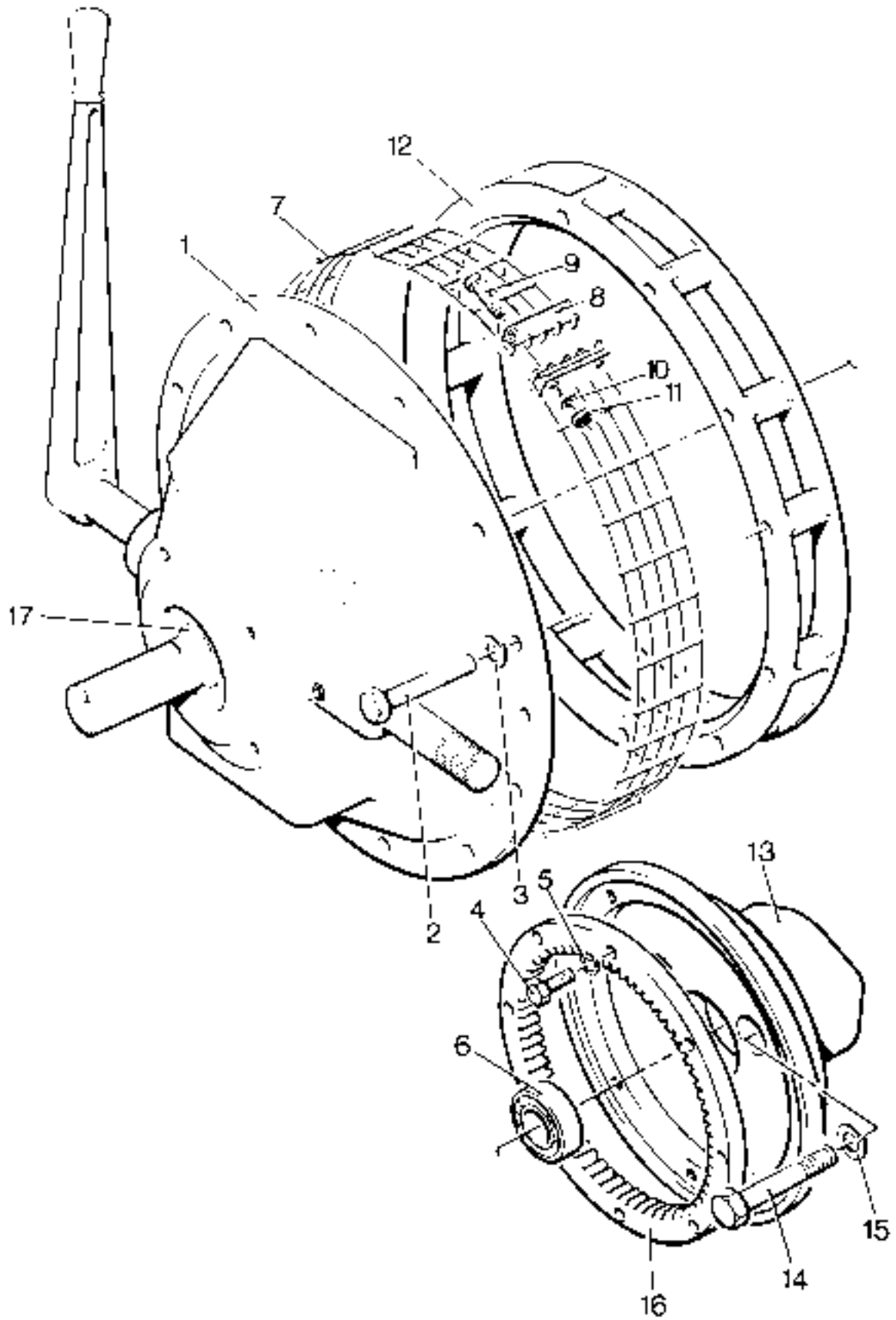

Flat Belt Pulley - TS/TR1 and TS3

Not Illustrated Description	Part Number	TS/TR			Remarks
		1	2	3	
Accessory Kit Code BN - TS/TR1	570-32950	1	-	-	
Pulley	201-41730	1	-	-	
Bolt - M12 x 50mm	272-00254	3	-	-	
Spring Washer	272-00073	3	-	-	
Accessory Kit Code BF - TS3	570-37460	-	-	1	
Pulley	201-47510	-	-	1	
Flat Belt - 100mm x 6m	201-47520	-	-	1	
Key	201-47530	-	-	1	

SAE Adaptor and Guard

Illustration T55 No. Description	Part Number	TS/TR			Remarks
		1	2	3	
Accessory Kit Code CA	570-31590	1	1	1	For Adaptor SAE4/5
Accessory Kit Code CB	570-31600	1	1	1	For Adaptor SAE4
1 Adaptor SAE4/5	202-35200	1	1	1	51mm wide
- Adaptor SAE4	202-31852	1	1	1	51mm wide
2 Guard	202-34972	1	1	1	Replaces 202-34970
3 Clamping Bracket	601-38441	2	2	2	Required with 202-34970
4 Bolt - M6 x 50mm	272-00180	2	2	2	
5 Washer	027-00618	2	2	2	
6 Self-locking Nut	272-00372	2	2	2	
7 Bolt - 3/8"UNC x 2 3/4"	270-00780	12	12	12	
8 Spring Washer	270-00393	12	12	12	
9 Washer	027-00184	12	12	12	

Illustration T55

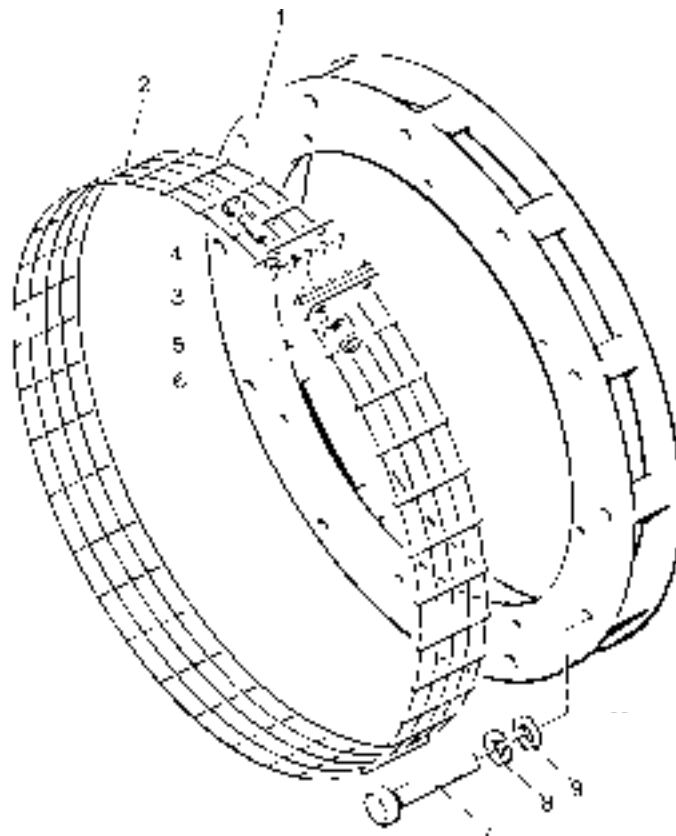

Fenner Coupling

Illustration T200

No.	Description	Part Number	TS/TR			Remarks
			1	2	3	
	Accessory Kit Code BO	570-31520	1	1	1	Comprising no's 1(a) & 2-6
	Accessory Kit Code BQ	570-31540	1	1	1	For 35mm shaft Comprising no's 1(a), 2-6 & 7(b)
	Accessory Kit Code BL	601-53920	1	1	1	For 35mm shaft Comprising no's 1(c), 2-6
	Accessory Kit Code BR	570-31550	1	1	1	For 38mm shaft Comprising no's 1(a), 2-6 & 7(c)
	Accessory Kit Code BS	570-31560	1	1	1	For 42mm shaft Comprising no's 1(a), 2-6 & 7(d)
	Accessory Kit Code BX	570-31521	1	1	1	Comprising no's 1(b) & 2-6
1	(a) Coupling Assembly	202-35300	1	1	1	With taper lock
-	(b) Coupling Assembly	202-46160	1	1	1	'B' flange 110mm
-	(c) Coupling Assembly	601-53940	1	1	1	Solid Boss
2	Flywheel Coupling Flange	202-35310	1	1	1	
3	Element	202-35320	1	1	1	Standard element. Included in Coupling Assemblies (a) & (c)
-	Element	601-42090	1	1	1	Harder element. Included in Coupling Assembly (b)
4	Flange	202-35330	1	1	1	Included in Coupling Assemblies (a) & (b)
-	'B' Flange - Pilot bored	601-42100	1	1	1	Included in Coupling Assembly (c)
5	Setscrew - M12 x 35mm	272-00240	3	3	3	
6	Spring Washer	272-00073	3	3	3	
7	(a) Taper Lock Bush - 32mm	202-35340	1	1	1	
-	(b) Taper Lock Bush - 35mm	202-35341	1	1	1	
-	(c) Taper Lock Bush - 38mm	202-35344	1	1	1	
-	(d) Taper Lock Bush - 42mm	202-35343	1	1	1	

Illustration T200

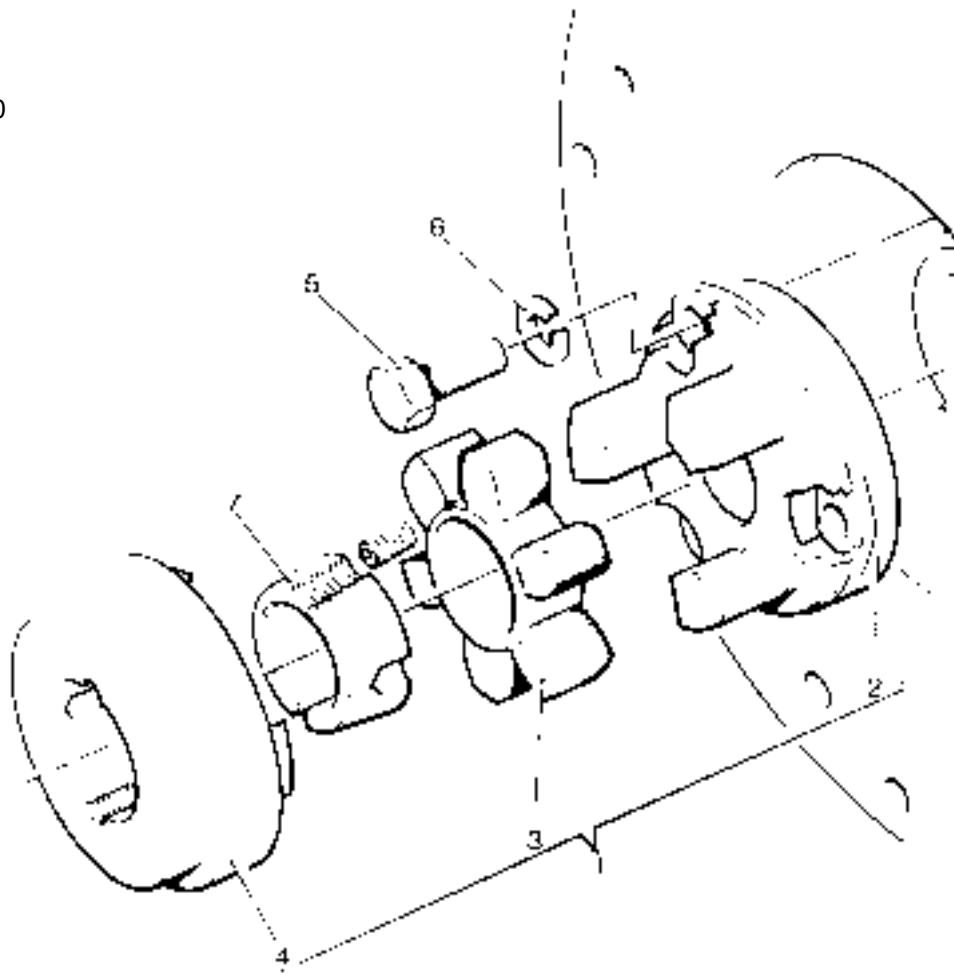

Automotive Clutch Drive Member

Illustration T59 No. Description	Part Number	TS/TR			Remarks
		1	2	3	
Accessory Kit Code CH	570-31630	1	1	1	For 8" Drive Member Use with adaptor code CA or CB
Accessory Kit Code CI	570-31640	1	1	1	For 9" Drive Member Use with adaptor code CA or CB
1 Drive Member - 8"	202-35210	-	1	1	
- Drive Member - 9"	202-35211	1	1	1	
2 Bolt - M12 x 80mm	272-00368	3	3	3	
3 Spring Washer	272-00073	3	3	3	
4 Bolt - M8 x 30mm	272-00041	4	4	4	
5 Spring Washer	272-00071	4	4	4	
6 Dowel	351-13660	1	1	1	

Illustration T59

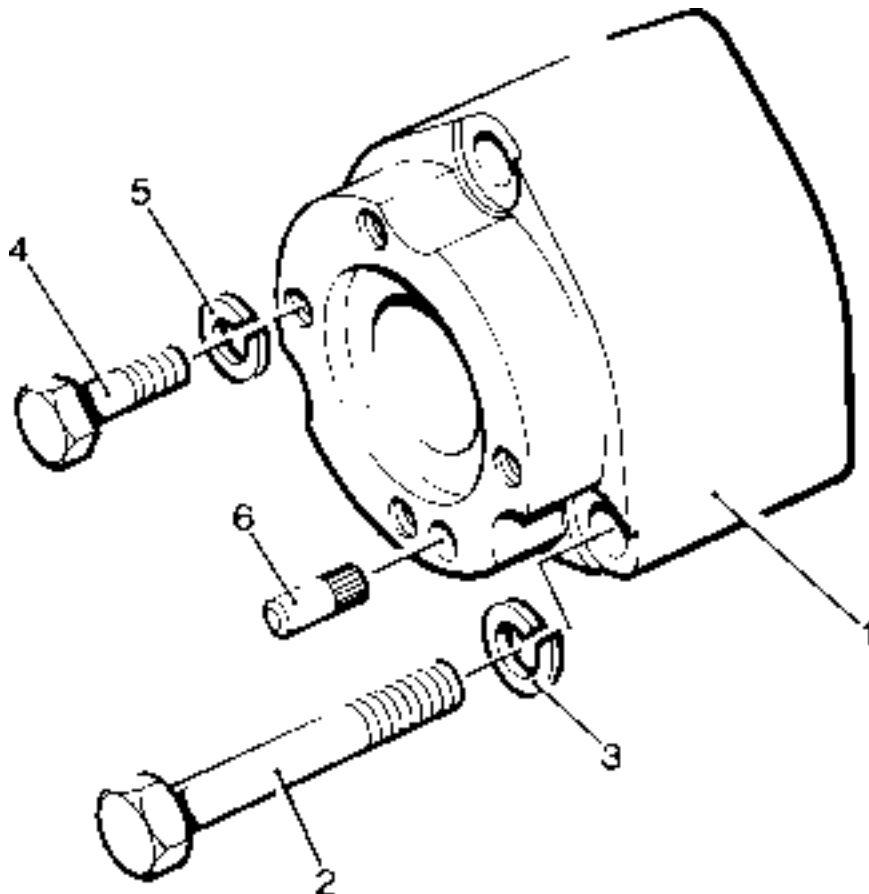

Flexible Coupling - TR2

Illustration T339
No. Description

TS/TR
Part Number 1 2 3 Remarks

No.	Description	Part Number	1	2	3	Remarks
1	Centamex Coupling - Pilot Bored	202-44880	-	1	-	
2	Bolt - M12 x 50mm	272-00254	-	3	-	
3	Spring Washer.....	272-00073	-	3	-	

Illustration T339

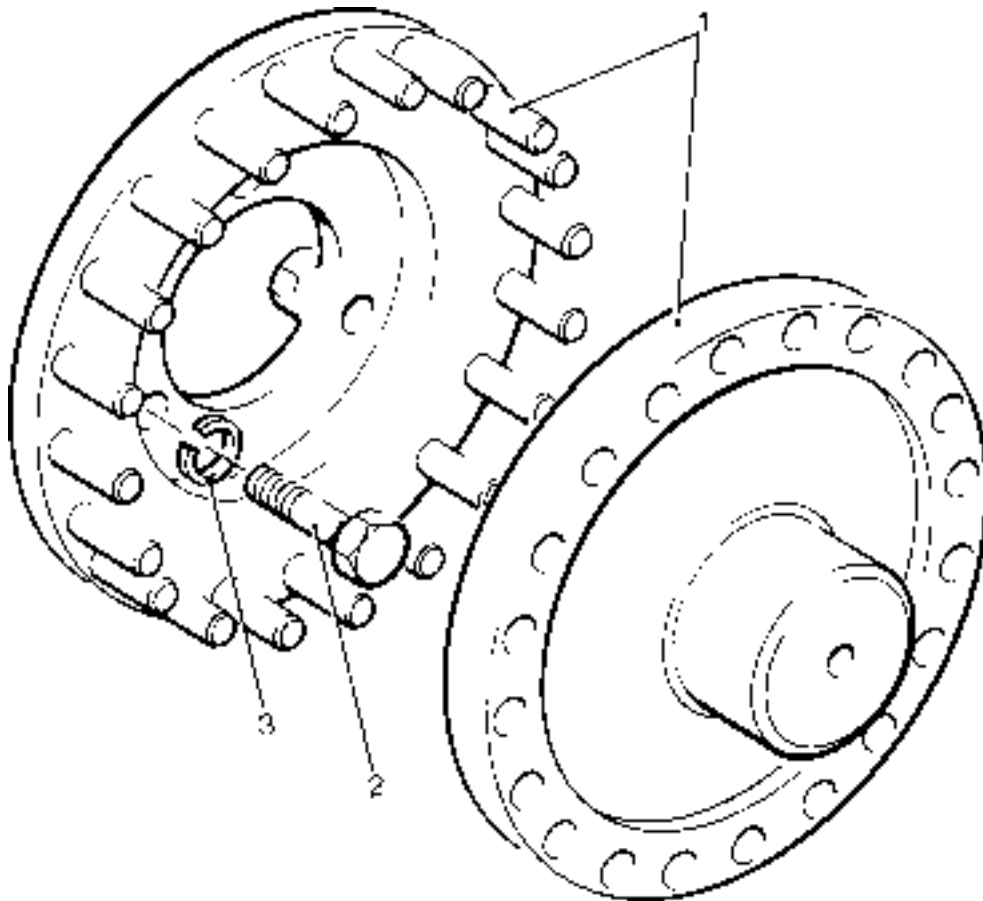

Extra Flexible Coupling - TR2

Illustration T418
No. Description

TS/TR
Part Number 1 2 3 Remarks

	Accessory Kit Code CY	570-34670	-	1	-	
1	Centamex Coupling - Pilot Bored	202-44890	-	1	-	
2	Bolt - M12 x 50mm	272-00254	-	3	-	
3	Spring Washer	272-00073	-	3	-	

Note:
Suitable for TR2 1500 r/min generating sets for 35mm shaft.

Illustration T418

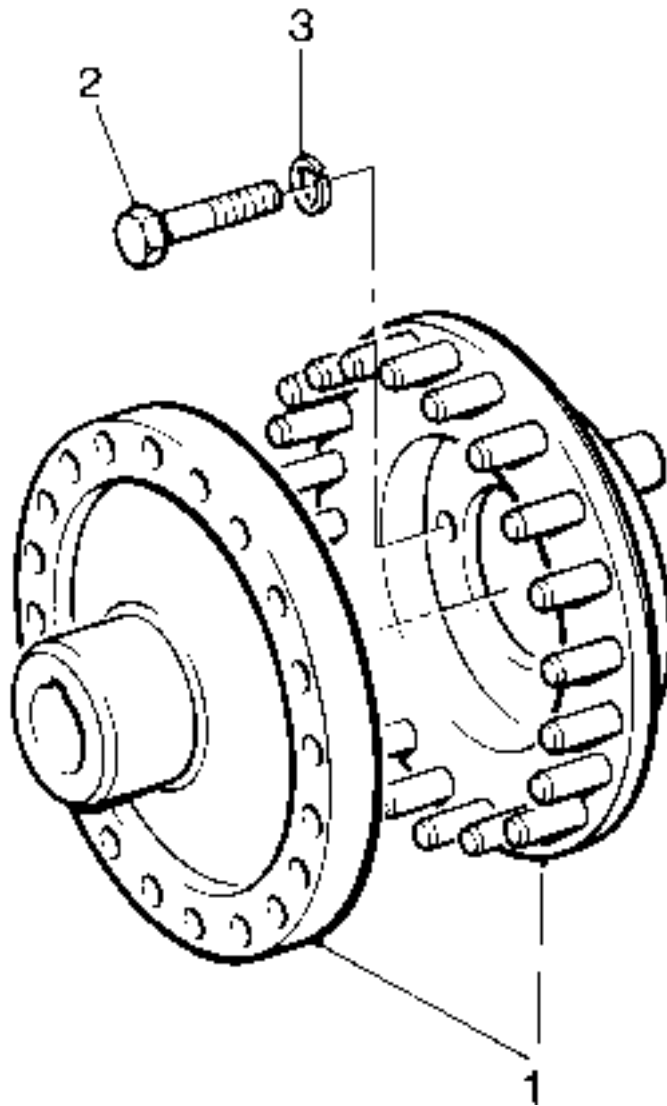

Hydraulic Pump Adaptor - TS2,3

Not Illustrated Description	Part Number	TS/TR			Remarks
		1	2	3	
Accessory Kit Code HN	570-35750	-	1	1	
Adaptor	202-44306	-	1	1	
Bolt	755686	-	3	3	
Copper Washer	201-11890	-	4	4	
Stud	270-01077	-	1	1	
Nut	270-00005	-	1	1	
Bolt	272-00191	-	4	4	
Spring Washer	272-00070	-	4	4	
Coupling Assembly	757-13252	-	1	1	
Bolt	272-00116	-	3	3	

Hydraulic Pump Adaptor - Gear End

4 bolt pump flange

Illustration T77

No.	Description	Part Number	TS/TR			Remarks
			1	2	3	
	Accessory Kit Code HF - TS/TR1	570-41530	1	-	-	
	Accessory Kit Code HF - TS/TR2,3	570-41540	-	1	1	
-	Pump Gear Assembly	570-30293	1	1	1	See Note
1	Pump Gear		1	1	1	
2	Adaptor Plate - TS/TR1	366-08065	1	-	-	Replaces 201-38130
-	Adaptor Plate - TS/TR2,3	366-08063	-	1	1	Replaces 366-04139
3	'O' Ring	366-08066	1	1	1	Replaces 201-41381 (TS/TR1) and 366-07427 (TS/TR2,3)
4	Pump to Adaptor Plate Joint	366-07428	1	1	1	
5	Stud - 1/4"UNF x 1 ³ / ₈ " Pump to Adaptor	270-00606	4	4	4	
6	Spring Washer	027-00451	4	4	4	
7	Nut.....	270-00002	4	4	4	
8	Bolt - M8 x 35mm	272-00042	3	3	3	Replaces 272-00040 (TS/TR1) and 272-00041 (TS/TR2,3)
9	Stud - M8 x 35mm	272-00266	1	1	1	
10	Spring Washer	272-00071	4	4	4	
11	Nut.....	272-00003	4	4	4	

Note:

Comprises Pump Gear (201-31913) and Drive Pinion (201-31903). It is recommended that these items be fitted as a matched pair.

Illustration T77

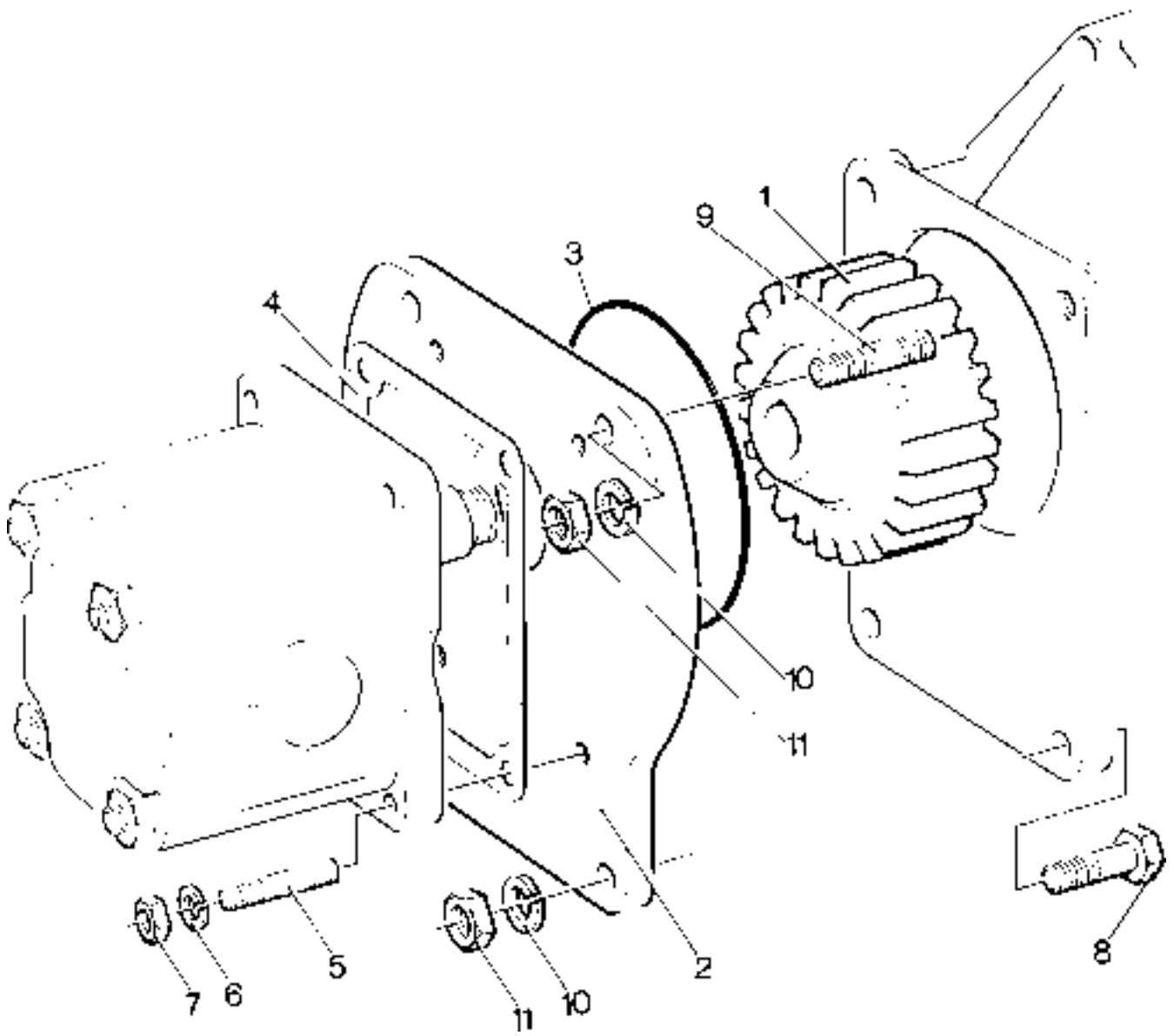

Hydraulic Pump Adaptor - Gear End

2 bolt pump flange

Illustration T319

No.	Description	Part Number	TS/TR			Remarks
			1	2	3	
	Accessory Kit Code HI	570-41550	1	1	1	SAEA hydraulic pump 15 bhp limit
-	Pump Gear Assembly	570-30293	1	1	1	See Note:
1	Pump Gear		1	1	1	
2	Adaptor Plate	366-08064	1	1	1	Replaces 366-07217
3	'O' Ring	366-08066	1	1	1	Replaces 201-41381
4	Pump to Adaptor Plate Joint	201-32941	1	1	1	
5	Bolt - M8 x 35mm	272-00042	3	3	3	Replaces 272-00041
6	Stud - M8 x 35mm	272-00266	1	1	1	
7	Spring Washer	272-00071	4	4	4	
8	Nut	272-00003	4	4	4	
9	Stud	366-07747	2	2	2	
10	Spring Washer	027-00393	2	2	2	
11	Nut	270-00004	2	2	2	

Note:

Comprises Pump Gear (201-31913) and Drive Pinion (201-31903). It is recommended that these items be fitted as a matched pair.

Illustration T319

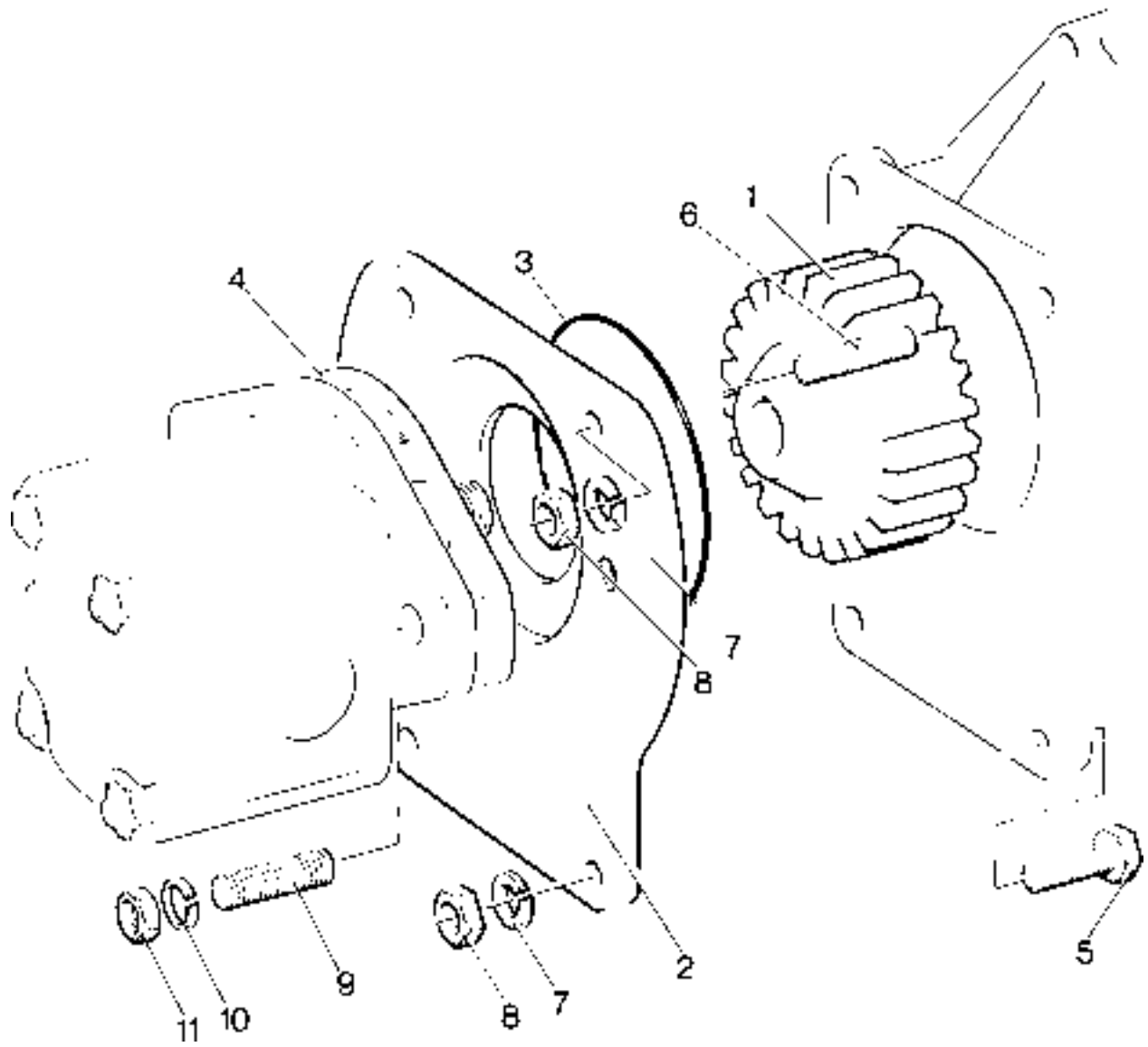

Hydraulic Pump Adaptor - Flywheel End

4 bolt pump flange

Illustration T122

No. Description

Part Number TS/TR
1 2 3 Remarks

No.	Description	Part Number	1	2	3	Remarks
	Accessory Kit Code HH	570-31830	1	1	1	For 1P3000 pump (or equivalent)
	Accessory Kit Code HK	570-31850	1	1	1	For 2P3000 pump (or equivalent)
1	Adaptor - 1P3000	202-35282	1	1	1	
-	Adaptor - 2P3000	202-35284	1	1	1	
2	Bolt	270-00759	12	12	12	
3	Spring Washer	027-00393	12	12	12	
4	Washer	027-00184	12	12	12	
5	Drive Member	202-35361	1	1	1	Replaces 202-35360 See Note:
6	Bolt - M12 x 50mm	272-00254	3	3	3	
7	Spring Washer	272-00073	3	3	3	
8	Coupling - 1P3000	757-13252	1	1	1	Replaces 601-40110 See Note:
-	Coupling - 2P3000	757-13250	1	1	1	Replaces 601-40120 See Note:
-	Coupling - Pilot Bored	757-13251	1	1	1	Replaces 202-35390 See Note:
9	Bolt - M10 x 45mm	272-00213	3	3	3	
10	Bolt - 1P3000 M6 x 35mm	272-00191	4	4	4	
11	Spring Washer	272-00070	4	4	4	
-	Bolt - 2P3000 M6 x 40mm	272-00043	4	4	4	
-	Spring Washer	272-00071	4	4	4	
12	Rim Guard	202-34972	1	1	1	
13	Clamping Bracket	601-38441	2	2	2	
14	Setscrew	272-00180	2	2	2	
15	Washer	027-00618	2	2	2	
16	Self-locknut	272-00372	2	2	2	
17	Face Guard	366-08033	1	1	1	

Note:

The later couplings can only be used with Drive Member 201-35361

Illustration T122

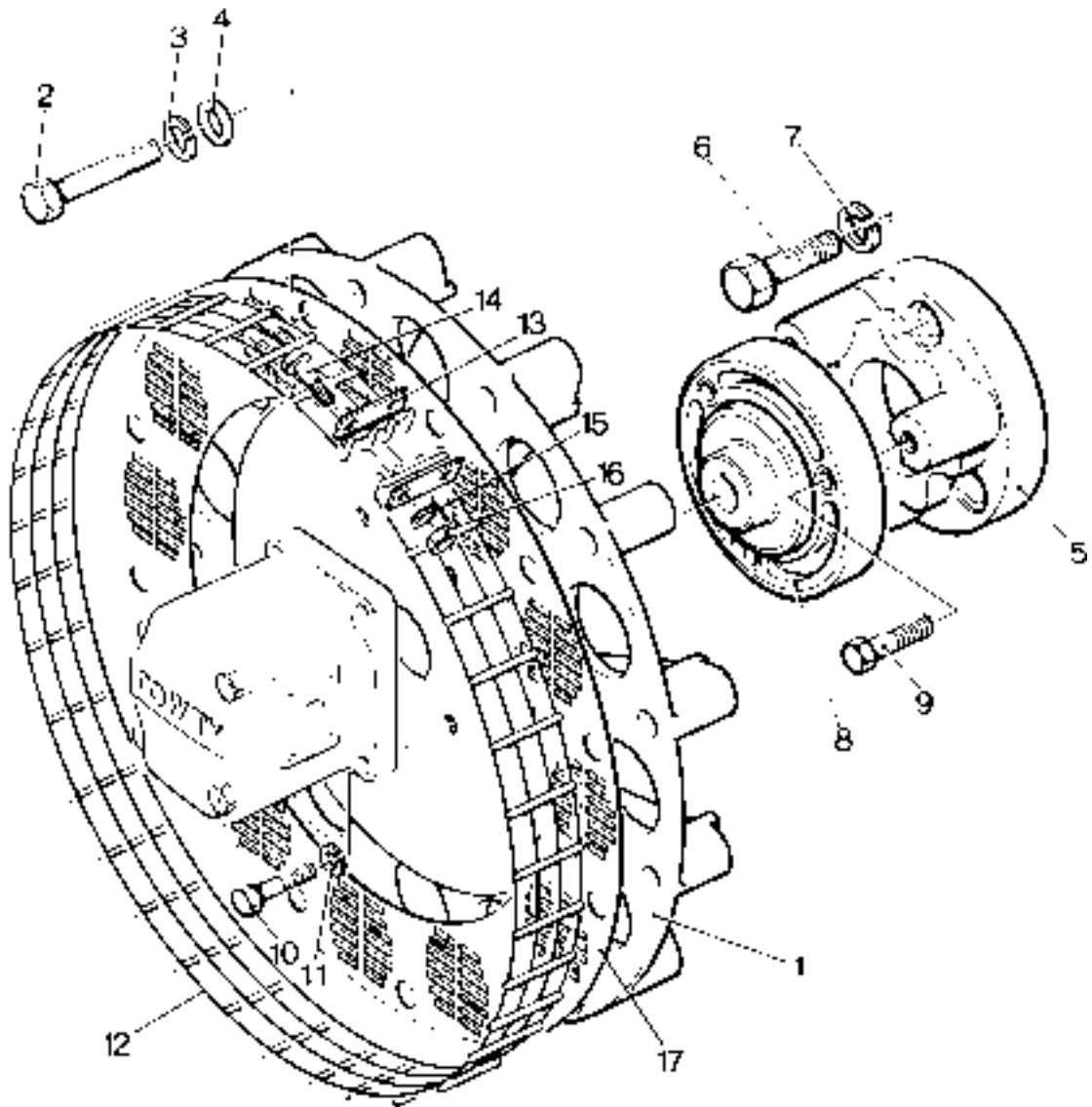

Hydraulic Pump Adaptor - Flywheel End

2 bolt pump flange

Illustration T373

No.	Description	Part Number	TS/TR			Remarks
			1	2	3	
	Former Accessory Kit Code HJ	570-34130	1	1	1	Replaces 570-31840
	Former Accessory Kit Code HL	570-34140	1	1	1	Replaces 570-31860
1	Adaptor - 1P3000	202-35281	1	1	1	Code HJ
-	Adaptor - 2P3000	202-35283	1	1	1	Code HL
2	Bolt ³ / ₈ "UNC x 2 ¹ / ₄ "	270-00759	12	12	12	
3	Spring Washer	027-00393	12	12	12	
4	Washer	027-00184	12	12	12	
5	Drive Member	202-35361	1	1	1	Replaces 202-35360
6	Bolt - M12 x 50mm	272-00254	3	3	3	
7	Spring Washer	272-00073	3	3	3	
8	Coupling - 1P3000	202-43220	1	1	1	Code HL
-	Coupling - 2P3000	202-43210	1	1	1	Code HJ
9	Setscrew - 1P3000 M10 x 30mm	272-00080	2	2	2	
10	Spring Washer	272-00072	2	2	2	
-	Setscrew - 2P3000 M12 x 35mm	272-00240	2	2	2	
-	Spring Washer	272-00073	2	2	2	
11	Rim Guard	202-34972	1	1	1	
12	Clamping Bracket	601-38441	2	2	2	
13	Setscrew	272-00180	2	2	2	
14	Washer	027-00618	2	2	2	
15	Self-locknut	272-00372	2	2	2	
16	Adapter Plate Guard	366-08033	1	1	1	

Illustration T373

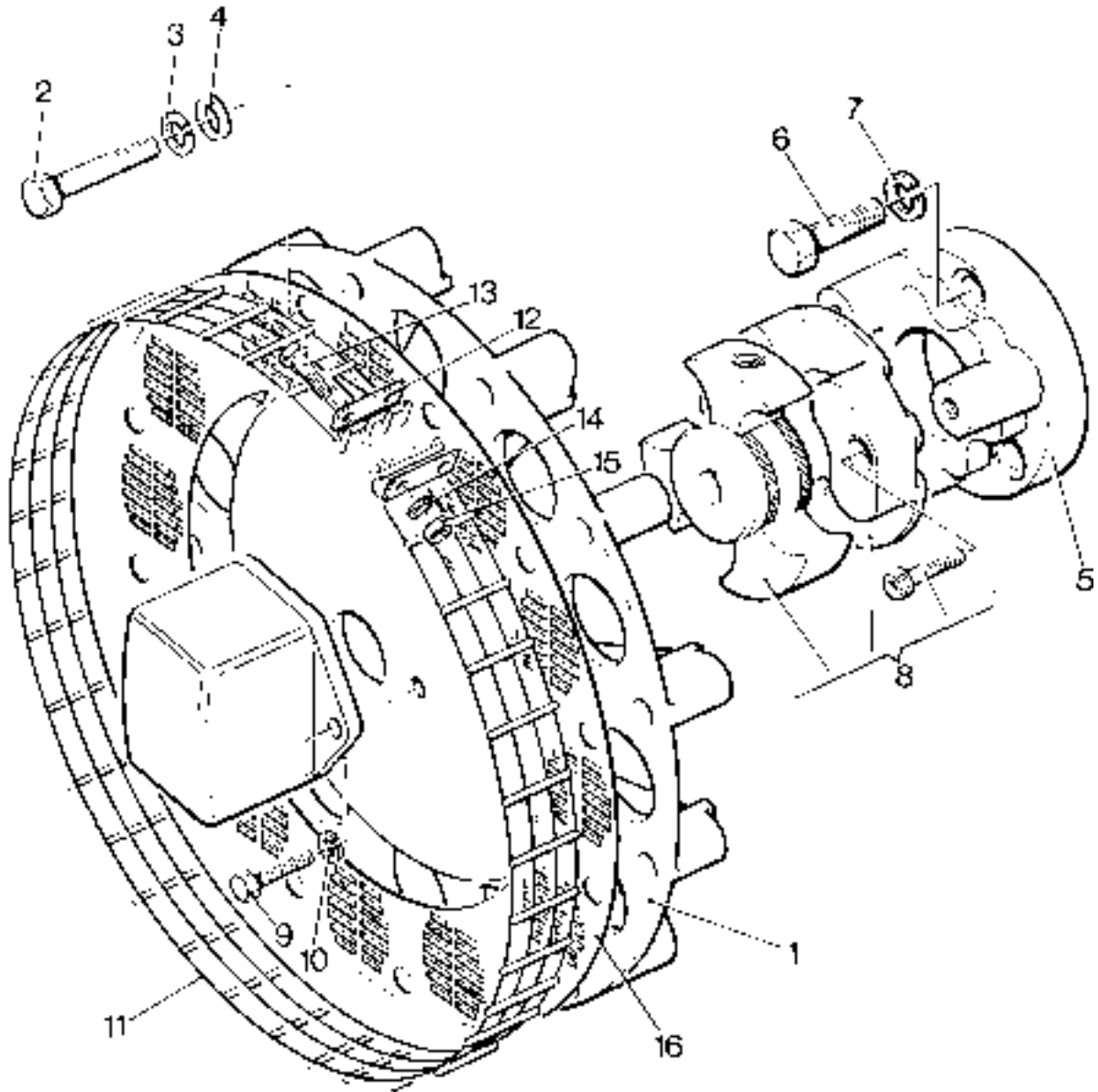

Electric Start Panel - 12V

For use with the Synchro charging system

Illustration T193A

No.	Description	Part Number	TS/TR			Remarks
			1	2	3	
	Accessory Kit Code WM	602-51752	1	1	1	
-	Start Control Panel Assembly	570-33701	1	1	1	
1	Panel	607-10036	1	1	1	Replaces 607-10016
-	Impulse Transmitter Assembly	607-10035	1	1	1	Replaces 366-07229
2	Impulse Transmitter	602-36870	1	1	1	
3	Push-on Connector	064-33068/001	1	1	1	
4	Push-on Connector	064-33068/002	1	1	1	
-	Push-on Connector	064-33380/002	1	1	1	
5	Insulation Cover	064-33991/001	3	3	3	
6	Screw	064-06772/002	1	1	1	
7	Spring Washer	064-02582/002	1	1	1	
8	Nut	064-06611/003	1	1	1	
9	Screw	064-06617/012	1	1	1	
10	Spring Washer	064-02582/002	1	1	1	
11	Washer	064-06618/004	2	2	2	
12	Nut	064-06614/003	1	1	1	
13	Cable Link Assembly	366-06433	1	1	1	
14	Lamp Holder	366-07228	1	1	1	
15	Lamp	605-00012	1	1	1	
16	Lens	064-20787/001	1	1	1	
17	Key Switch	757-16570	1	1	1	Replaces 366-06379
17a	Key Switch Cover	757-16580	1	1	1	
18	Helvin Button	064-13033/008	1	1	1	
19	Blanking Plug	382-08080	1	1	1	
20	Label	027-07870	1	1	1	Replaces 027-06269
21	Label	027-07871	1	1	1	Replaces 027-06270
22	Back Plate	607-10017	1	1	1	
23	Terminal	064-15648/010	1	1	1	
24	Blade Terminal	366-07230	1	1	1	
25	Cover	366-07231	1	1	1	
26	Push-on Connector	064-33068/002	1	1	1	
-	Terminal	064-33068/003	1	1	1	
27	Cover	064-33991/002	2	2	2	
28	Key	366-08168	1	1	1	
-	Wiring Diagram	742-00589				
-	Wiring Diagram	742-00591				

Illustration T193A

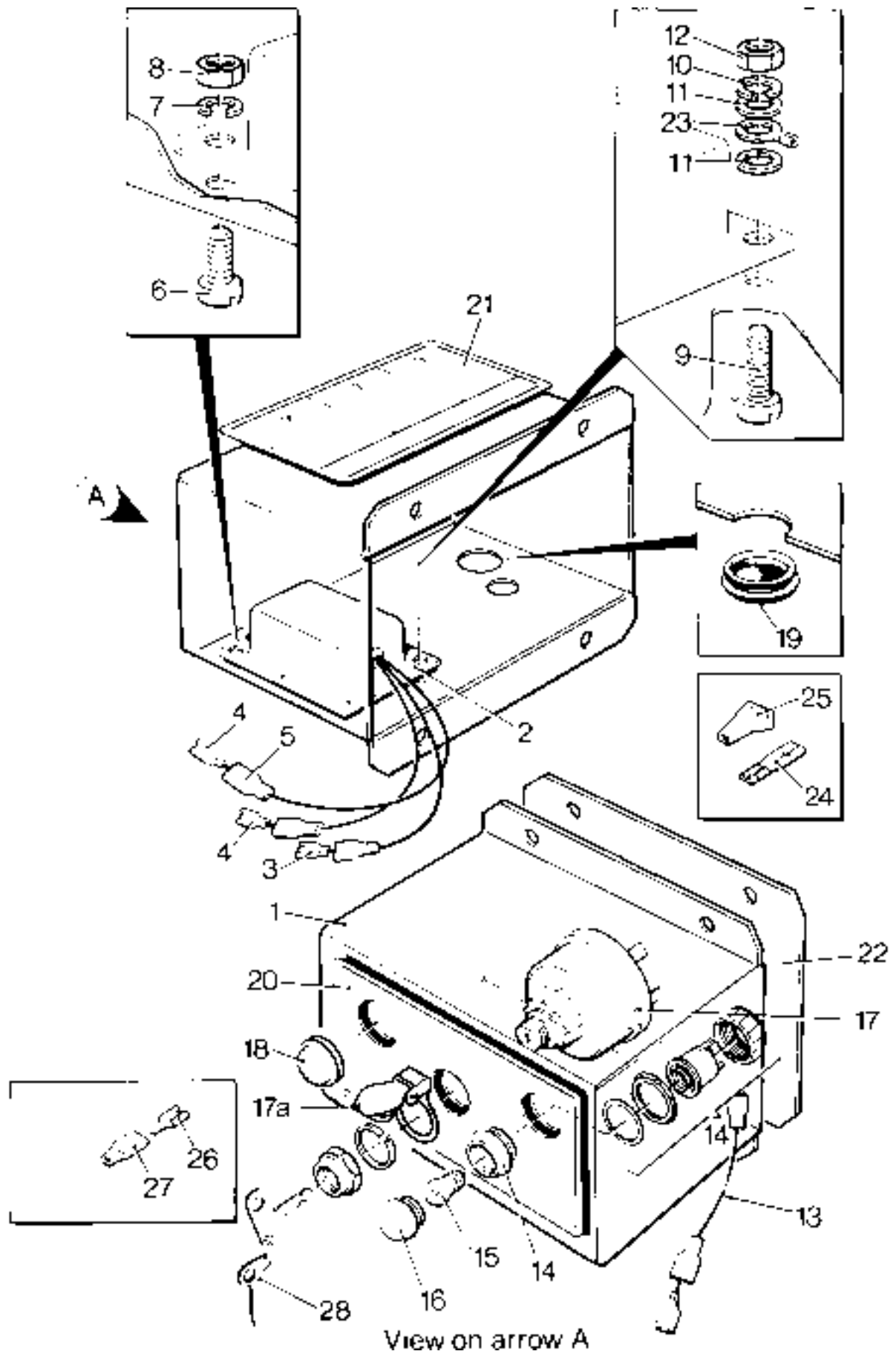

Electric Start Panel - 12V

For use with the Synchro charging system and with provision
for two gauges in the panel

Illustration T188A

No.	Description	Part Number	TS/TR			Remarks
			1	2	3	
1	Panel	366-06937	1	1	1	
2	Impulse Transmitter Assembly	366-07229	1	1	1	
3	Impulse Transmitter	602-36870	1	1	1	
4	Push-on Connector	064-33068/001	1	1	1	
5	Push-on Connector	064-33068/002	2	2	2	
6	Cover	064-33991/001	3	3	3	
7	Screw	064-06772/002	1	1	1	
8	Spring Washer	064-02582/002	1	1	1	
9	Nut	064-06611/003	1	1	1	
10	Screw	064-06617/012	1	1	1	
11	Spring Washer	064-02582/002	1	1	1	
12	Washer	064-06618/004	2	2	2	
13	Nut	064-06611/003	1	1	1	
14	Cable	366-06433	1	1	1	
15	Lamp Holder	366-07228	1	1	1	
16	Lamp	605-00012	1	1	1	
17	Lens	064-20787/001	1	1	1	
18	Key Switch	366-06379	1	1	1	
19	Helvin Button	064-13033/008	1	1	1	
20	Blanking Plug	382-08080	1	1	1	
21	Label	027-06356	1	1	1	
22	Grommet	382-07342	2	2	2	
23	Cable Loom	366-07968	1	1	1	
24	Cable Clip	382-08256	2	2	2	
25	Setscrew - M6 x 12mm	272-00032	2	2	2	
26	Spring Washer	272-00070	2	2	2	
27	Nut	272-00002	1	1	1	
-	Mounting Bracket - TS/TR1	201-42660	1	1	1	
28	Mounting Bracket - TS/TR2,3	202-36442	1	1	1	
29	Flexible Mounting	064-07640	3	3	3	
30	Washer	064-06612/005	6	6	6	
31	Spring Washer	064-02582/002	6	6	6	
32	Nut	064-06610/003	6	6	6	
33	Bolt - M10 x 40mm	272-00116	2	2	2	
34	Spring Washer	272-00072	2	2	2	
35	Spacer	382-07208	2	2	2	
36	Key	366-08168	1	1	1	

Illustration T188A

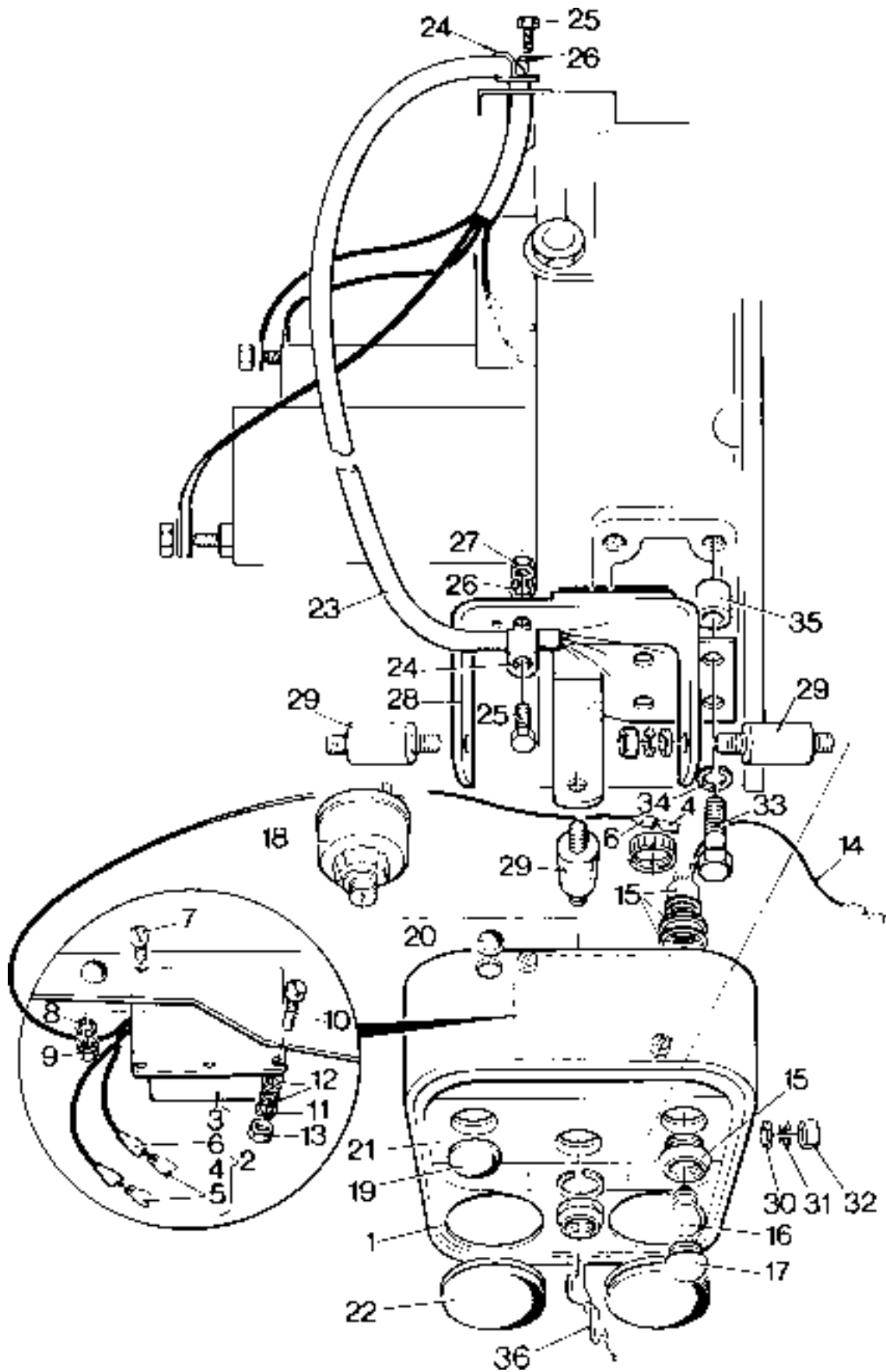

Electric Start Panel - 12V

For use with the Nicsa charging system

Illustration T193B

No.	Description	Part Number	TS/TR			Remarks
			1	2	3	
	Accessory Kit Code WM	570-35441	1	1	1	
-	Control Panel Assembly	570-35401	1	1	1	
1	Panel	607-10016	1	1	1	
2	Cable Link Assembly	366-06433	1	1	1	
3	Lampholder	366-07228	1	1	1	
4	Lamp	064-09681/001	1	1	1	
5	Lens	064-20787/001	1	1	1	
6	Key Switch	366-06379	1	1	1	
7	Helvin Button	064-13033/008	1	1	1	
8	Blanking Plug	382-08080	1	1	1	
9	Label	027-10052	1	1	1	
10	Key	366-08168	1	1	1	
11	Back Plate	607-10017	1	1	1	
12	Push-on Connector	064-33068/001	1	1	1	
13	Push-on Connector	064-33380/001	1	1	1	
14	Insulation Cover	064-33991/001	2	2	2	
15	Push-on Connector	064-33068/002	1	1	1	
16	Cover	064-33991/002	1	1	1	
17	Terminal	064-33068/004	1	1	1	
18	Cover	064-33991/004	1	1	1	
	Wiring Diagram	742-00648				
	Wiring Diagram	742-00796				

Illustration T193B

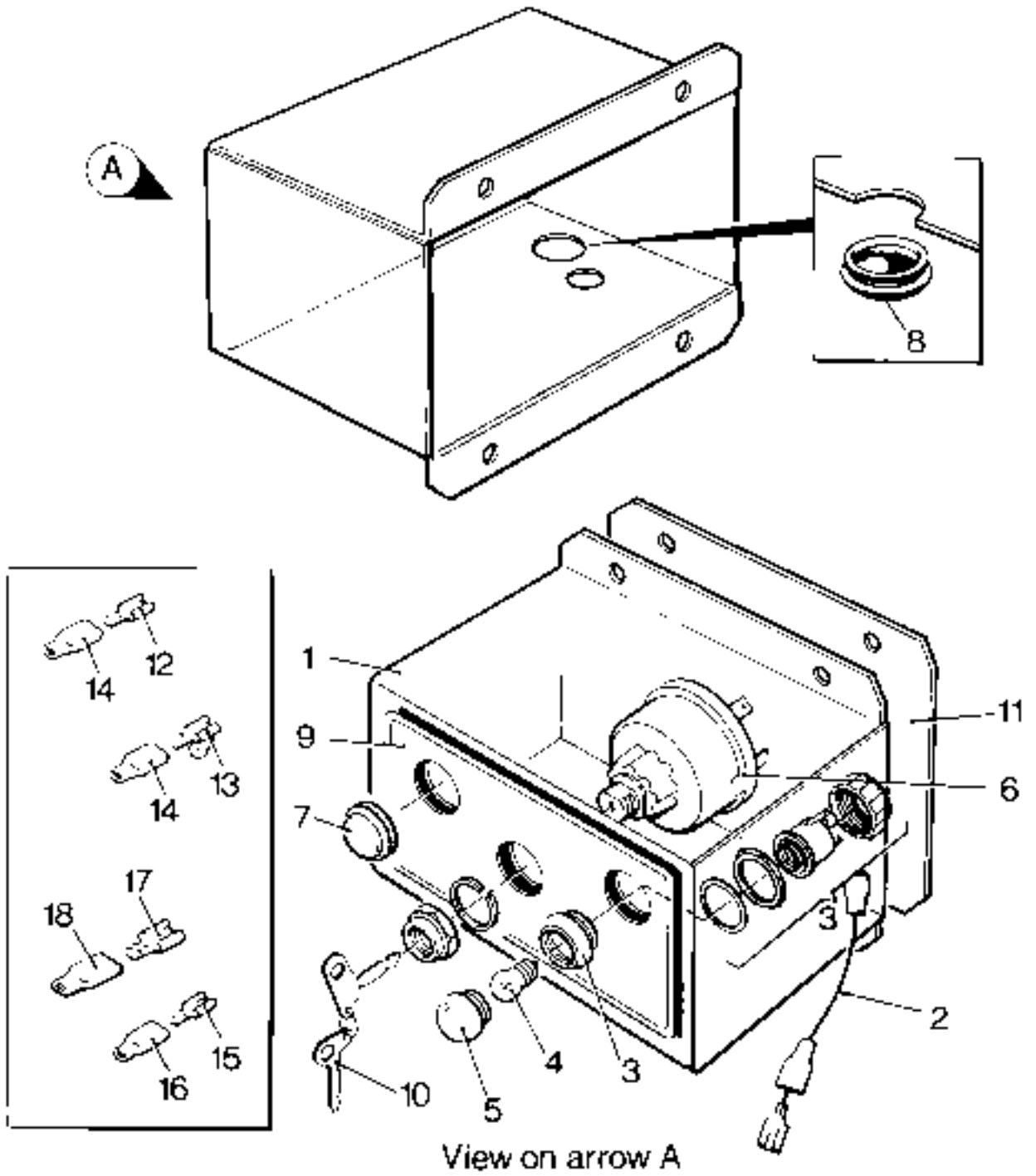

Electric Start Panel - 12V

For use with the Nicsa charging system and with provision
for two gauges in the panel

Illustration T188b

No.	Description	Part Number	TS/TR			Remarks
			1	2	3	
	Accessory Kit Code WA - TS/TR1	570-33782	1	-	-	
	Accessory Kit Code WA - TS/TR2,3	570-30553	-	1	1	
1	Panel	366-06937	1	1	1	
2	Cable	366-06433	1	1	1	
3	Lampholder	366-07228	1	1	1	
4	Lamp	064-09681/001	1	1	1	
5	Lens	064-20787/001	1	1	1	
6	Key Switch	366-06379	1	1	1	
7	Helvin Button	064-13033/008	1	1	1	
8	Blanking Plug	382-08080	1	1	1	
9	Label	027-06356	1	1	1	
10	Grommet	382-07342	2	2	2	
11	Cable Loom	366-08146	1	1	1	
12	Cable Clip	382-08256	2	2	2	
13	Setscrew - M6 x 12mm	272-00032	2	2	2	
14	Spring Washer	272-00070	2	2	2	
15	Nut	272-00002	1	1	1	
16	Mounting Bracket - TS/TR2,3	202-36442	-	1	1	
-	Mounting Bracket - TS/TR1	201-42660	1	-	-	
17	Flexible Mounting	064-07640	3	3	3	
18	Washer	064-06612/005	6	6	6	
19	Spring Washer	064-02582/002	6	6	6	
20	Nut	064-06610/003	6	6	6	
21	Bolt - M10 x 40mm	272-00116	2	2	2	
22	Spring Washer	272-00072	2	4	4	
23	Spacer	382-07208	2	2	2	
24	Key	366-08168	1	1	1	
-	Bolt - M10 x 45mm	272-00213	2	-	-	
-	Nut	272-00004	-	2	2	
	Wiring Diagram	742-00649				

Illustration T188b

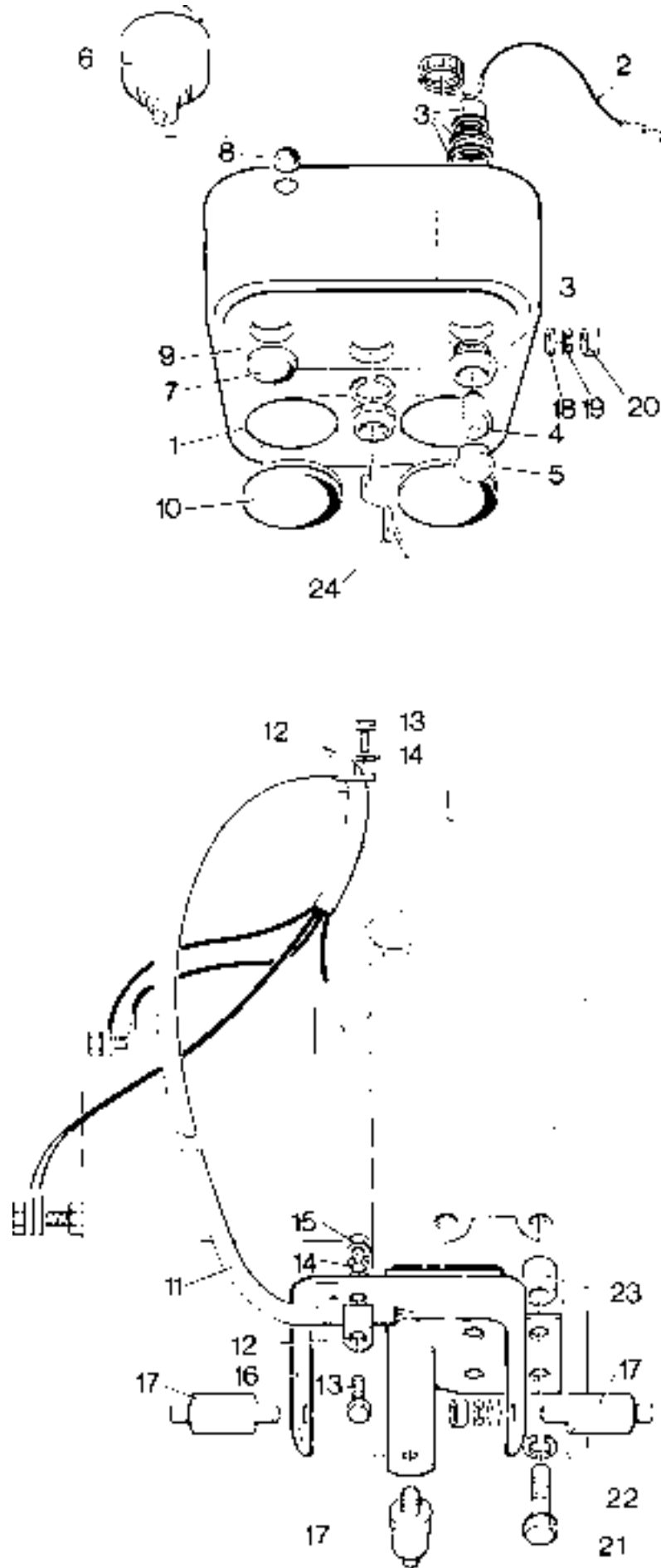

Key Switch and Charge Indicator

Illustration T190 No. Description	Part Number	TS/TR			Remarks
		1	2	3	
Accessory Kit Code WK	572-56250	1	1	1	
1 Key Switch	366-06379	1	1	1	
2 Connector	064-33068/002	1	1	1	
3 Cover	064-33991/002	1	1	1	
4 Connector	064-33068/004	1	1	1	
5 Cover	064-33991/004	1	1	1	

Charge Indicator Lamp

Illustration T190 No. Description	Part Number	TS/TR			Remarks
		1	2	3	
Accessory Kit Code WL	570-35450	1	1	1	
6 Lampholder	366-07228	1	1	1	
7 Lens	064-20787/001	1	1	1	
8 Lamp	064-09681/001	1	1	1	
9 Key	366-08168	1	1	1	
- Wiring Diagram	742-00648	1	1	1	
- Wiring Diagram	742-00796	1	1	1	

Note:

Suitable for builds 02, 07, 09, 11, 15, 61, 63, 66

Illustration T190

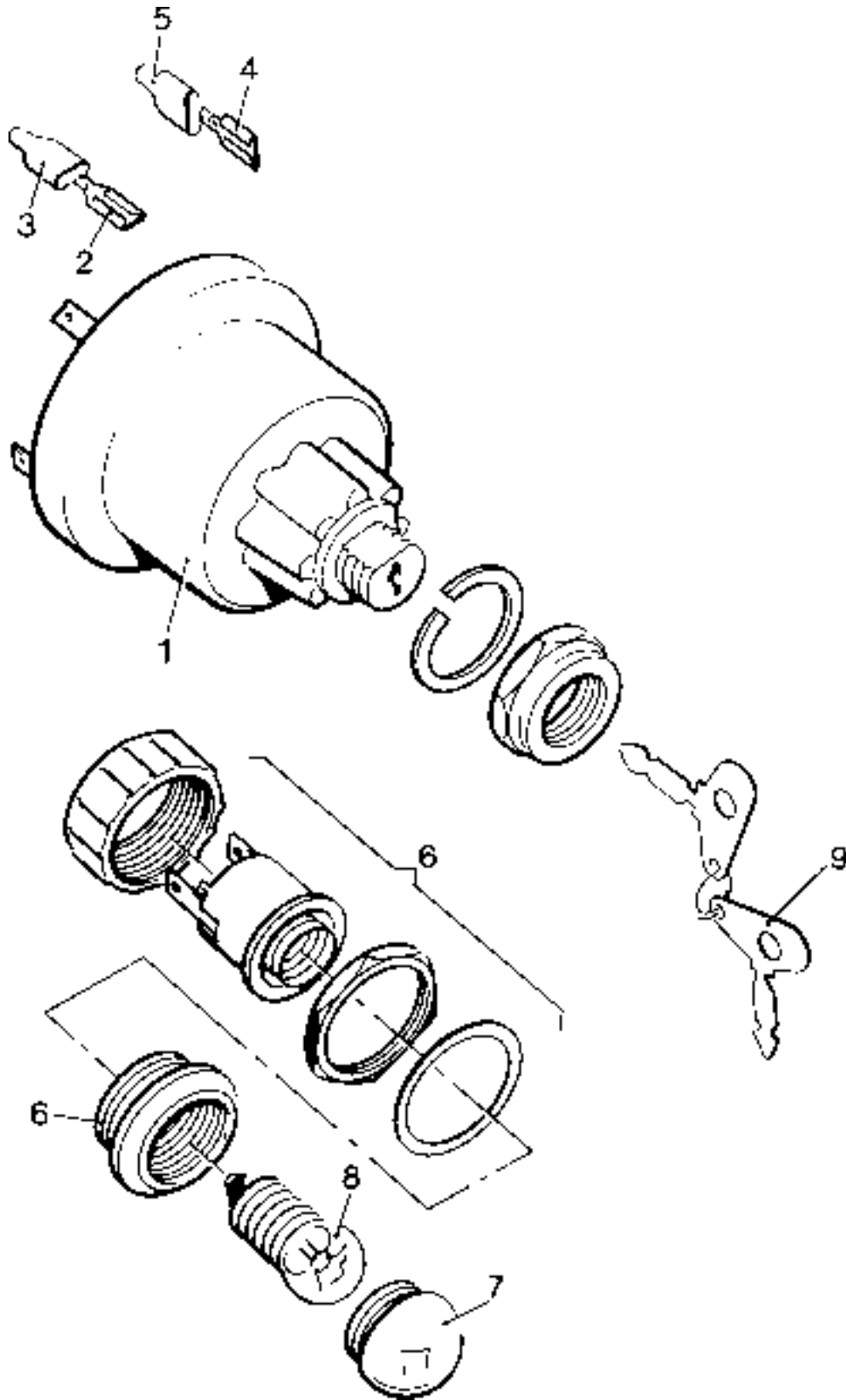

Key Switch Panel

Illustration T347

No. Description

Part Number

TS/TR

1 2 3 Remarks

No.	Description	Part Number	TS	TR	Remarks
	Accessory Kit Code WG - TS/TR1	570-34626	1	-	- Replaces 570-34625
	Accessory Kit Code WG - TS/TR2,3	570-34627	-	1	1 Replaces 570-34624
1	Cable Loom	366-08147	1	1	1
2	Panel	366-08260	1	1	1 Replaces 366-07596
3	Bracket - TS/TR1	366-07597	1	-	-
4	Spacer - TS/TR2,3	757-10970	-	2	2 Replaces 362729
-	Alternative Spacer - TS/TR2,3	027-07995	-	1	1 Replaces 366-08000
5	Nut - TS/TR1	272-00002	1	-	-
6	Spring Washer	272-00070	3	2	2
7	Setscrew - M6 x 20mm TS/TR1	272-00117	2	-	-
8	Bolt - M6 x 40mm TS/TR2,3	272-00036	-	2	2
9	Clip	382-08256	1	1	1
10	Key	366-08168	1	1	1
	Wiring Diagram	742-00647	1	1	1

Illustration T347

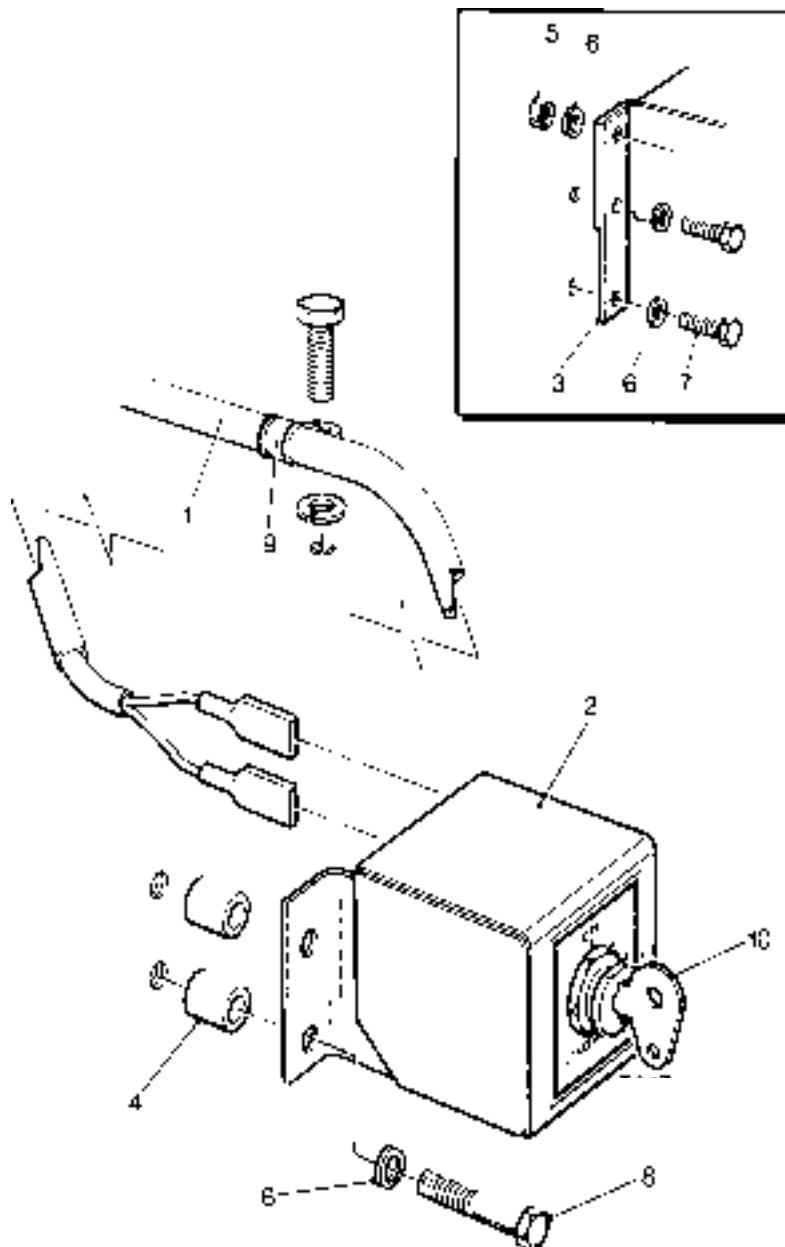

Key Switch and Hour Recorder Panel

Illustration T410
No. Description

TS/TR
Part Number 1 2 3 Remarks

	Accessory Kit Code WI - TS/TR1	570-36860	1	-	-	
	Accessory Kit Code WI - TS/TR2,3	570-36850	-	1	1	
1	Gauge Panel	570-36840	1	1	1	
2	Keyswitch	366-06379	1	1	1	
3	Hour Recorder	757-14501	1	1	1	
4	Spacer	027-07995	2	1	1	
5	Nut - TS/TR1	272-00002	1	-	-	
6	Spring Washer	272-00070	3	2	2	
7	Setscrew M6 x 20mm - TS/TR1	272-00117	1	-	-	
8	Bolt M6 x 30mm - TS/TR1	272-00035	1	-	-	
9	Bolt - M6 x 40mm	272-00036	1	2	2	
10	Spacer - TS/TR2,3	757-10970	-	2	2	
11	Loom Assembly	366-08147	1	1	1	
12	Cable Clip	382-08256	1	1	1	
13	Bracket - TS/TR1	366-07597	1	-	-	

Illustration T410

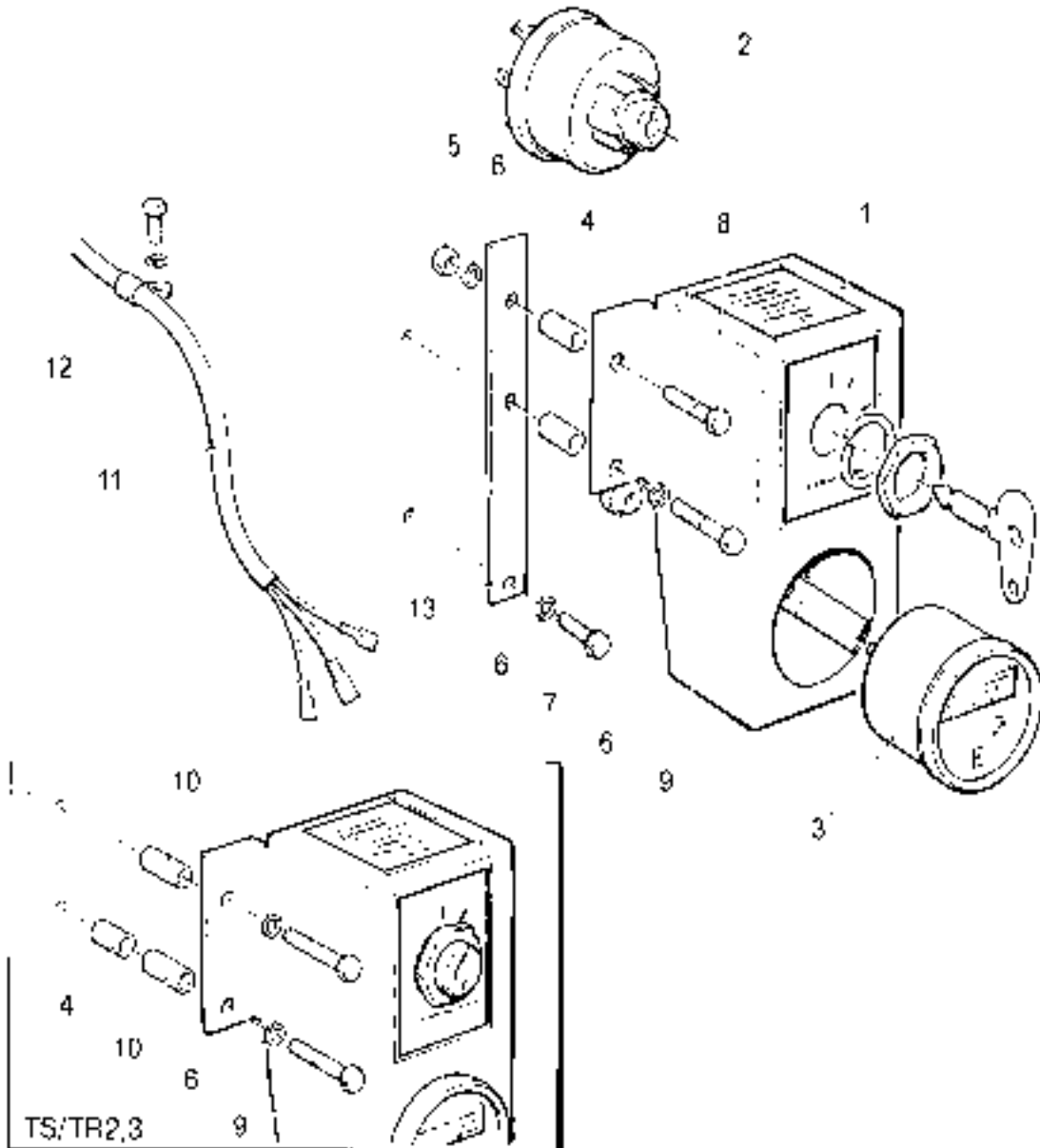

Cable Loom - Protective Switches - TS/TR2,3

Illustration T380 No. Description	Part Number	TS/TR			Remarks
		1	2	3	
Accessory Kit Code WC	570-30982	-	1	1	Comprises of Cable Loom 366-08049 and numbers 2-6
1 Cable Loom	366-08049	-	1	1	
- Cable Loom	366-08050	-	1	1	Head temperature and oil pressure switch, replaces 366-07206
- Cable Loom	366-08050	-	1	1	Air temperature and oil pressure switch, replaces 366-07205
2 Clip	382-08254	-	3	3	
3 Clip	382-08257	-	1	1	
4 Washer	027-00618	-	6	6	
5 Setscrew	272-00034	-	3	3	
6 Spring Washer	272-00070	-	3	3	
- Cable Tie	064-32790	-	3	3	

Battery Leads

Not Illustrated Description	Part Number	TS/TR			Remarks
		1	2	3	
Accessory Kit Code WO	570-13880	1	1	1	
Positive Lead	064-07172/001	1	1	1	
Negative Lead	064-07172/002	1	1	1	
Rubber Shroud	064-08391	2	2	2	

Illustration T380

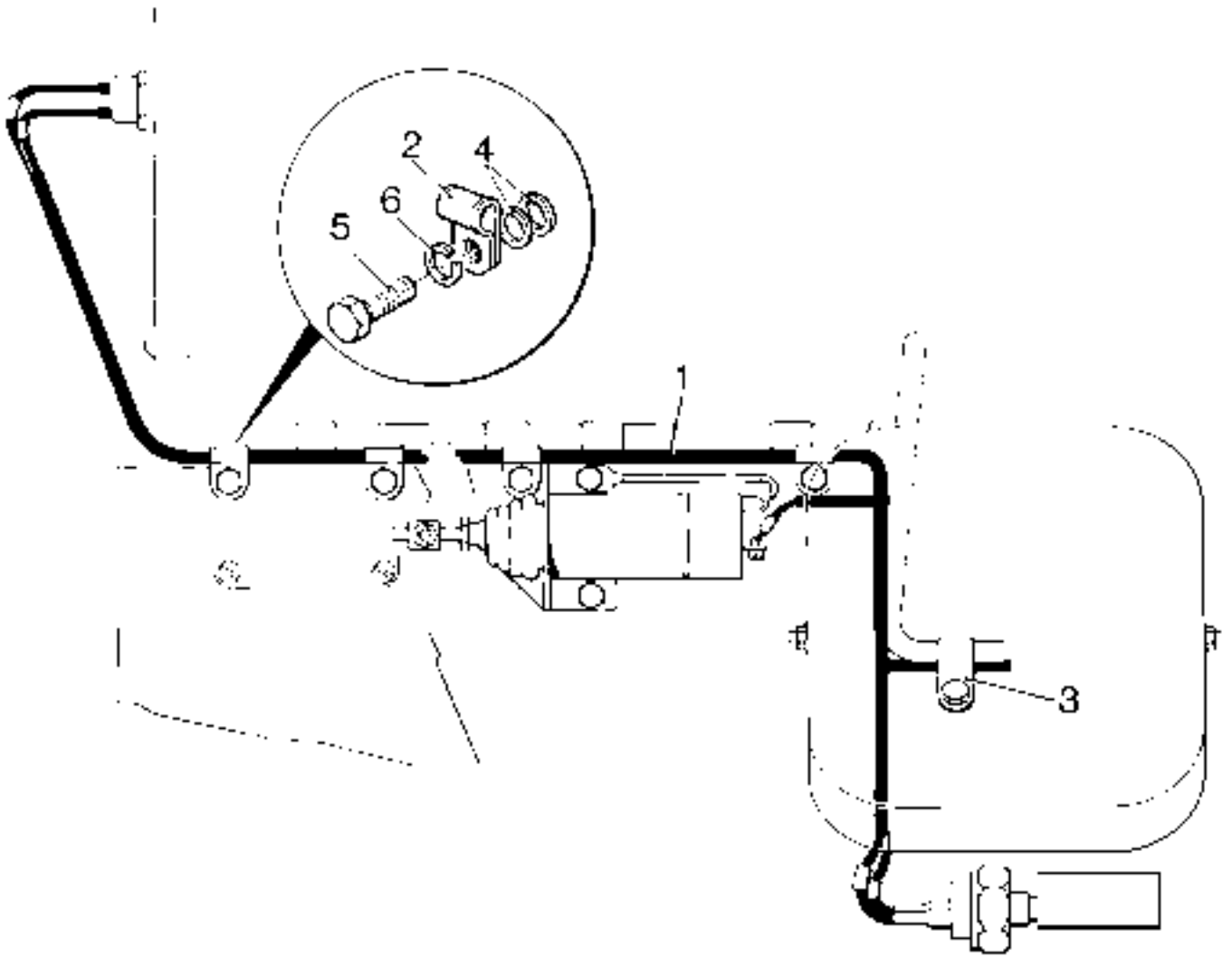

Lagging for Manifold Only (Not Build 16)

No.	Description	Part Number	TS/TR			Remarks
			1	2	3	
	Accessory Kit Code GQ - TS/TR1	570-37060	1	-	-	
	Accessory Kit Code GQ - TS/TR2	570-37100	-	1	-	
	Accessory Kit Code GQ - TS/TR3	570-37140	-	-	1	
-	Manifold Lagging - TS/TR1	366-08263	1	-	-	
-	Manifold Lagging - TS/TR2	366-08267	-	1	-	
-	Manifold Lagging - TS/TR3	366-08270	-	-	1	

Lagging for Manifold and Silencer Code NA

No.	Description	Part Number	TS/TR			Remarks
			1	2	3	
	Accessory Kit Code GR - TS/TR1	570-37070	1	-	-	
	Accessory Kit Code GR - TS/TR2	570-37110	-	1	-	
	Accessory Kit Code GR - TS/TR3	570-37150	-	-	1	
-	Manifold Lagging TS/TR1	366-08263	1	-	-	
-	Manifold Lagging TS/TR2	366-08267	-	1	-	
-	Manifold Lagging TS/TR3	366-08270	-	-	1	
-	Silencer Lagging TS/TR1	366-08264	1	-	-	
-	Silencer Lagging TS/TR2,3	366-08268	-	1	1	

Lagging for Manifold, Silencer Code NA, and Outlet Pipe Code NH

No.	Description	Part Number	TS/TR			Remarks
			1	2	3	
	Accessory Kit Code GW - TS/TR1	570-37080	1	-	-	
	Accessory Kit Code GW - TS/TR2	570-37120	-	1	-	
	Accessory Kit Code GW - TS/TR3	570-37160	-	-	1	
-	Manifold Lagging - TS/TR1	366-08263	1	-	-	
-	Manifold Lagging - TS/TR2	366-08267	-	1	-	
-	Manifold Lagging - TS/TR3	366-08270	-	-	1	
-	Silencer Lagging - TS/TR1	366-08264	1	-	-	
-	Silencer Lagging - TS/TR2,3	366-08268	-	1	-	
-	Outlet Pipe Lagging - TS/TR1,2,3	366-08265	1	-	-	

Lagging for Manifold and Silencer Code NL (Build 16 Only) - TS/TR1

No.	Description	Part Number	TS/TR			Remarks
			1	2	3	
	Accessory Kit Code GX	570-37090	1	-	-	
-	Manifold Lagging	366-08266	1	-	-	
-	Silencer Lagging	366-08275	1	-	-	

Lagging for Manifold and Manifold Flange Code NF - TS/TR2,3

No.	Description	Part Number	TS/TR			Remarks
			1	2	3	
	Accessory Kit Code GU - TS/TR2	570-37130	-	1	-	
	Accessory Kit Code GU - TS/TR3	570-37220	-	-	1	
-	Manifold Lagging - TS/TR2	366-08269	-	1	-	
-	Manifold Lagging - TS/TR3	366-08276	-	-	1	

Decompressor Lever Insulation

No.	Description	Part Number	TS/TR			Remarks
			1	2	3	
	Accessory Kit Code GH	570-72350	1	1	1	
-	Heat Insulating Tubing	027-10090	1	1	1	

Decarbonising Joint Sets - TS

No.	Description	Part Number	TS			Remarks
			1	2	3	
	Joint Set - TS1	657-32671	1	-	-	
	Joint Set - TS2	657-29501	-	1	-	
	Joint Set - TS3	657-29521	-	-	1	
	Cylinder Head Gasket	201-80210	1	2	3	
	Cylinder Head Shim	201-80220	3	6	9	
	Cylinder Head Shim	201-80221	1	2	3	
	Cylinder Barrel Joint	201-32430	1	2	3	
	Cylinder Head Cover Joint	201-30805	1	2	3	
	Cylinder Head Cover Washer	272-00364	4	8	12	
	Stub Shaft O Ring	201-31460	2	4	5	
	Inlet Valve Guide O Ring	201-81200	2	4	6	
	Inlet Valve Shield	201-37630	1	2	3	
	Exhaust Valve Shield	201-39520	-	2	3	
	Breather Tube Sealing Ring	601-35440	1	2	3	
	Push Rod Tube (Bottom)	201-30261	2	4	6	
	Push Rod Tube (Top)	201-42360	2	4	6	
	Injector Washer	351-40230	1	2	3	
	Manifold Joint	201-33420	1	4	6	
	Exhaust Joint	366-01287	1	1	1	
	Inlet Manifold Adaptor Joint (up to 35 4109 TS2)	201-31320	-	1	-	
	Inlet Manifold Adaptor Joint (up to 35 3463 TS3)	201-31320	-	-	1	
	Inlet Manifold Adaptor Joint (from 35 4110 TS2)	202-33231	-	1	-	
	Inlet Manifold Adaptor Joint (from 35 3464 TS3)	202-33231	-	-	1	
	Union Washer	352-29370	1	4	6	
	Union Washer	291-26090	2	-	-	
	Copper Washer	616-01608	3	7	10	

Overhaul Joint Sets - TS

No.	Description	Part Number	TS			Remarks
			1	2	3	
	Joint Set - TS1	657-32681	1	-	-	
	Joint Set - TS2	657-29511	-	1	-	
	Joint Set - TS3	657-29531	-	-	1	
	Cylinder Head Gasket	202-80210	1	2	3	
	Cylinder Head Shim	201-80220	3	6	9	
	Cylinder Head Shim	201-80221	1	2	3	
	Cylinder Barrel Joint	201-32430	1	2	3	
	Cylinder Head Cover Joint	201-30805	1	2	3	
	Cylinder Head Cover Washer	272-00364	8	16	24	
	Stub Shaft O Ring	201-31460	2	4	6	
	Valve Guide O Ring	201-81200	2	4	6	
	Inlet Valve Shield	201-37630	1	2	3	
	Exhaust Valve Shield	201-39520	-	2	3	
	Breather Tube Sealing Ring	601-35440	1	2	3	
	Push Rod Tube (Bottom)	201-30261	2	4	6	
	Push Rod Tube (Top)	201-42360	2	4	6	
	Injector Washer	351-40230	1	2	3	
	Manifold Joint	201-33420	1	2	6	
	Exhaust Joint	366-01287	1	1	1	
	Inlet Manifold Adaptor Joint (up to 35 4109 TS2)	201-31320	-	1	-	
	Inlet Manifold Adaptor Joint (up to 35 3463 TS3)	201-31320	-	-	1	
	Inlet Manifold Adaptor Joint (from 35 4110 TS2)	202-33231	-	1	-	
	Inlet Manifold Adaptor Joint (from 35 3464 TS3)	202-33231	-	-	1	
	Union Washer	352-29370	1	4	6	
	Union Washer	291-26090	6	-	-	
	Copper Washer	616-01608	6	19	25	
	Sump Joint	201-37751	1	-	-	
	Sump Joint	202-30541	-	1	-	
	Sump Joint	203-30542	-	-	1	
	Drain Plug Washer	013-21778	1	2	2	
	Main Bearing Housing O Ring	601-37420	1	1	1	
	Main Bearing Housing Shim	201-30943	2	2	2	
	Main Bearing Housing Shim	201-30944	2	2	2	
	Camshaft Shim	201-30680	1	1	1	
	Camshaft Shim	201-30681	1	1	1	
	Camshaft Shim	201-30682	1	1	1	
	Camshaft Shim	201-30683	1	1	1	
	Camshaft Shim	201-30684	1	1	1	
	Inspection Door Joint	201-39701	1	-	-	
	Inspection Door Joint	201-30612	-	2	3	
	Blanking Plate Joint	602-36271	1	1	1	
	End Cover Joint	201-33011	1	1	1	
	End Cover Joint (TS1 Build 7, TS2,3 Build 6,7)	201-33012	1	1	1	
	End Cover Washer	027-00082	7	7	7	
	End Cover Washer (TS1 Build 7, TS2,3 Build 6,7)	201-11890	2	2	2	
	Control Spindle O Ring	201-13120	2	2	2	
	Dipstick O Ring	266003	1	1	1	
	Fuel Pump O Ring	601-20691	1	2	3	
	Filler Cap Joint	303-00253	1	1	1	
	Air Duct Grommet	201-50950	1	2	3	
	Oil Plug O Ring	366-04010	-	1	1	
	Oil Pump O Ring	352-11911	-	1	1	
	Dowel Washer	600-00106	-	1	1	
	Union Washer	201-41640	-	2	2	
	Union Washer	354-26310	2	2	2	

Decarbonising Joint Sets - TR

Description	Part Number	TR			Remarks
		1	2	3	
Joint Set - TR1	657-33301	1	-	-	
Joint Set - TR2	657-33361	-	1	-	
Joint Set - TR3	657-33381	-	-	1	
Cylinder Head Gasket	201-33110	1	2	3	
Cylinder Head Shim	201-33100	3	6	9	
Cylinder Head Shim	201-33101	1	2	3	
Cylinder Barrel Joint	201-32430	1	2	3	
Cylinder Head Cover Joint	201-30805	1	2	3	
Cylinder Head Cover Washer	272-00364	4	-	-	
Stub Shaft O Ring	201-31460	2	4	6	
Inlet Valve Guide O Ring	201-81200	2	4	6	
Inlet Valve Shield	201-37630	1	2	3	
Exhaust Valve Shield	201-39520	-	2	3	
Breather Tube Sealing Ring	601-35440	1	2	3	
Push Rod Tube (Bottom)	201-30261	2	4	6	
Push Rod Tube (Top)	201-42360	2	4	6	
Injector Washer	351-40230	1	2	3	
Manifold Joint	201-33420	2	4	6	
Exhaust Joint	366-01287	1	1	1	
Inlet Manifold Adaptor Joint	202-33231	-	1	1	
Union Washer	352-29370	1	2	3	
Union Washer	291-26090	2	-	-	
Copper Washer	616-01608	4	8	12	

Overhaul Joint Sets - TR

Description	Part Number	TR			Remarks
		1	2	3	
Joint Set - TR1	657-33091	1	-	-	
Joint Set - TR2	657-33371	-	1	-	
Joint Set - TR3	657-33391	-	-	1	
Cylinder Head Gasket	201-33110	1	2	3	
Cylinder Head Shim	201-33100	3	6	9	
Cylinder Head Shim	201-33101	1	2	3	
Cylinder Barrel Joint	201-32430	1	2	3	
Cylinder Head Cover Joint	201-30805	1	2	3	
Cylinder Head Cover Washer	272-00364	8	-	-	
Stub Shaft O Ring	201-31460	2	4	6	
Valve Guide O Ring	201-81200	2	4	6	
Inlet Valve Shield	201-37630	1	2	3	
Exhaust Valve Shield	201-39520	-	2	3	
Breather Tube Sealing Ring	601-35440	1	2	3	
Push Rod Tube (Bottom)	201-30261	2	4	6	
Push Rod Tube (Top)	201-42360	2	4	6	
Injector Washer	351-40230	1	2	3	
Manifold Joint	201-33420	2	4	6	
Exhaust Joint	366-01287	1	1	1	
Inlet Manifold Adaptor Joint	202-33231	-	1	1	
Union Washer	352-29370	1	2	3	
Union Washer	291-26090	6	-	-	
Copper Washer	616-01608	9	19	23	
Sump Joint	201-37751	1	-	-	
Sump Joint	202-30541	-	1	-	
Sump Joint	203-30542	-	-	1	
Drain Plug Washer	013-21778	1	2	2	
Main Bearing Housing O Ring	601-37420	1	1	1	
Main Bearing Housing Shim	201-30943	2	2	2	
Main Bearing Housing Shim	201-30944	2	2	2	
Camshaft Shim	201-30680	1	1	1	
Camshaft Shim	201-30681	1	1	1	
Camshaft Shim	201-30682	1	1	1	
Camshaft Shim	201-30683	1	1	1	
Camshaft Shim	201-30684	1	1	1	
Inspection Door Joint	201-39701	1	-	-	
Inspection Door Joint	201-30612	-	2	3	
Blanking Plate Joint	602-36271	1	1	1	
End Cover Joint	201-33011	-	1	1	
End Cover Joint (Build 6,7 TR2)	201-33012	1	1	1	
End Cover Washer	027-00082	7	-	-	
End Cover Washer	201-11890	2	-	-	
Control Spindle O Ring	201-13120	2	2	2	
Dipstick O Ring	266003	1	1	1	
Fuel Pump O Ring	601-20691	1	2	3	
Filler Cap Joint	303-00253	1	1	1	
Air Duct Grommet	201-50950	1	2	3	
Oil Plug O Ring	366-04010	-	1	1	
Dowel Washer	600-00106	-	1	1	
Union Washer	201-41640	-	5	5	
Union Washer	354-26310	2	2	2	

Holding Down Bolts

Description	Part Number	TS/TR			Remarks
		1	2	3	
Accessory Kit Code QA	570-14070	1	1	1	
Bolt - 1/2" BSW x 18 1/2"	027-00584	4	4	4	
Nut - 1/2" BSW	027-00004	4	4	4	
Spring Washer - 1/2" diameter	027-00394	4	4	4	

Tool Kit

Description	Part Number	TS/TR			Remarks
		1	2	3	
Accessory Kit Code SJ	570-32490	1	1	1	
Tool Kit	366-07016	1	1	1	

Service Tools

Description of Tool	Part Number	Remarks
Valve Spring Compressor	393155	
Gear Puller Kit	393175	
Main bearing Tool	393235	Removal and replacement
Governor Rack Linkage Tool	393236	
Slide Hammer	317-50027	
Stub Shaft Adaptor	317-50028	Use with 317-50027
Valve Guide Base Tool	317-50033	Removal and replacement
Valve Guide Adaptor	317-50034	Use with 317-50033
Valve Guide Depth Stop	317-50039	Use with 317-50034
Valve Seat and Recess Cutting Tool	317-50042	
65mm Socket	317-50052	Use on flywheel bolt/nut
3/4" F - 1" M Adaptor	317-50053	Use with 317-50052
Flywheel Locking Tool	317-50057	
Crankshaft Extension Spanner	317-50060	Use to torque flywheel end
Flywheel End Crankshaft Oil Seal Installer	317-50065	
Flywheel End Crankshaft Oil Seal Remover	317-50074	
Valve Clearance Gauge	317-50094	
Injector Removal Adaptor	317-50096	Use with 317-50027
Gear End Camshaft Oil Seal Tool	317-50098	
Universal Puller Plate	317-50100	Use with 393171
Flywheel Mandrel	317-50102	
Fuel Injector Test Rig	317-50517	
Fuel Pump Timing Gauge	317-50518	



WARNING

Engine exhaust and some of its constituents are known to the State of California to cause cancer, birth defects, and other reproductive harm.

Lister-Petter Limited
Dursley
Gloucestershire
GL11 4HS
England

Tel: +44 (0)1453 544141
Fax: +44 (0)1453 546732
E-mail: sales@lister-petter.co.uk
<http://www.lister-petter.co.uk>

Lister-Petter Inc.
815 E. 56 Highway
Olathe
Kansas 66061
USA

Tel: +1 913 764-3512
Fax: +1 913 764-5493
E-mail: lpinfo@lister-petter.com
<http://www.lister-petter.com>

Lister-Petter France
1, Avenue de L'escouvrier
Zone d'Activites
95842 Sarcelles Cedex
France

Tel: +33 (0)1 39330420
Fax: +33 (0)1 34195760
E-mail: lister-petter-france.fr